TPMC150

4, 3, 2 or 1 Channel Synchro/Resolver-to-Digital Converter

Version 1.0

User Manual

June 2003

D76150800

TPMC150-10

4 Channel Synchro/Resolver-to-Digital Converter

TPMC150-11

3 Channel Synchro/Resolver-to-Digital Converter

TPMC150-12

2 Channel Synchro/Resolver-to-Digital Converter

TPMC150-13

1 Channel Synchro/Resolver-to-Digital Converter

Signal Conditioning Adapter

TPMC150-A1-xx

Resolver interface

TPMC150-A2-xx

Resolver interface with reference oscillator

TPMC150-A3-xx

High precision synchro/resolver interface

TPMC150-A4-xx

High precision synchro/resolver interface with reference oscillator

This document contains information, which is proprietary to TEWS TECHNOLOGIES GmbH. Any reproduction without written permission is forbidden.

TEWS TECHNOLOGIES GmbH has made any effort to ensure that this manual is accurate and complete. However TEWS TECHNOLOGIES GmbH reserves the right to change the product described in this document at any time without notice.

TEWS TECHNOLOGIES GmbH is not liable for any damage arising out of the application or use of the device described herein.

Style Conventions

Hexadecimal characters are specified with prefix 0x, i.e. 0x029E (that means hexadecimal value 029E).

For signals on hardware products, an 'Active Low' is represented by the signal name with # following, i.e. IP_RESET#.

Access terms are described as:

- W Write Only
- R Read Only
- R/W Read/Write
- R/C Read/Clear
- R/S Read/Set

©2003 by TEWS TECHNOLOGIES GmbH

Issue	Description	Date
-	Preliminary Issue	February 2003
1.0	First Issue	June 2003

Table of Contents

1	PRODUCT DESCRIPTION	6
2	TECHNICAL SPECIFICATION	8
	2.1 Tracking Rate Characteristics	9
	2.2 Velocity Output Characteristics	9
	2.3 Digital Input Characteristics	10
3	TPMC150 LOCAL SPACE ADDRESSING	11
	3.1 PCI9030 Local Space Configuration	11
	3.2 Register Address Space.....	12
	3.2.1 Global Control/Status Register	13
	3.2.2 Interrupt Control/Status Register	14
	3.2.3 Digital Input Register.....	15
	3.2.4 Channel Control Register.....	15
	3.2.5 Channel Data Register.....	17
	3.2.6 Channel Status Register	18
	3.2.7 Encoder Counter Preload/Data Register	19
4	PCI9030 TARGET CHIP	20
	4.1 PCI Configuration Registers (PCR).....	20
	4.1.1 PCI9030 Header	20
	4.1.2 PCI Base Address Initialization	21
	4.2 Local Configuration Register (LCR).....	22
	4.3 Configuration EEPROM.....	23
	4.4 Local Software Reset.....	24
5	CONFIGURATION HINTS	25
	5.1 Software Reset (Controller and LRESET#).....	25
	5.2 Big / Little Endian.....	25
	5.3 Local read/write.....	26
	5.4 Changing Resolution on the Fly.....	26
	5.5 Operating Modes.....	27
	5.5.1 Converter Operating Modes.....	27
	5.5.2 Encoder Operating Modes	28
	5.6 Binary Angle Relationships	33
6	SIGNAL CONDITIONING ADAPTER	34
	6.1 Signal Conditioning Adapter Characteristics	35
	6.2 Required Synchro/Resolver specifications.....	35
	6.3 Connector Pin Assignments.....	36
	6.3.1 20 Pin Connector - Front-I/O Side	36
	6.3.2 20 Pin Connector - Converter Side	36
7	INSTALLATION HINTS	37
	7.1 Connection Examples.....	37
	7.1.1 Resolver with external reference	38
	7.1.2 Resolver with internal reference	38
	7.1.3 Single ended resolver with external reference.....	38
	7.1.4 Synchro with external reference	39
8	PIN ASSIGNMENT – I/O CONNECTOR	40

TABLE OF FIGURES

FIGURE 1-1 : SIGNAL CONDITIONING ADAPTER TPMC150-A1/A3	6
FIGURE 1-2 : SIGNAL CONDITIONING ADAPTER TPMC150-A2/A4 WITH REFERENCE OSCILLATOR	6
FIGURE 1-3 : BLOCK DIAGRAM TPMC150-10	7
FIGURE 2-1 : TECHNICAL SPECIFICATION TPMC150	8
FIGURE 2-2 : TRACKING RATE CHARACTERISTICS	9
FIGURE 2-3 : VELOCITY OUTPUT CHARACTERISTICS	9
FIGURE 2-4 : VELOCITY RIPPLE FILTER.....	10
FIGURE 2-5 : DIGITAL INPUT CHARACTERISTICS.....	10
FIGURE 2-6 : DIGITAL INPUT WIRING	10
FIGURE 3-1 : PCI9030 LOCAL SPACE CONFIGURATION	11
FIGURE 3-2 : REGISTER ADDRESS SPACE.....	12
FIGURE 3-3 : GLOBAL CONTROL/STATUS REGISTER.....	13
FIGURE 3-4 : INTERRUPT CONTROL/STATUS REGISTER.....	14
FIGURE 3-5 : INPUT INTERRUPT CONFIGURATION	14
FIGURE 3-6 : DIGITAL INPUT REGISTER	15
FIGURE 3-7 : CHANNEL CONTROL REGISTER	16
FIGURE 3-8 : CHANNEL DATA REGISTER	17
FIGURE 3-9 : LSB POSITION.....	17
FIGURE 3-10: CHANNEL STATUS REGISTER.....	18
FIGURE 3-11: ENCODER COUNTER PRELOAD/DATA REGISTER	19
FIGURE 4-1 : PCI9030 HEADER.....	20
FIGURE 4-2 : PCI9030 PLD BASE ADDRESS USAGE	21
FIGURE 4-3 : PCI9030 LOCAL CONFIGURATION REGISTER	22
FIGURE 4-4 : CONFIGURATION EEPROM TPMC150-XX	23
FIGURE 5-1 : LOCAL BUS LITTLE/BIG ENDIAN.....	25
FIGURE 5-2 : INCREMENTAL ENCODER RESOLUTION	28
FIGURE 5-3 : ENCODER SIGNAL ANALYSIS MODES	29
FIGURE 5-4 : ENCODER SIGNAL INTERPRETATION	29
FIGURE 5-5 : ENCODER COUNT PER REVOLUTION.....	29
FIGURE 5-6 : ENCODER REFERENCE MODES	30
FIGURE 5-7 : ENCODER PRELOAD EXAMPLE	31
FIGURE 5-8 : BINARY ANGLE RELATIONSHIPS	33
FIGURE 6-1 : SIGNAL CONDITIONING ADAPTER TPMC150-A1/A3	34
FIGURE 6-2 : SIGNAL CONDITIONING ADAPTER TPMC150-A2/A4 WITH REFERENCE OSCILLATOR	34
FIGURE 6-3 : TPMC150 ADAPTER VARIANTS	34
FIGURE 6-4 : TECHNICAL SPECIFICATION TPMC150-A1 - A4.....	35
FIGURE 6-5 : PIN ASSIGNMENT - 20 PIN CONNECTOR FRONT I/O SIDE	36
FIGURE 6-6 : PIN ASSIGNMENT - 20 PIN CONNECTOR CONVERTER SIDE	36

FIGURE 7-1 : TPMC150 ADAPTER PLACEMENT	37
FIGURE 7-2 : RESOLVER WITH EXTERNAL REFERENCE	38
FIGURE 7-3 : RESOLVER WITH INTERNAL REFERENCE.....	38
FIGURE 7-4 : SINGLE ENDED RESOLVER WITH EXTERNAL REFERENCE	38
FIGURE 7-5 : SYNCHRO WITH EXTERNAL REFERENCE.....	39
FIGURE 8-1 : PIN ASSIGNMENT I/O CONNECTOR.....	40

1 Product Description

The TPMC150 is a standard single-width 32 bit PMC module providing four (TPMC150-10), three (TPMC150-11), two (TPMC150-12) or one channel (TPMC150-13) of a Tracking Synchro/Resolver-To-Digital Converter (RDC) with a converter accuracy of 2 arcmin + 1LSB.

The TPMC150 is designed for use in high performance commercial, industrial and military systems. It can be used for many applications like motor control, robot axis control, process control, radar antenna position information, and CNC machine tooling.

Each of the up to four RDC channels on the TPMC150 utilizes DDC's versatile state-of-the-art Tracking Synchro/Resolver-To-Digital Converter RDC19230 with programmable resolution. Resolution programming allows selection of 10-, 12-, 14 or 16 bit conversion. This combines the high tracking rate of a 10 bit converter with the precision of a 16 bit converter. The RDC19230 provides incremental encoder emulation. Encoder phase signals A, B and Index I are fed to an on board 32 bit up-/down encoder counter with preload and output register. Additionally the synthesized encoder signals are available for external use via RS485/422 output drivers. The RDC19230 provides a 4V velocity output with a linearity of 0.75%, which can be used to replace a tachometer. A 24V isolated digital input per channel can be used as general purpose input or as reference input.

A 'Simultaneous Read' function allows latching of the actual values of the selected converters at the same time.

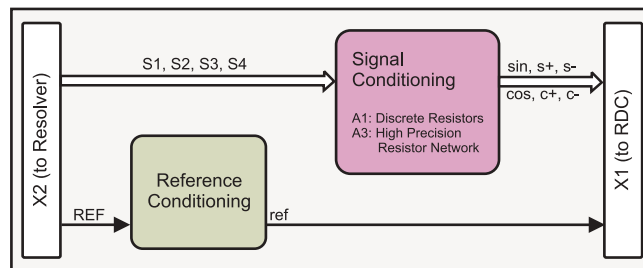

Figure 1-1 : Signal Conditioning Adapter TPMC150-A1/A3

Signal Conditioning Adapters (TPMC150-Ay-xx) are required for each synchro/resolver channel to adapt the signal levels of the synchro/resolver to the RDC19230 and to configure the optional reference oscillator input/output. The Signal Conditioning Adapters will be built individually to customer specification of the synchro or resolver specifications. The Signal Conditioning Adapters are factory installed on the TPMC150.

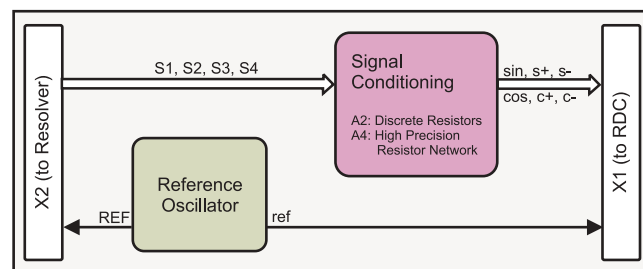

Figure 1-2 : Signal Conditioning Adapter TPMC150-A2/A4 with reference oscillator

Four types of Signal Conditioning Adapters are available to adapt the signal levels of the synchro/resolver to the RDC19230: The TPMC150-A1-xx and the TPMC150-A2-xx use high precision, low TK discrete resistors. These Adapters are mainly used for resolver applications. The TPMC150-A3-xx and the TPMC150-A4-xx use a high precision resistor network with matched resistors. These adapters are mainly used for synchro applications or resolver applications which require highest accuracy. Additionally the TPMC150-A2-xx and the TPMC150-A4-xx offer an on board reference oscillator with factory selectable frequencies in the range of 2 kHz to 10 kHz.

The on board encoder counter for each channel is a 32 bit up-/down counter with preload and output register. The encoder counter is fed with the emulated A, B and Index signals from the RDC19230. The counters are programmable for single, double and quad analysis of the incremental encoder signals. The counter can be manually or automatically loaded with the value of the preload register, depending on mode. An 'Auto Reference Mode' provides the possibility of automatic preload of the encoder counter during normal operation, whenever the motion system passes the reference position. A 'Simultaneous Read' function allows latching of the actual values of the selected encoder counters. These values can then be read successively without interfering with normal counter function.

The TPMC150 offers one digital 24V input per channel which is galvanically isolated by optocouplers. A high performance input circuit ensures a defined switching point and polarization protection against confusing the pole. The inputs are electronically debounced. Each of the four digital 24V inputs can generate an interrupt, triggered on rising or falling edge. Depending on the selected mode the input can be used as general purpose input or as reference input.

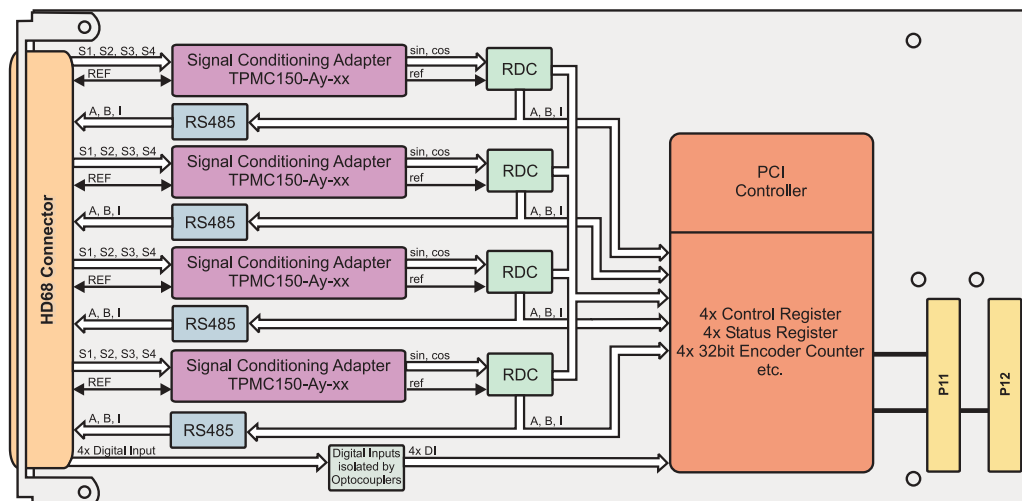

Figure 1-3 : Block Diagram TPMC150-10

2 Technical Specification

Mechanical Interface	PCI Mezzanine Card (PMC) Interface Single Size	
Electrical Interface	PCI Rev. 2.2 compliant 33MHz / 32 bit PCI 3.3V and 5V PCI Signaling Voltage	
On Board Devices		
PCI Target Chip	PCI9030 (PLX Technology)	
Converter Chip	RDC 19230	
Converter Resolution	Programmable 10,12,14 or 16 bits	
Converter Accuracy	2 arcmin + 1 LSB	
Input Signal Conditioning	Signal Conditioning Adapter TPMC150-A1 – TPMC150-A4	
Additional Output	Velocity output Incremental encoder emulation, available as RS422/485 outputs	
Motion Feedback	32 bit up/down encoder counter with preload and output register per channel	
Digital Input	1 digital 24V input per channel	
I/O Interface		
I/O Connector	HD68 SCSI-3 type female connector (no PMC P14 I/O)	
Physical Data		
Power Requirements	260 mA typical @ +3.3V DC 85 mA typical @ +5.0V DC 75 mA typical @ -12V DC	
Temperature Range	Operating	-40°C to +85°C
	Storage	-40°C to +125°C
MTBF	TPMC150-10: 240 000 h TPMC150-11: 286 000 h TPMC150-12: 354 000 h TPMC150-13: 464 000 h	
Humidity	5 – 95 % non-condensing	
Weight	71 g	

Figure 2-1 : Technical Specification TPMC150

2.1 Tracking Rate Characteristics

Tracking Rate, bandwidth and velocity scaling is dependent on the resolution of the RDC.

rps = Revolutions per second

Resolution	10	12	14	16
Tracking rate (rps)	1022	255	64	16
Bandwidth (Hz)	1024		270	
Carrier frequency (kHz)	4 - 10	4 - 10	1 - 7	1 - 5
Scale factor (V/rps)	0.0039	0.0157	0.0625	0.25

Figure 2-2 : Tracking Rate Characteristics

2.2 Velocity Output Characteristics

Parameter	Unit	Typical	Min/Max
Polarity		Positive for increasing angle	
Voltage range (full scale)	V	±4	
Scale factor error	%	10	20
Scale factor TC	PPM/C	100	200
Reversal error	%	0.75	1.3
Linearity	%	0.25	0.5
Zero Offset	mV	5	10
Zero Offset TC	µV/C	15	30
Load	kΩ		8

Figure 2-3 : Velocity Output Characteristics

Applying loads on the velocity output may affect converter accuracy. To use the velocity output line to monitor speeds, you must add a buffer to the line.

The velocity output is a DC-signal with an AC-ripple. The main components of the ripple are the carrier frequency and double the carrier frequency. The ripple can be filtered behind the buffer. Set the RC to cut off below the carrier frequency.

Neither the buffer nor the velocity ripple filter is included on the TPMC150.

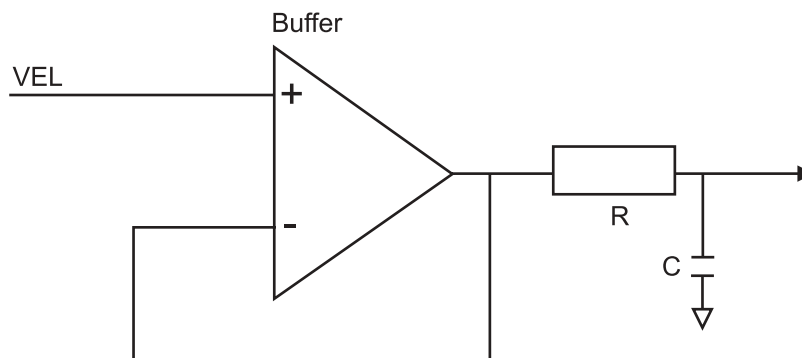

Figure 2-4 : Velocity Ripple Filter

2.3 Digital Input Characteristics

The TPMC150 offers one digital 24V input per channel which is galvanically isolated by optocouplers. A high performance input circuit ensures a defined switching point and polarization protection against confusing the pole. The inputs are electronically debounced. Each of the four digital 24V inputs can generate an interrupt, triggered on rising or falling edge. Depending on the selected reference mode the input can be used as general purpose input or as reference input.

Parameter	Unit	Typical
Input isolation		Optocoupler as galvanic isolation
Input voltage	V	24
Input current	mA	4.2 (at 24V input voltage)
Switching level	V	12 (min. 7.5, max. 14)

Figure 2-5 : Digital Input Characteristics

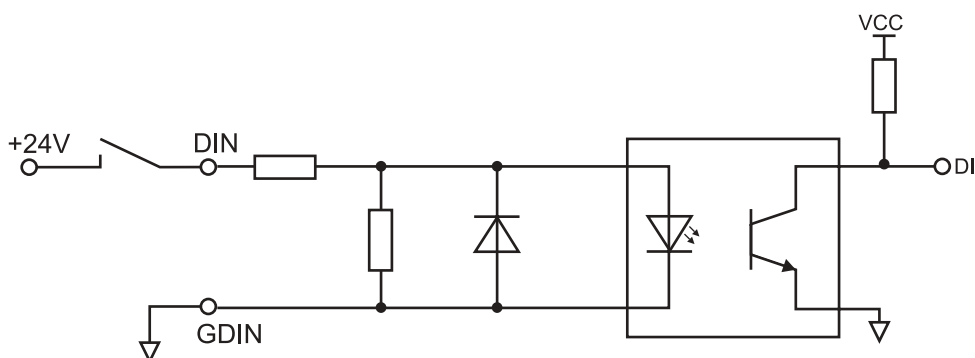

Figure 2-6 : Digital Input Wiring

3 TPMC150 Local Space Addressing

3.1 PCI9030 Local Space Configuration

The local on board addressable regions are accessed from the PCI side by using the PCI9030 local spaces.

PCI9030 Local Space	PCI9030 PCI Base Address (Offset in PCI Configuration Space)	PCI Space Mapping	Size (Byte)	Port Width (Bit)	Endian Mode	Description
0	2 (0x18)	MEM	128	32	BIG	Register Address Space
1	3 (0x1C)	-	-	-	-	Not Used
2	4 (0x20)	-	-	-	-	Not Used
3	5 (0x24)	-	-	-	-	Not Used

Figure 3-1 : PCI9030 Local Space Configuration

3.2 Register Address Space

PCI Base Address: PCI9030 PCI Base Address 2 (Offset 0x18 in PCI Configuration Space).

Offset to PCI Base Address 2	Register Name	Size (Bit)
0x00	Global Control/Status Register	32
0x04	Interrupt Control/Status Register	32
0x08	Digital Input Register	32
0x0C	Channel Control Register 1	32
0x10	Channel Control Register 2	32
0x14	Channel Control Register 3	32
0x18	Channel Control Register 4	32
0x1C	Channel Data Register 1	32
0x20	Channel Data Register 2	32
0x24	Channel Data Register 3	32
0x28	Channel Data Register 4	32
0x2C	Channel Status Register 1	32
0x30	Channel Status Register 2	32
0x34	Channel Status Register 3	32
0x38	Channel Status Register 4	32
0x3C	Encoder Counter Preload/Data Register 1	32
0x40	Encoder Counter Preload/Data Register 2	32
0x44	Encoder Counter Preload/Data Register 3	32
0x48	Encoder Counter Preload/Data Register 4	32
0x4C ... 0x80	Reserved	-

Figure 3-2 : Register Address Space

If in the following register descriptions the equivalent bits of all channels are combined into a bit field, the bit field refers to the channels in ascending order. For example the LSB of the bit field refers to Channel 1 and the MSB to Channel 4.

3.2.1 Global Control/Status Register

Bit	Symbol	Description	Access	Reset
17-31		Reserved (Undefined for reads. Write as '0'.)	-	X
16	CTRL_CON_STA	Multiple Converter Read Status 1: Multiple Converter Read in progress	R	0
12-15	CTRL_CON_SEL	Multiple Converter Read Channel Select Writing a '1' to a bit select the corresponding channel for Multiple Encoder Read.	R/W	0000
11	CTRL_CON_RD	Multiple Converter Read 0: Disabled 1: Enabled See chapter 'Multiple Converter Read' for details.	R/W	0
10	CTRL_ENC_STA	Multiple Encoder Read Status 1: Multiple Encoder Read in progress	R	0
6-9	CTRL_ENC_SEL	Multiple Encoder Read Channel Select Writing a '1' to a bit select the corresponding channel for Multiple Encoder Read.	R/W	0000
5	CTRL_ENC_RD	Multiple Encoder Read 0: Disabled 1: Enabled See chapter 'Multiple Encoder Read' for details.	R/W	0
4	CTRL_IRQ	General IRQ Enable 0: globally disables interrupts 1: globally enables interrupts for the digital 24V inputs.	R/W	0
0-3	CTRL_PRE	Manual Encoder Counter Preload Writing a '1' issues a preload of the corresponding encoder counter with the value of the Encoder Counter Preload Register. This preload method is only possible in the 'None Reference Mode'. After the preload access is executed, these bits are cleared automatically and signal a successful preload. Before using this preload method, the corresponding Encoder Counter Preload Register must be loaded with valid data.	R/W	0000

Figure 3-3 : Global Control/Status Register

The digital 24V inputs generate interrupts at pin INTA# of the PMC bus. Additional to this Global Interrupt Enable the Interrupt INTA# must be enabled in the Interrupt Control Register (INTCSR; 0x4C) of the PCI Controller PCI9030. Default after power on and reset: INTA# is enabled.

3.2.2 Interrupt Control/Status Register

Bit	Symbol	Description	Access	Reset
12-31		Reserved (Undefined for reads. Write as '0'.)	-	X
8-11	IRQ_CTRL	Digital Input Interrupt Control 0: interrupt on falling edge 1: interrupt on rising edge	R/W	0000
4-7	IRQ_STA	Digital Input Interrupt Status 0: no interrupt request is pending 1: an interrupt request is pending A pending interrupt request for a specific digital 24V input is cleared by writing a '1' to the according status bit.	R/W	0000
0-3	IRQ_EN	Digital Input Interrupt Enable To enable the interrupt for a digital input, set the corresponding bit to '1'.	R/W	0000

Figure 3-4 : Interrupt Control/Status Register

The following table shows a short overview about enabling interrupts and the active trigger edge.

Digital 24V input	Bit	Interrupt		Bit	Active edge	
		disable	enable		falling	rising
DIN1	0	'0'	'1'	8	'0'	'1'
DIN2	1	'0'	'1'	9	'0'	'1'
DIN3	2	'0'	'1'	10	'0'	'1'
DIN4	3	'0'	'1'	11	'0'	'1'

Figure 3-5 : Input Interrupt configuration

3.2.3 Digital Input Register

Bit	Symbol	Description	Access	Reset
4-31		Reserved (Undefined for reads. Write as '0'.)	-	X
0-3	DIN	Digital Input State Reflects the actual state of the digital 24V inputs. This register is always active and reflects the state of the digital 24V inputs at all times.	R	0000

Figure 3-6 : Digital Input Register

In the 'None Reference Mode' and 'Index Mode' the digital 24V inputs can be used as general purpose inputs.

In the 'Reference Mode' and 'Auto Reference Mode' the digital 24V inputs are used as reference inputs

3.2.4 Channel Control Register

Bit	Symbol	Description	Access	Reset										
10-31		Reserved (Undefined for reads. Write as '0'.)	-	X										
9	CH_EMU_OUT	Incremental Encoder Emulation Output 0: Disabled 1: Output of the Encoder Emulation via the RS485/422 drivers enabled See chapter 'Incremental Encoder Emulation Output' for details.	R/W	0										
8	CH_EMU_EN	Incremental Encoder Emulation 0: Disabled 1: Enabled; this bit activates the Incremental Encoder Emulation. When set to '1', the current converter resolution is latched and used for the Incremental Encoder Emulation. This bit also enables the Encoder Counter.	R/W	0										
6-7	CH_REF	Encoder Reference Mode <table border="1" data-bbox="671 1303 1179 1503"> <thead> <tr> <th>Value</th> <th>Reference Mode</th> </tr> </thead> <tbody> <tr> <td>0 0</td> <td>None Reference Mode</td> </tr> <tr> <td>0 1</td> <td>Reference Mode</td> </tr> <tr> <td>1 0</td> <td>Auto Reference Mode</td> </tr> <tr> <td>1 1</td> <td>Index Mode</td> </tr> </tbody> </table> See chapter 'Reference Mode' for details.	Value	Reference Mode	0 0	None Reference Mode	0 1	Reference Mode	1 0	Auto Reference Mode	1 1	Index Mode	R/W	00
Value	Reference Mode													
0 0	None Reference Mode													
0 1	Reference Mode													
1 0	Auto Reference Mode													
1 1	Index Mode													
4-5	CH_ESAM	Encoder Signal Analysis Mode <table border="1" data-bbox="671 1581 1179 1780"> <thead> <tr> <th>Value</th> <th>Analysis Mode</th> </tr> </thead> <tbody> <tr> <td>0 0</td> <td>disable Counter</td> </tr> <tr> <td>0 1</td> <td>1x – single</td> </tr> <tr> <td>1 0</td> <td>2x – double</td> </tr> <tr> <td>1 1</td> <td>4x – quad</td> </tr> </tbody> </table> See chapter 'Encoder Signal Analysis Mode' for details.	Value	Analysis Mode	0 0	disable Counter	0 1	1x – single	1 0	2x – double	1 1	4x – quad	R/W	00
Value	Analysis Mode													
0 0	disable Counter													
0 1	1x – single													
1 0	2x – double													
1 1	4x – quad													

Bit	Symbol	Description	Access	Reset										
3	CH_SYN_CON	Synchronous Conversion 0: Disabled 1: Enabled (only Channel 1 & 3) For channel 2 and 4 a set on CH_SYN_CON is ignored and a read access returns a '0'. See chapter 'Operating with Synchronous Conversion' for details.	R/W	0										
2	CH_SYN_LAT	Synchronous Status Latch 0: Disabled 1: Enabled See chapter 'Operating with Synchronous Status Latch' for details.	R/W	0										
0-1	CH_RES	Converter Resolution Sets the converter resolution. Available values are: <table border="1" data-bbox="769 683 1082 880"> <thead> <tr> <th>Value</th> <th>Resolution</th> </tr> </thead> <tbody> <tr> <td>0 0</td> <td>10 bit</td> </tr> <tr> <td>0 1</td> <td>12 bit</td> </tr> <tr> <td>1 0</td> <td>14 bit</td> </tr> <tr> <td>1 1</td> <td>16 bit</td> </tr> </tbody> </table>	Value	Resolution	0 0	10 bit	0 1	12 bit	1 0	14 bit	1 1	16 bit	R/W	00
Value	Resolution													
0 0	10 bit													
0 1	12 bit													
1 0	14 bit													
1 1	16 bit													

Figure 3-7 : Channel Control Register

The converter resolution can be changed after the Incremental Encoder Emulation resolution is set, but it must not be less than the resolution of the Incremental Encoder Emulation. If the converter resolution is less than the Incremental Encoder Emulation resolution, there will be no Encoder Emulation output!

3.2.5 Channel Data Register

The Channel Data Register contains the 16 bit wide converted data value of the synchro or resolver. When the resolution is set to less than 16 bits, all unused bits are read as '0'. The conversion result is always MSB aligned (i.e. aligned to bit 15). The resolution is controlled by the Channel Control Register.

Bit	Symbol	Description	Access	Reset
16-31		Reserved (Reads as '0')	-	X
0-15	CH_DATA	Converter Data	R	0

Figure 3-8 : Channel Data Register

The position of the LSB depends on the resolution:

Resolution	D31-16	D15	D14...7	D6	D5	D4	D3	D2	D1	D0
10	0	MSB	X	LSB	0	0	0	0	0	0
12	0	MSB	X	X	X	LSB	0	0	0	0
14	0	MSB	X	X	X	X	X	LSB	0	0
16	0	MSB	X	X	X	X	X	X	X	LSB

Figure 3-9 : LSB Position

3.2.6 Channel Status Register

Bit	Symbol	Description	Access	Reset
3-31		Reserved (Undefined for reads. Write as '0'.)	-	X
2	CH_STA_DIR	Direction of Motion 0: down (clockwise, angle decreasing) 1: up (counter clockwise, angle increasing) On a static signal, CH_STA_DIR indicates the last direction of motion.	R	0
1	CH_STA_AM	Adapter mounting 0: No adapter mounted 1: Adapter mounted	R	0
0	CH_STA_BIT	Converter Build-in-Self-Test Built-In-Test (BIT) = '1' indicates an error. The causes for an error are as follows: <ol style="list-style-type: none"> 1. Loss of Signal (LOS). Both input signals (+S/-S and +C/-C) drop below the threshold voltage of 500mV. 2. Phase Error. The input signal phase is more than 180° different from the reference signal phase. 3. Excessive Error. The digital output is more than a 100LSBs different from the input angle. 4. Loss of Reference (LOR). The reference input signal is less than 500mV On normal operation, a BIT occurs during large step changes of the input or on high accelerations that cause acceleration lag.	R	0

Figure 3-10: Channel Status Register

The direction indication is reliable only when the Encoder Emulation is active. If the Encoder Emulation is not active, this bit reflects the 'U'-output of the RDC19230, which is not reliable on static angles.

If CH_STA_BIT is read as '1' the resolution could be changed from its programmed value one step down to a lower resolution. This would allow the converter to settle out faster (see chapter 'Changing Resolution on the Fly').

3.2.7 Encoder Counter Preload/Data Register

A write access updates the Encoder Counter Preload Register. A read access reads the Encoder Counter Data Register.

Bit	Symbol	Description	Access	Reset
0-31	ENC_PRE	Encoder Counter Preload Register The Encoder Counter Preload Register is used in all modes for reference preload.	W	0
0-31	ENC_DATA	Encoder Counter Data Register The actual encoder counter value is latched into the Encoder Counter Data Register.	R	0

Figure 3-11: Encoder Counter Preload/Data Register

If the Multiple Encoder Read feature is used for the Encoder Counter Data Registers, a read access latches all counter values for the enabled counters at the same time. Then the Encoder Counter Data Registers can be read one after the other. A new Multiple Encoder Read access is only possible after finishing the read of all latched Encoder Counter Data Registers.

4 PCI9030 Target Chip

4.1 PCI Configuration Registers (PCR)

4.1.1 PCI9030 Header

PCI CFG Register Address	Write '0' to all unused (Reserved) bits							PCI writeable	Initial Values (Hex Values)	
	31	24	23	16	15	8	7			0
0x00	Device ID				Vendor ID				N	0096 1498
0x04	Status				Command				Y	0280 0000
0x08	Class Code					Revision ID			N	118000 0A
0x0C	BIST	Header Type		PCI Latency Timer		Cache Line Size		Y[7:0]	00 00 00 00	
0x10	PCI Base Address 0 for MEM Mapped Config. Registers							Y	FFFFFF80	
0x14	PCI Base Address 1 for I/O Mapped Config. Registers							Y	FFFFFF81	
0x18	PCI Base Address 2 for Local Address Space 0							Y	FFFFFF80	
0x1C	PCI Base Address 3 for Local Address Space 1							Y	00000000	
0x20	PCI Base Address 4 for Local Address Space 2							Y	00000000	
0x24	PCI Base Address 5 for Local Address Space 3							Y	00000000	
0x28	PCI Cardbus Information Structure Pointer							N	00000000	
0x2C	Subsystem ID			Subsystem Vendor ID				N	000A 1498	
0x30	PCI Base Address for Local Expansion ROM							Y	00000000	
0x34	Reserved					New Cap. Ptr.		N	000000 40	
0x38	Reserved							N	00000000	
0x3C	Max_Lat	Min_Gnt		Interrupt Pin		Interrupt Line		Y[7:0]	00 00 01 00	
0x40	PM Cap.			PM Nxt Cap.		PM Cap. ID		N	4801 00 01	
0x44	PM Data	PM CSR EXT		PM CSR				Y	00 00 0000	
0x48	Reserved	HS CSR		HS Nxt Cap.		HS Cap. ID		Y[23:16]	00 00 00 00	
0x4C	VPD Address			VPD Nxt Cap.		VPD Cap. ID		Y[31:16]	0000 00 03	
0x50	VPD Data							Y	00000000	

Figure 4-1 : PCI9030 Header

4.1.2 PCI Base Address Initialization

PCI Base Address Initialization is scope of the PCI host software.

PCI9030 PCI Base Address Initialization:

1. Write 0xFFFF_FFFF to the PCI9030 PCI Base Address Register.
2. Read back the PCI9030 PCI Base Address Register.
3. For PCI Base Address Registers 0:5, check bit 0 for PCI Address Space.
 - Bit 0 = '0' requires PCI Memory Space mapping
 - Bit 0 = '1' requires PCI I/O Space mapping

For the PCI Expansion ROM Base Address Register, check bit 0 for usage.

 - Bit 0 = '0': Expansion ROM not used
 - Bit 0 = '1': Expansion ROM used
4. For PCI I/O Space mapping, starting at bit location 2, the first bit set determines the size of the required PCI I/O Space size.

For PCI Memory Space mapping, starting at bit location 4, the first bit set to '1' determines the size of the required PCI Memory Space size.

For PCI Expansion ROM mapping, starting at bit location 11, the first bit set to '1' determines the required PCI Expansion ROM size.

For example, if bit 5 of a PCI Base Address Register is detected as the first bit set to '1', the PCI9030 is requesting a 32 byte space (address bits 4:0 are not part of base address decoding).
5. Determine the base address and write the base address to the PCI9030 PCI Base Address Register. For PCI Memory Space mapping the mapped address region must comply with the definition of bits 3:1 of the PCI9030 PCI Base Address Register.

After programming the PCI9030 PCI Base Address Registers, the software must enable the PCI9030 for PCI I/O and/or PCI Memory Space access in the PCI9030 PCI Command Register (Offset 0x04). To enable PCI I/O Space access to the PCI9030, set bit 0 to '1'. To enable PCI Memory Space access to the PCI9030, set bit 1 to '1'.

Offset in Config.	Description	Usage
0x10	PCI9030 LCR's MEM	Used
0x14	PCI9030 LCR's I/O	Used
0x18	PCI9030 Local Space 0	Used
0x1C	PCI9030 Local Space 1	Not used
0x30	Expansion ROM	Not used

Figure 4-2 : PCI9030 PLD Base Address Usage

4.2 Local Configuration Register (LCR)

After reset, the PCI9030 Local Configuration Registers are loaded from the on board serial configuration EEPROM.

The PCI base address for the PCI9030 Local Configuration Registers is PCI9030 PCI Base Address 0 (PCI Memory Space) (Offset 0x10 in the PCI9030 PCI Configuration Register Space) or PCI9030 PCI Base Address 1 (PCI I/O Space) (Offset 0x14 in the PCI9030 PCI Configuration Register Space).

Do not change hardware dependent bit settings in the PCI9030 Local Configuration Registers.

Offset from PCI Base Address	Register	Value	Description
0x00	Local Address Space 0 Range	0x0FFF FF80	Memory space
0x04	Local Address Space 1 Range	0x0000 0000	Not used
0x08	Local Address Space 2 Range	0x0000 0000	Not used
0x0C	Local Address Space 3 Range	0x0000 0000	Not used
0x10	Local Exp. ROM Range	0x0000 0000	Not used
0x14	Local Re-map Register Space 0	0x0000 0001	Enabled, Offset 0
0x18	Local Re-map Register Space 1	0x0000 0000	Not used
0x1C	Local Re-map Register Space 2	0x0000 0000	Not used
0x20	Local Re-map Register Space 3	0x0000 0000	Not used
0x24	Local Re-map Register ROM	0x0000 0000	Not used
0x28	Local Address Space 0 Descriptor	0x01B1 7B60	Local timing
0x2C	Local Address Space 1 Descriptor	0x0000 0000	Not used
0x30	Local Address Space 2 Descriptor	0x0000 0000	Not used
0x34	Local Address Space 3 Descriptor	0x0000 0000	Not used
0x38	Local Exp. ROM Descriptor	0x0000 0000	Not used
0x3C	Chip Select 0 Base Address	0x0000 0041	Chip select
0x40	Chip Select 1 Base Address	0x0000 0000	Not used
0x44	Chip Select 2 Base Address	0x0000 0000	Not used
0x48	Chip Select 3 Base Address	0x0000 0000	Not used
0x4C	Interrupt Control/Status	0x0043	Interrupt configuration
0x4E	EEPROM Write Protect Boundary	0x0030	Standard write protection
0x50	Miscellaneous Control Register	0x0078 0000	Retry delay = max
0x54	General Purpose I/O Control	0x0000 0000	All pins are outputs
0x70	Hidden1 Power Management data select	0x0000 0000	Not used
0x74	Hidden 2 Power Management data scale	0x0000 0000	Not used

Figure 4-3 : PCI9030 Local Configuration Register

4.3 Configuration EEPROM

After power-on or PCI reset, the PCI9030 loads initial configuration register data from the on board configuration EEPROM.

The configuration EEPROM contains the following configuration data:

- Address 0x00 to 0x27 : PCI9030 PCI Configuration Register Values
- Address 0x28 to 0x87 : PCI9030 Local Configuration Register Values
- Address 0x88 to 0xFF : Reserved

See the PCI9030 Manual for more information.

Address	Offset							
	0x00	0x02	0x04	0x06	0x08	0x0A	0x0C	0x0E
0x00	0x0096	0x1498	0x0280	0x0000	0x1180	0x000A	s.b.	0x1498
0x10	0x0000	0x0040	0x0000	0x0100	0x4801	0x0001	0x0000	0x0000
0x20	0x0000	0x0000	0x0000	0x0003	0x0FFF	0xFF80	0x0000	0x0000
0x30	0x0000	0x0000	0x0000	0x0000	0x0000	0x0000	0x0000	0x0001
0x40	0x0000	0x0000	0x0000	0x0000	0x0000	0x0000	0x0000	0x0000
0x50	0x01B1	0x7B60	0x0000	0x0000	0x0000	0x0000	0x0000	0x0000
0x60	0x0000	0x0000	0x0000	0x0041	0x0000	0x0000	0x0000	0x0000
0x70	0x0000	0x0000	0x0030	0x0043	0x0078	0x0000	0x0000	0x0000
0x80	0x0000	0x0000	0x0000	0x0000	0xFFFF	0xFFFF	0xFFFF	0xFFFF
0x90	0xFFFF	0xFFFF	0xFFFF	0xFFFF	0xFFFF	0xFFFF	0xFFFF	0xFFFF
0xA0	0xFFFF	0xFFFF	0xFFFF	0xFFFF	0xFFFF	0xFFFF	0xFFFF	0xFFFF
0xB0	0xFFFF	0xFFFF	0xFFFF	0xFFFF	0xFFFF	0xFFFF	0xFFFF	0xFFFF
0xC0	0xFFFF	0xFFFF	0xFFFF	0xFFFF	0xFFFF	0xFFFF	0xFFFF	0xFFFF
0xD0	0xFFFF	0xFFFF	0xFFFF	0xFFFF	0xFFFF	0xFFFF	0xFFFF	0xFFFF
0xE0	0xFFFF	0xFFFF	0xFFFF	0xFFFF	0xFFFF	0xFFFF	0xFFFF	0xFFFF
0xF0	0xFFFF	0xFFFF	0xFFFF	0xFFFF	0xFFFF	0xFFFF	0xFFFF	0xFFFF

Figure 4-4 : Configuration EEPROM TPMC150-xx

Subsystem-ID Value (Offset 0x0C):

- TPMC150-10 0x000A
- TPMC150-11 0x000B
- TPMC150-12 0x000C
- TPMC150-13 0x000D

4.4 Local Software Reset

The PCI9030 Local Reset Output LRESETo# is used to reset the on-board local logic.

The PCI9030 local reset is active during PCI reset or if the PCI Adapter Software Reset bit is set in the PCI9030 local configuration register CNTRL (offset 0x50).

CNTRL[30] PCI Adapter Software Reset:

Value of 1 resets the PCI9030 and issues a reset to the Local Bus (LRESETo# asserted). The PCI9030 remains in this reset condition until the PCI Host clears this bit. The contents of the PCI9030 PCI and Local Configuration Registers are not reset. The PCI9030 PCI Interface is not reset.

5 Configuration Hints

5.1 Software Reset (Controller and LRESET#)

A host on the PCI bus can set the software reset bit in the Miscellaneous Control Register (CNTRL; 50h) of the PCI Controller PCI9030 to reset the Controller and assert LRESET# output. The PCI9030 remains in this reset condition until the PCI host clears the software reset bit.

5.2 Big / Little Endian

- PCI – Bus (Little Endian)

Byte 0	AD[7..0]
Byte 1	AD[15..8]
Byte 2	AD[23..16]
Byte 3	AD[31..24]

- Every Local Address Space (0...3) and the Expansion ROM Space can programmed to operate in Big or Little Endian Mode.

Big Endian		Little Endian	
32 Bit		32 Bit	
Byte 0	D[31..24]	Byte 0	D[7..0]
Byte 1	D[23..16]	Byte 1	D[15..8]
Byte 2	D[15..8]	Byte 2	D[23..16]
Byte 3	D[7..0]	Byte 3	D[31..24]
16 Bit upper lane		16 Bit	
Byte 0	D[31..24]	Byte 0	D[7..0]
Byte 1	D[23..16]	Byte 1	D[15..8]
16 Bit lower lane			
Byte 0	D[15..8]		
Byte 1	D[7..0]		
8 Bit upper lane		8 Bit	
Byte 0	D[31..24]	Byte 0	D[7..0]
8 Bit lower lane			
Byte 0	D[7..0]		

Figure 5-1 : Local Bus Little/Big Endian

Standard use of the TPMC150:

Local Address Space 0	32 bit bus in Big Endian Mode
Local Address Space 1	not used
Local Address Space 2	not used
Local Address Space 3	not used
Expansion ROM Space	not used

To change the Endian Mode use the Local Configuration Registers for the corresponding Space. Bit 24 of the according register sets the Mode. A value of 1 indicates Big Endian and a value of 0 indicates Little Endian.

For further information please refer to the PCI9030 manual which is also part of the TPMC150-ED Engineering Documentation.

Use the PCI Base Address 0 + Offset or PCI Base Address 1 + Offset:

Short cut Offset	Name
LAS0BRD	0x28 Local Address Space 0 Bus Region Description Register
LAS1BRD	0x2C Local Address Space 0 Bus Region Description Register
LAS2BRD	0x30 Local Address Space 0 Bus Region Description Register
LAS3BRD	0x34 Local Address Space 0 Bus Region Description Register
EROMBRD	0x38 Expansion ROM Bus Region Description Register

You could also use the PCI - Base Address 1 I/O Mapped Configuration Registers.

5.3 Local read/write

The local register design is developed for a long word (32 bit) read/write access. A byte or word access could fail.

5.4 Changing Resolution on the Fly

A technique used to increase the tracking rate while maintaining low speed accuracy is to switch the resolution of the converter on the fly (sometimes called gear shifting). This allows the user to increase resolution when the input is changing at slow speeds, or decrease the resolution when high tracking rates are required. This change is accomplished by simply changing the digital resolution controls.

However, the change in resolution will introduce a transient in the output code as well as the velocity. This is due to internal gain changes when the resolution is switched.

This technique can also be used to reduce errors from large input steps or over velocity conditions. When the Build-In-Test of the converter indicates an error, the resolution can be changed from its programmed value one step down to a lower resolution. This allows the converter to settle out faster.

5.5 Operating Modes

5.5.1 Converter Operating Modes

5.5.1.1 Operating with Synchronous Status Latch

Operating with Synchronous Status Latch is separately selected for each channel if CH_SYN_LAT of the respective Channel Control Register is set to '1'. In this case, the Channel Status Register latches the status at Channel Data Register read time. The latch is released by a read access to the Channel Status Register. Subsequent reads to the Channel Data Register without reading the Channel Status Register will leave the Status Register unchanged, i.e. the latched Status Register will not be updated.

Sequence:

- read Data → freeze the status at data read
- read Status → release status latch
- check Build-In-Test → If CH_STA_BIT is read as '0', the data value is valid

5.5.1.2 Operating with Synchronous Conversion

Operating with Synchronous Conversion for Channel 1 and Channel 2 is selected if CH_SYN_CON of the Channel 1 Control Register is set to '1'. Operating with Synchronous Conversion for Channel 3 and Channel 4 is selected if CH_SYN_CON of the Channel 3 Control Register is set to '1'. In this case the value of channel 2 (channel 4) is converted simultaneously with channel 1 (channel 3). Status Registers are latched at Channel 1 (Channel 3) Data Register read time if the Synchronous Status Latch is enabled.

Sequence (example for channel 1 & 2):

- read channel 1 data → start conversion for channel 1 and 2
→ latch the status for channel 1 and 2 (if Synchronous Status Latch enabled)
- read channel 1 status → release latch of Channel 1 Status Register (if enabled)
- read channel 2 data → release Channel 2 Data Register
- read channel 2 status → release latch of Channel 2 Status Register (if enabled)
- Check Build-In-Test of both status registers → If CH_STA_BIT is read as '0', the data value is valid.

This feature may be useful, when two-speed-resolvers (coarse and fine) are used. Refer to the RDC19230 manual available on www.ddc-web.com for a software example.

5.5.1.3 Multiple Converter Read

If the Multiple Converter Read feature is used for the Channel Data Registers, a read access to one of the enabled Channel Data Registers starts a conversion for all the enabled converters at the same time. The data will be latched. The latched Channel Data Registers can then be read one after the other. A new Multiple Converter Read access is only possible after finishing the read of all latched Channel Data Registers.

During a Multiple Converter Read access CTRL_CON_STA is set to the value '1'. CTRL_CON_STA changes to '0' after the last read access to the enabled and latched Channel Data Registers.

The 'Synchronous Status Latch' and 'Synchronous Conversion' are not affected by this feature and will work as usual.

Registers may be reread within the multiple read sequence and will then contain current data. This will not affect the remaining unread registers.

5.5.2 Encoder Operating Modes

The Encoder Emulation is activated by writing a '1' to the CH_EMU_EN in the Channel Control Register. When CH_EMU_EN is set to '1', the current converter resolution is latched and used for the Incremental Encoder Emulation.

The converter resolution can be changed after the Incremental Encoder Emulation resolution is set, but it must not be less than the resolution of the Incremental Encoder Emulation. If the converter resolution is less than the Incremental Encoder Emulation resolution, there will be no Encoder Emulation output!

To enable the Incremental Encoder Emulation with a certain resolution and change the converter resolution afterwards, following steps have to be done:

Write access: Set the resolution to be used for the Incremental Encoder Emulation

Write access: Enable the Incremental Encoder Emulation

Write access: Set the converter resolution

5.5.2.1 Incremental Encoder Emulation Output

The Incremental Encoder Emulation Output can be used for systems that are designed to interface with incremental optical encoders. To enable the Encoder Emulation Output, write a '1' to the CH_EMU_OUT in the Channel Control Register.

The number of encoder pulses per revolution is dependent of the programmed Incremental Encoder Emulation Resolution:

Resolution/Bit	10	12	14	16
Encoder pulses per revolution	256	10240	4096	16384

Figure 5-2 : Incremental Encoder Resolution

The index pulse is high, when all the bits of the converter data are zero. If the converter resolution is programmed differently than the resolution of the Incremental Encoder Emulation the converter resolution will determine the resolution of the index pulse.

5.5.2.2 Encoder Signal Analysis Mode

The CH_ ESAM bits of the Channel Control Register define the encoder counter clock generation.

Value		Mode
0	0	disable Counter
0	1	1x – single
1	0	2x – double
1	1	4x – quad

Figure 5-3 : Encoder Signal Analysis Modes

The encoder counter can be programmed to interpret the encoder inputs as 1x, 2x or 4x clock, as described in figure 'Encoder Signal Analysis Modes' before.

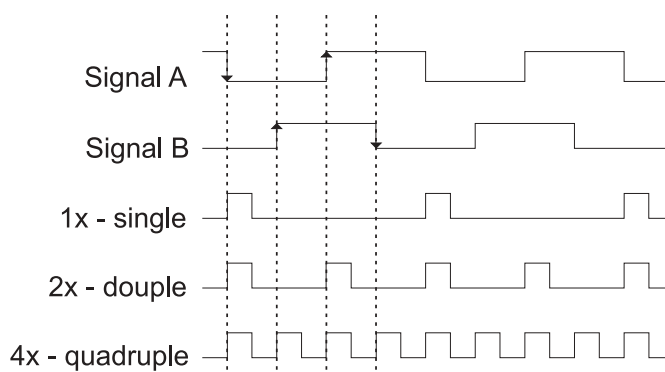

Figure 5-4 : Encoder signal interpretation

Encoder Signal Analysis Modes	Resolution/Bit			
	10	12	14	16
1x – single	256	1024	4096	16384
2x – double	512	2048	8192	32768
4x – quad	1024	4096	16384	65536

Figure 5-5 : Encoder count per revolution

To let the encoder counter count with the same resolution as set for encoder emulation, the Encoder Signal Analysis Mode must be set to 4x.

5.5.2.3 Reference Mode

The CH_REF bits of the Channel Control Register control the Encoder Reference Mode. The following table shows the available configurations:

Value		Mode
0	0	None Reference Mode
0	1	Reference Mode
1	0	Auto Reference Mode
1	1	Index Mode

Figure 5-6 : Encoder Reference Modes

None Reference Mode

In this mode there is no automatic preload of the encoder counter. Only a manual is possible. To make an encoder counter preload in this mode, a write access to the CTRL_PRE bits in the Global Control/Status Register is necessary.

Reference Mode

This mode controls the encoder counter with the corresponding digital 24V input (used as reference input) and the encoder index signal. A specified reference input signal and a following index impulse produce a counter preload. The host software must set the motion direction during such a reference access to backward.

The following figure shows the two normal preload accesses. An encoder motion area with eleven index pulses and the corresponding reference input is described as an example.

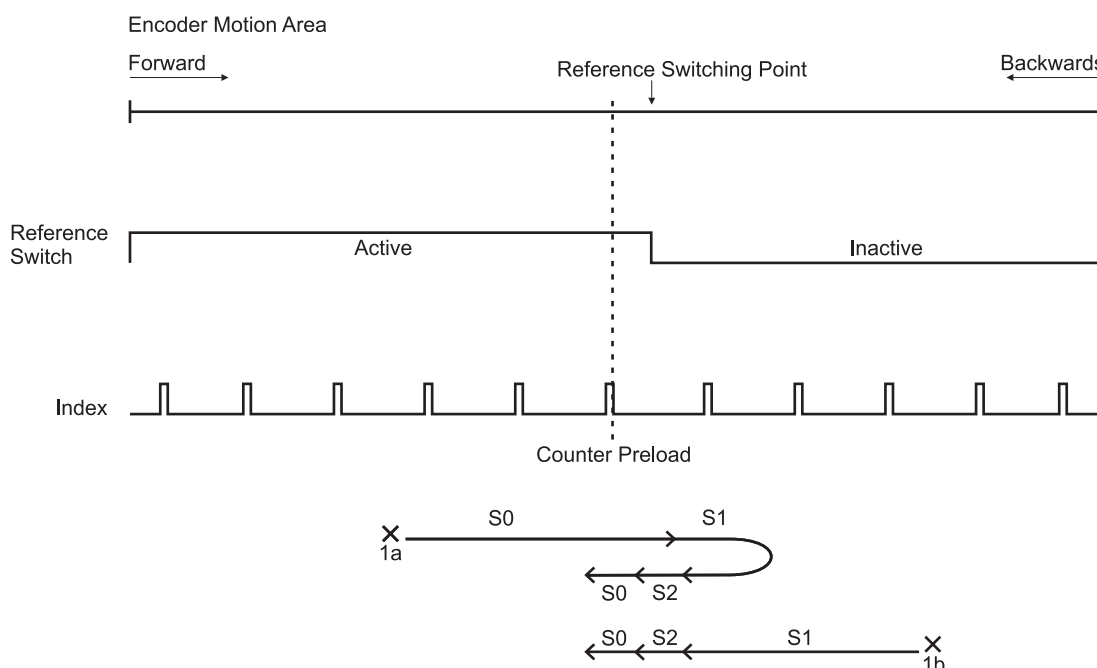

Figure 5-7 : Encoder preload example

Two different 'start positions' (1a and 1b) are shown:

Position 1a:

Direction is forward and the reference input is active. The host software must move into the area where the reference input is inactive. Now the direction must be changed. The next index pulse after entering the area with reference input active triggers the preload function of the encoder counter.

Position 1b:

Direction is backwards and the reference input is inactive. The host software must move further backwards, and after entering the area with reference input active the next index pulse triggers the preload function of the encoder counter.

A correct execution of the reference function can be monitored in the Channel Control Register. After successful execution the mode of this encoder is changed from bit combination '01' (Reference Mode) to '00' (None Reference Mode).

It must be guaranteed that the encoder motion area is divided into two areas, one with reference input active and one with reference input inactive.

Auto Reference Mode

This mode is the automation of the Reference Mode. That means every time the reference switching point and a following index pulse are crossed during backwards direction, a new preload is generated. **In Auto Reference Mode there is no change of the mode in the Channel Control Register!**

Index Mode

In this mode the digital 24V input is not used. Only the index impulse produces a counter preload. After setting this mode, the next occurrence of the index signal, independent from direction, will preload the counter. A correct execution of this preload function can be monitored in the Channel Control Register. After successful execution the mode of this encoder is set from bit combination '11' (Index) to '00' (None Reference Mode).

5.5.2.4 Multiple Encoder Read

If the Multiple Encoder Read feature is used for the Encoder Counter Data Registers, a read access one of the enabled Encoder Counter Data Registers latches all counter values for the enabled counters at the same time. Then the Encoder Counter Data Registers can be read one after the other. A new Multiple Encoder Read access is only possible after finishing the read of all latched Encoder Counter Data Registers.

During a Multiple Encoder Read access CTRL_ENC_STA is set to the value '1'. CTRL_ENC_STA changes to '0' after the last read access to the enabled and latched Encoder Counter Data Registers.

Registers may be reread within the multiple read sequence and will then contain current data. This will not affect the remaining unread registers.

5.6 Binary Angle Relationships

Resolution in Bits	2 ⁿ	LSB as % of full scale	Degrees/Bit	Minutes/Bit	Radians/Bit
0	1	100	360	21600	6.28318531
1	2	50	180	10800	3.14159265
2	4	25	90	5400	1.57079633
3	8	12.5	45	2700	0.78539816
4	16	6.25	22.5	1350	0.39269908
5	32	3.125	11.25	675	0.19634954
6	64	1.5625	5.625	337.5	0.09817477
7	128	0.78125	2.8125	168.75	0.04908739
8	256	0.390625	1.40625	84.375	0.02454369
9	512	0.1953125	0.703125	42.1875	0.01227185
10	1024	0.09765625	0.3515625	21.09375	0.00613592
11	2048	0.04882813	0.1757813	10.54686	0.00306796
12	4096	0.02441406	0.0878906	5.27344	0.00153398
13	8192	0.01220703	0.0439453	2.63672	0.00076699
14	16384	0.00610352	0.0219727	1.31836	0.00038350
15	32768	0.00305176	0.0109863	0.65918	0.00019175
16	65536	0.00152588	0.0054932	0.32959	0.00009587

Figure 5-8 : Binary Angle Relationships

$$\text{Angle in degrees} = \frac{\text{Data} \cdot 360^\circ}{2^{16}}$$

$$\text{Angle in minutes} = \frac{\text{Data} \cdot 21600'}{2^{16}}$$

$$\text{Angle in radians} = \frac{\text{Data} \cdot 2\pi}{2^{16}}$$

6 Signal Conditioning Adapter

Each synchro/resolver channel has to be equipped with a Signal Conditioning Adapter (TPMC150-Ay-xx) to adapt the signal levels of the synchro/resolver to the RDC19230 inputs and to configure the optional reference oscillator input/output. Each channel can be equipped with an individual Signal Conditioning Adapter, it is not necessary to equip all channels with the same adapter. The Signal Conditioning Adapters will be built individually to customer specification of the synchro or resolver specifications (replacing the 'xx'). The adapters are factory installed on the TPMC150.

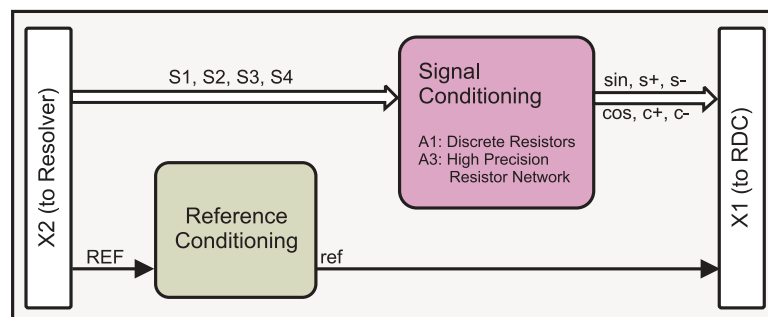

Figure 6-1 : Signal Conditioning Adapter TPMC150-A1/A3

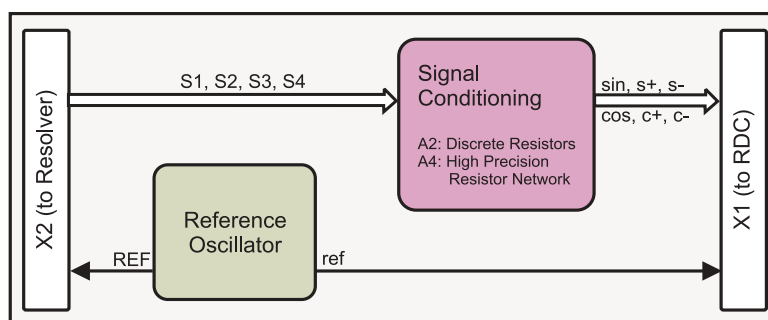

Figure 6-2 : Signal Conditioning Adapter TPMC150-A2/A4 with reference oscillator

Four types of Signal Conditioning Adapters are available: The TPMC150-A1 and the TPMC150-A2 use high precision, low TK discrete resistors. These adapters are mainly used for resolver applications. The TPMC150-A3 and the TPMC150-A4 use a high precision resistor network with matched resistors. These adapters are mainly used for synchro applications or resolver applications which require highest accuracy. Additionally the TPMC150-A2 and the TPMC150-A4 offer an on board reference oscillator with factory selectable frequencies in the range of 2 kHz to 10 kHz.

Main Variant	A1	A2	A3	A4
Discrete resistors	X	X		
Resistor network			X	X
Resolver	X	X	X	X
Synchro			X	X
High accuracy			X	X
Reference oscillator		X		X

Figure 6-3 : TPMC150 Adapter Variants

6.1 Signal Conditioning Adapter Characteristics

Reference Oscillator Output	
Frequency	1-10kHz, factory selectable
Amplitude	Max. 11.8V / 70mA
Signal Input	
Frequency	Resolution dependent
Signal Voltage	Factory selectable
Reference Input Voltage	Factory selectable
Physical Data	
Power Requirements (TPMC150-A2/A4 only, no load)	8mA typical @ +5V DC 8mA typical @ -5V DC 5mA typical @ +12V DC 5mA typical @ -12V DC
Temperature Range	Operating -40°C to +85 °C Storage -40°C to +125°C
MTBF	1 880 000 h (TPMC150-A1) 1 300 000 h (TPMC150-A2) 1 901 000 h (TPMC150-A3) 1 310 000 h (TPMC150-A4)
Humidity	5 – 95 % non-condensing
Weight	2-3 g

Figure 6-4 : Technical Specification TPMC150-A1 – TPMC150-A4

6.2 Required Synchro/Resolver specifications

To find a Signal Conditioning Adapter that fits to your synchro/resolver, TEWS TECHNOLOGIES requires the synchro/resolver specification. These are:

- Sensor type (resolver/synchro)
- Signal voltage (resolver: single ended/differential)
- Reference input voltage (single ended/differential)
- Optional: Reference output voltage/frequency

6.3 Connector Pin Assignments

6.3.1 20 Pin Connector - Front-I/O Side

Function and pin numbers are valid for X2, X4, X6, X8

Pin	Function	Dir.	Pin	Function	Dir.
1	+REF_EXT	in/out	2	n.c.	-
3	n.c.	-	4	-REF_EXT	in/out
5	n.c.	-	6	n.c.	-
7	S1	in	8	n.c.	-
9	n.c.	-	10	S2	in
11	n.c.	-	12	n.c.	-
13	S3	in	14	n.c.	-
15	n.c.	-	16	S4	in
17	n.c.	-	18	n.c.	-
19	n.c.	-	20	n.c.	-

Figure 6-5 : Pin Assignment - 20 Pin Connector Front I/O Side

6.3.2 20 Pin Connector - Converter Side

Function and pin numbers are valid for X1, X3, X5, X7

Pin	Function	Dir.	Pin	Function	Dir.
1	-REF	out	2	+REF	out
3	+5 V	-	4	-12 V	-
5	+C	out	6	LOS	out
7	COS	out	8	n.c.	-
9	-C	out	10	n.c.	-
11	+S	out	12	n.c.	-
13	Sin	out	14	n.c.	-
15	-S	out	16	n.c.	-
17	-5 V	-	18	+12 V	-
19	AGND	-	20	GND	-

Figure 6-6 : Pin Assignment - 20 Pin Connector Converter Side

7 Installation Hints

When a 90V signal input is used, make sure that the voltage rating of the I/O connector is sufficient to operate with the signal voltage.

Suggested mating connectors:

HARTING: *har-mik* series, 6003 068 5210

Make sure that the cable used to connect the TPMC150 with the synchro/resolver also has a voltage rating which is sufficient for the signal voltage.

Due to the concept of Signal Conditioning Adapter (TPMC150-Ay-xx), the TPMC150 uses the maximum board height which is allowed by the PMC specification.

To avoid damage of the carrier board and/or of the TPMC150 please make sure that there are no conductive components like ceramic PGA's under the PMC socket used for the TPMC150.

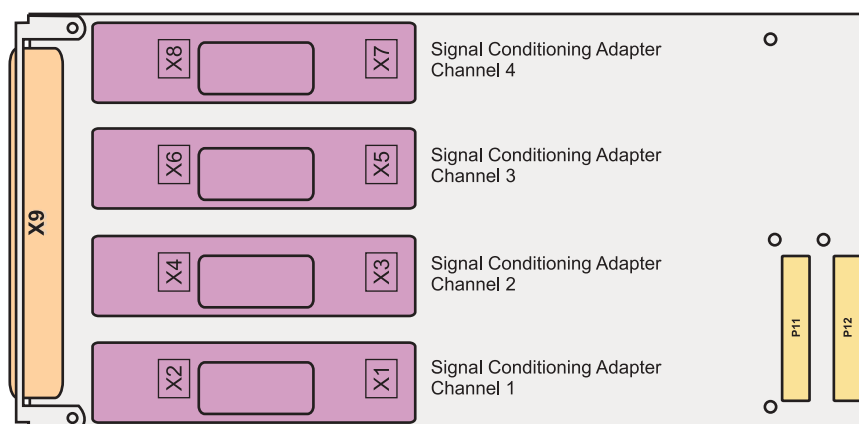

Figure 7-1 : TPMC150 Adapter Placement

7.1 Connection Examples

The following pages display several examples how to connect different synchro/resolver configurations to the TPMC150. All examples refer to channel 1. The other channels are connected accordingly (for pin numbers refer to the pin assignment table in chapter 'Pin Assignment').

7.1.1 Resolver with external reference

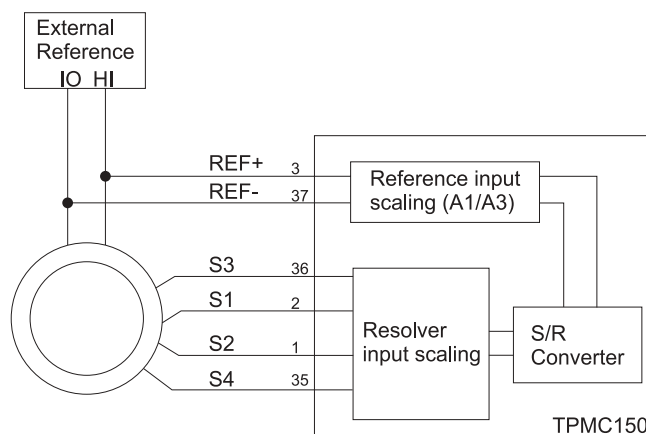

Figure 7-2 : Resolver with external reference

7.1.2 Resolver with internal reference

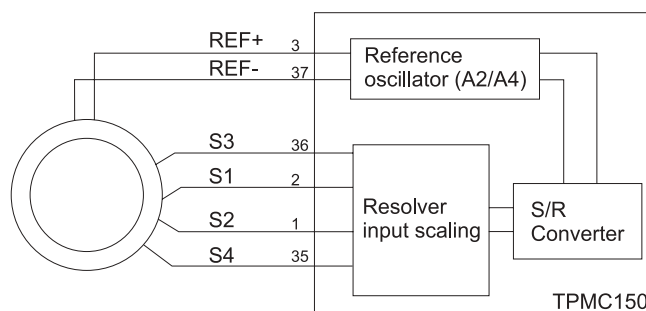

Figure 7-3 : Resolver with internal reference

7.1.3 Single ended resolver with external reference

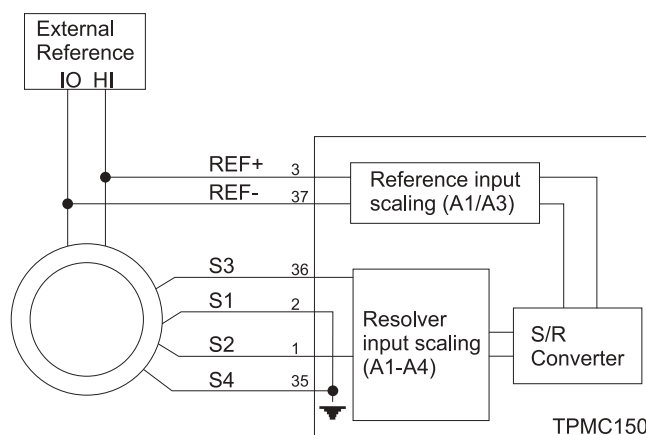

Figure 7-4 : Single ended resolver with external reference

7.1.4 Synchro with external reference

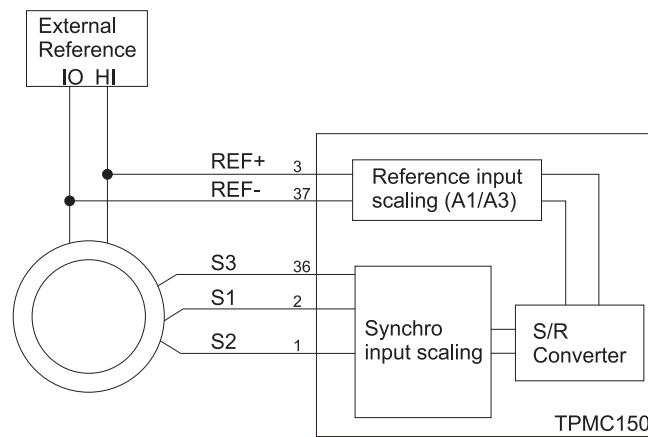

Figure 7-5 : Synchro with external reference

8 Pin Assignment – I/O Connector

The complete TPMC150 I/O interface is available on the HD68 SCSI-3 type connector ("front I/O"). There is no PMC P14 I/O.

Pin	Function	Dir.	Pin	Function	Dir.
1	Channel 1 S3 (sin+)	in	35	Channel 1 S4 (cos-)	in
2	Channel 1 S1 (sin-)	in	36	Channel 1 S2 (cos+)	in
3	Channel 1 Reference+	in/out	37	Channel 1 Reference-	in/out
4	Channel 1 A-	out	38	Channel 1 A+	out
5	Channel 1 B-	out	39	Channel 1 B+	out
6	Channel 1 ZI-	out	40	Channel 1 ZI+	out
7	Channel 1 Velocity output	out	41	AGND	
8	Channel 2 S3 (sin+)	In	42	Channel 2 S4 (cos-)	in
9	Channel 2 S1 (sin-)	In	43	Channel 2 S2 (cos+)	in
10	Channel 2 Reference +	in/out	44	Channel 2 Reference -	in/out
11	Channel 2 A-	out	45	Channel 2 A+	out
12	Channel 2 B-	out	46	Channel 2 B+	out
13	Channel 2 ZI-	out	47	Channel 2 ZI+	out
14	Channel 2 Velocity output	out	48	AGND	
15	Channel 3 S3 (sin+)	in	49	Channel 3 S4 (cos-)	in
16	Channel 3 S1 (sin-)	in	50	Channel 3 S2 (cos+)	in
17	Channel 3 Reference +	in/out	51	Channel 3 Reference -	in/out
18	Channel 3 A-	out	52	Channel 3 A+	out
19	Channel 3 B-	out	53	Channel 3 B+	out
20	Channel 3 ZI-	out	54	Channel 3 ZI+	out
21	Channel 3 Velocity output	out	55	AGND	
22	Channel 4 S3 (sin+)	in	56	Channel 4 S4 (cos-)	in
23	Channel 4 S1 (sin-)	in	57	Channel 4 S2 (cos+)	in
24	Channel 4 Reference +	in/out	58	Channel 4 Reference -	in/out
25	Channel 4 A-	out	59	Channel 4 A+	out
26	Channel 4 B-	out	60	Channel 4 B+	out
27	Channel 4 ZI-	out	61	Channel 4 ZI+	out
28	Channel 4 Velocity output	out	62	AGND	
29	NC		63	NC	
30	NC		64	NC	
31	DI_GND 1		65	DI_GND 2	
32	Digital Input 1	in	66	Digital Input 2	in
33	DI_GND 3		67	DI_GND 4	
34	Digital Input 3	in	68	Digital Input 4	in

Figure 8-1 : Pin Assignment I/O Connector