



# MVME7616E Transition Module

## Installation and Use

6806800A43B

August 2008



Ehlbeek 15a  
30938 Burgwedel  
fon 05139-9980-0  
fax 05139-9980-49

[www.powerbridge.de](http://www.powerbridge.de)  
[info@powerbridge.de](mailto:info@powerbridge.de)

© Copyright 2008 Emerson  
All rights reserved.

## Trademarks

Emerson, Business-Critical Continuity, Emerson Network Power and the Emerson Network Power logo are trademarks and service marks of Emerson Electric Co. © 2008 Emerson Electric Co.

All other trademarks are the property of their respective owners.

Intel® is a trademark or registered trademark of Intel Corporation or its subsidiaries in the United States and other countries.

Microsoft®, Windows® and Windows Me® are registered trademarks of Microsoft Corporation; and Windows XP™ is a trademark of Microsoft Corporation.

PICMG®, CompactPCI®, AdvancedTCA™ and the PICMG, CompactPCI and AdvancedTCA logos are registered trademarks of the PCI Industrial Computer Manufacturers Group.

UNIX® is a registered trademark of The Open Group in the United States and other countries.

## Notice

While reasonable efforts have been made to assure the accuracy of this document, Emerson assumes no liability resulting from any omissions in this document, or from the use of the information obtained therein. Emerson reserves the right to revise this document and to make changes from time to time in the content hereof without obligation of Emerson to notify any person of such revision or changes.

Electronic versions of this material may be read online, downloaded for personal use, or referenced in another document as a URL to a Emerson website. The text itself may not be published commercially in print or electronic form, edited, translated, or otherwise altered without the permission of Emerson,

It is possible that this publication may contain reference to or information about Emerson products (machines and programs), programming, or services that are not available in your country. Such references or information must not be construed to mean that Emerson intends to announce such Emerson products, programming, or services in your country.

## Limited and Restricted Rights Legend

If the documentation contained herein is supplied, directly or indirectly, to the U.S. Government, the following notice shall apply unless otherwise agreed to in writing by Emerson.

Use, duplication, or disclosure by the Government is subject to restrictions as set forth in subparagraph (b)(3) of the Rights in Technical Data clause at DFARS 252.227-7013 (Nov. 1995) and of the Rights in Noncommercial Computer Software and Documentation clause at DFARS 252.227-7014 (Jun. 1995).

## Contact Address

Emerson Network Power - Embedded Computing  
2900 South Diablo Way, Suite 190  
Tempe, AZ 85282  
USA

# Contents

---

<b>About this Manual</b> .....	<b>9</b>
<b>1 General Information</b> .....	<b>13</b>
1.1 Overview .....	13
1.2 Features .....	13
1.3 General Description .....	13
1.4 Serial Port Interface Modules .....	14
1.5 P2 Adapter Boards .....	15
1.6 Three-row P2 Adapter (MVME761-001) .....	15
1.7 Five-Row P2 Adapter (MVME761-011) .....	16
1.8 Connectors and Cables .....	16
1.9 Specifications .....	18
1.10 Cooling Requirements .....	18
1.11 FCC Compliance .....	18
<b>2 Hardware Preparation and Installation</b> .....	<b>19</b>
2.1 Overview .....	19
2.2 Unpacking the Hardware .....	19
2.3 Installing the Serial Interface Modules .....	19
2.4 Installing the Transition Module and P2 Adapter .....	22
<b>3 Functional Description</b> .....	<b>25</b>
3.1 Overview .....	25
3.2 Circuitry .....	25
3.3 P2 Signal Multiplexing (P2MX) .....	27
3.4 Serial Interface Module Circuitry .....	29
3.5 COM1 and COM2 Asynchronous Serial Ports .....	30
3.6 Asynchronous/Synchronous Serial Ports .....	31
<b>4 Connector Pin Assignments</b> .....	<b>35</b>
4.1 Overview .....	35
4.2 P2 Connector .....	35
4.3 Asynchronous Serial Port Connectors (J5/J6) .....	36
4.4 Asynchronous/Synchronous serial Port connectors (J7/J8) .....	37
4.5 Parallel I/O Port Connector (J4) .....	38
4.6 Ethernet Connector (J9) .....	39
4.7 P2 Adapter Connectors .....	39

## Contents

---

4.7.1	3-Row P2 Adapter (J2)	39
4.7.2	3-Row P2 Adapter (J3)	40
4.7.3	5-Row P2 adapter (J1)	41
4.7.4	PMC I/O, 5-Row P2 Adapter (J3)	42
4.7.5	5-Row P2 adapter (J4)	43

# List of Tables

---

Table 1-1	SIM Part Numbers	15
Table 1-2	MVME761 Transition Module Connectors	16
Table 1-3	3-Row P2 Adapter Connectors (MVME761-001)	17
Table 1-4	5-Row P2 Adapter Connectors (MVME761-011)	17
Table 1-5	Transition Module Cables	17
Table 1-6	MVME761-0x1 Specifications	18
Table 3-1	P2 signal multiplexing sequence	28
Table 4-1	P2 Connector Pin Assignments	35
Table 4-2	COM1 and COM2 Pin Assignments	36
Table 4-3	Serial Port 3 Pin Assignments	37
Table 4-4	Serial Port 4 Pin Assignments	37
Table 4-5	Parallel I/O Connector Pin Assignments	38
Table 4-6	10Base-T/100Base-TX Pin Assignments	39
Table 4-7	8-bit SCSI Connector (3-Row P2 adapter)	39
Table 4-8	VME Connector (3-Row P2 adapter)	40
Table 4-9	16-bit SCSI Connector (5-Row P2 adapter)	41
Table 4-10	PMC I/O Connector (5-Row P2 adapter)	42
Table 4-11	VME Connector (3-Row P2 adapter)	43



# List of Figures

---

Figure 1-1	RTM Front Panel and Components Side	14
Figure 1-2	Three Row P2 Adapter	15
Figure 1-3	Five Row P2 Adapter	16
Figure 2-1	Serial Port Interface Jumper Setting	19
Figure 2-2	SIM Configuration	20
Figure 2-3	Installing the SIM	21
Figure 2-4	Chassis Connections	23
Figure 3-1	Transition Module Block Diagram	26
Figure 3-2	3-Row DIN Backplane P2 Adapter Block Diagram	26
Figure 3-3	5-Row DIN Backplane P2 Adapter Block Diagram	27
Figure 3-4	Multiplex Signal Timing Chart	29
Figure 3-5	EIA-574 DTE Port Configuration	30
Figure 3-6	EIA232-DCE Copnfiguration Port 3	31
Figure 3-7	EIA232-DCE Configuration Port 4	32
Figure 3-8	EIA232-DTE Configuration Port 3	33
Figure 3-9	EIA232-DTE Configuration Port 4	34





# About this Manual

---

## Overview of Contents

This manual is divided into the following chapters and appendices:

[Chapter 1, General Information](#)

[Chapter 2, Hardware Preparation and Installation](#)

[Chapter 3, Functional Description](#)

[Chapter 4, Connector Pin Assignments](#)

*MVME7616E Transition Module Installation and Use* provides general information, hardware preparation, installation instructions and support information for the MVME7616E-001 and MVME7616E-011 Transition Modules. These transition modules are used as the interface between the variants of the MVME51005E and MVME55006E Single Board Computers. A P2 adapter module and cable are supplied with the MVME7616E. The MVME7616E will hereafter be referred to as the MVME761.

As of the printing date of this manual, these I/O module models are available:

Model Number	Description
MVME7616E-001 MVME7616E-011	3-Row Rear Transition Module and P2 Adaptor 5-Row Rear Transition Module and P2 Adaptor
MVME761P26E-001 MVME761P2-6E011	3-Row, P2 Adapter Module Only 5-Row, P2 Adapter Module Only
Related Product	
MVME51005E MVME51105E	MVME Series MVME51005E Single Board Computer
MVME55006E	MVME Series MVME55006E Single Board Computer
IPMC7616E-001 IPMC7616E-002	Multifunction rear I/O PMC module; Ultra-Wide SCSI, one parallel port, three asynchronous and one synchronous/asynchronous serial port
SIM232DCE5E SIM232DTE5E	EIA232-DCE serial interface module EIA232-DTE serial interface module

## Abbreviations

This document uses the following abbreviations:

Abbreviation	Description
AC	Alternating Current
CFM	Cubic Feet per Minute
D/C	Direct Current
DCE	Data Communications Equipment
DIN	Deutsches Insitut für Normung eV
DTE	Data Terminal Equipment
EMI	Electro-Magnetic Interference
ESD	Electro-Static Discharge
FCC	Federal Communications Commission
GND	Ground
I/O	Input/Output
IC	Integrated Circuit
IEEE	Institute of Electrical and Electronics Engineers
PMC	PCI Mezzanine Card
RF	Radio Frequency
RTM	Rear Transition Module
SCSI	Small Computer System Interface
SIM	Serial Interface Module
VME	Versamodule Eurocard

## Conventions

The following table describes the conventions used throughout this manual.

Notation	Description
0x00000000	Typical notation for hexadecimal numbers (digits are 0 through F), for example used for addresses and offsets
0b0000	Same for binary numbers (digits are 0 and 1)
<b>bold</b>	Used to emphasize a word
<code>Screen</code>	Used for on-screen output and code related elements or commands in body text
<b>Courier + Bold</b>	Used to characterize user input and to separate it from system output
<i>Reference</i>	Used for references and for table and figure descriptions



## Comments and Suggestions

We welcome and appreciate your comments on our documentation. We want to know what you think about our manuals and how we can make them better.

Mail comments to us by filling out the following online form:

<http://www.emersonnetworkpowerembeddedcomputing.com/> > Contact Us > Online Form

In "Area of Interest" select "Technical Documentation". Be sure to include the title, part number, and revision of the manual and tell us how you used it.

## 1.1 Overview

This manual provides general information, hardware preparation, installation instructions, and a functional description for the MVME761-001 and MVME761-011 Transition Modules.

The MVME761-0x1 Transition Module provides the interface between the MVME5100 or MVME5500

Single Board Computer VME modules and various peripheral devices. This module provides industry standard connectors to simplify customer cable requirements for the serial port, printer, and Ethernet signals.

## 1.2 Features

The features of the MVME761-0x1 Transition Module include:

- Industry-standard connectors for these interfaces:
  - Two EIA-574 asynchronous serial ports (DTE)
  - Two asynchronous/synchronous serial ports, configured for EIA-232-D (DCE or DTE)
  - One parallel port (IEEE Standard 1284-I compliant)
  - 10Base-T/100Base-TX Ethernet
- Two 60-pin Serial Interface Module (SIM) connectors for configuring the asynchronous/synchronous serial ports
- Single-width board
- Electro-Magnetic Interference (EMI) and Electro-Static Discharge (ESD) protection

## 1.3 General Description

The MVME761-0x1 Transition Module provides the interface between the standard Ethernet, parallel port, and the serial port connectors on a variety of single board computers. All port I/O controllers reside on the host VME modules. The MVME761 transition module Ethernet and parallel port circuitry is passive. The serial port circuitry provides multiplexing and buffering functions (refer to [P2 Signal Multiplexing \(P2MX\) on page 27](#)). The multiplexing function is transparent to the user.

Both MVME761-0x1 models use the same transition module. The MVME761-001 comes with a P2 adapter that connects to a 3-row DIN chassis backplane. The MVME761-011 comes with a P2 adapter that connects to a 5-row DIN chassis backplane.

Figure 1-1 shows the MVME761 transition module component layout and the front panel. See Table 1-2 for a list of the front panel port connectors.

Figure 1-1 RTM Front Panel and Components Side

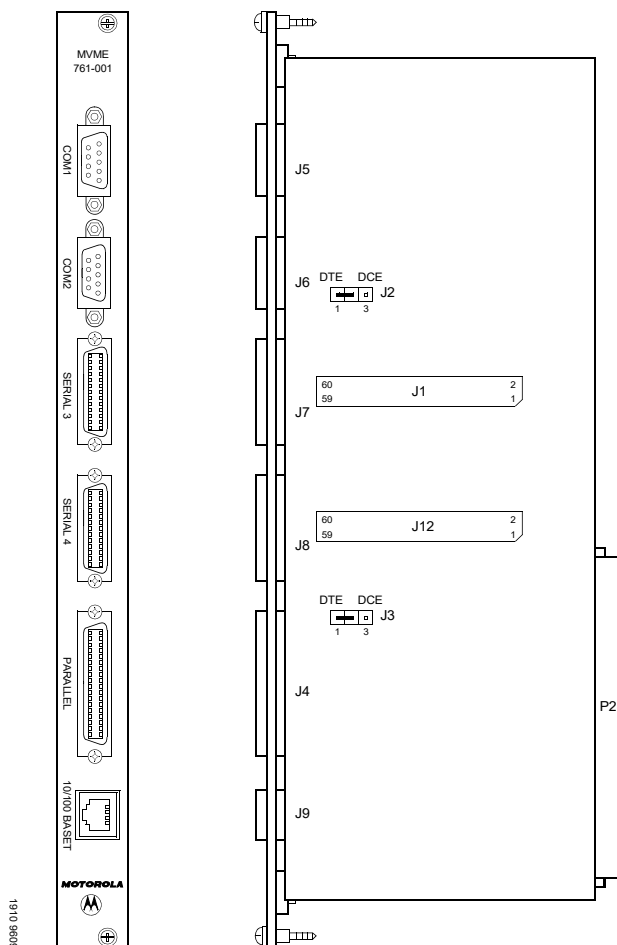

## 1.4 Serial Port Interface Modules

You may configure the asynchronous/synchronous serial ports (ports 3 and 4) to the appropriate interface by installing a Serial Interface Module (SIM). A SIM is a small “plug-in” printed circuit board that converts the TTL-level synchronous or asynchronous port signals to industry standard voltage levels used by the ports. The SIM contains the receiver and transmitter circuits for converting the input and output signals of the host VME module to the appropriate serial data communication protocol.

The SIMs for the MVME761 are listed in the following table.

Table 1-1 SIM Part Numbers

Interface	Model Number	Part Number
EIA-232-D DCE	SIM232DCE5E	01-W3876B11A
EIA-232-D DTE	SIM232DTE5E	01-W3877B11A

Additional SIMs may be released. Please see your Emerson representative for a complete list of SIMS that are available for the MVME761-0x1.

## 1.5 P2 Adapter Boards

The P2 adapters route the asynchronous and synchronous port, printer port, and Ethernet signals to the MVME761 transition module.

## 1.6 Three-row P2 Adapter (MVME761-001)

The P2 adapter for the MVME761-001 mounts onto a 3-row, 96-pin P2 backplane connector. The 50-pin male connector, J2, carries the 8-bit SCSI signals from the host VME modules. To run SCSI devices, you may install an additional transition module that is equipped with a SCSI port, such as the MVME712B.

Figure 1-2 Three Row P2 Adapter

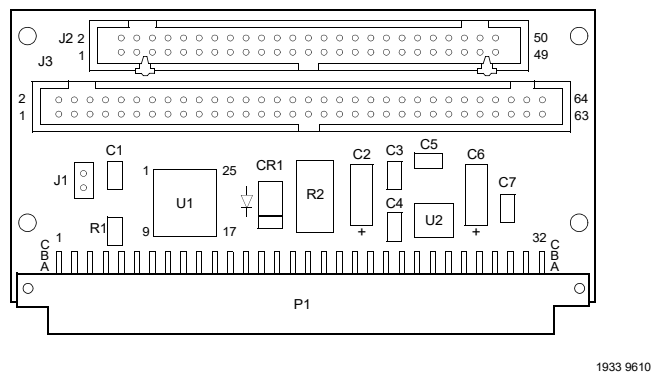

1933 9610

This P2 adapter, and the cable for connecting to the MVME761 transition module, can be ordered separately as model MVME761P2-001.

## 1.7 Five-Row P2 Adapter (MVME761-011)

The P2 adapter for the MVME761-011 mounts onto a 5-row, 160-pin P2 backplane connector. The 68-pin female connector, J1, carries 16-bit SCSI signals from the host VME modules. It also has a 64-pin male connector, J3, for PMC I/O.

Figure 1-3 Five Row P2 Adapter

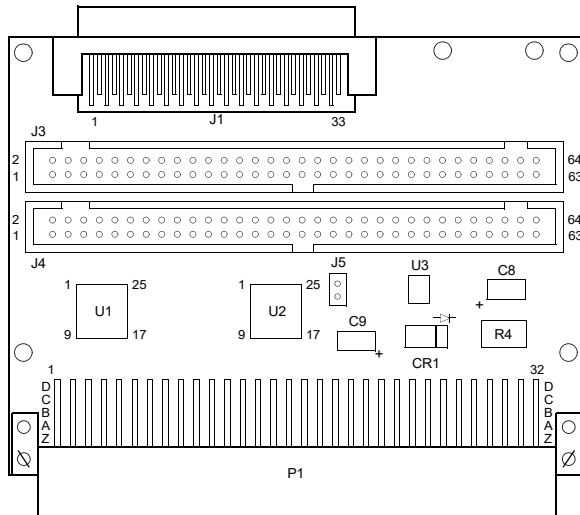

This P2 adapter, and the cable for connecting to the MVME761 transition module, can be ordered separately as model MVME761P2-011.

## 1.8 Connectors and Cables

The connectors on the MVME761 transition module and the P2 adapters are listed in the following tables. The port connectors are located on the front panel, which is shown in Figure 1-1. See Table 1-5 on page 17 for a list of the cables. See Chapter 4, Connector Pin Assignments.

The cable used for connecting the MVME761 transition module to the P2 adapter is provided with the MVME761-0x1

1. You will need to purchase or fabricate the port cables.

Table 1-2 MVME761 Transition Module Connectors

Type	Number	Description
COM1 and COM2	J5 J6	9-pin male DIN asynchronous serial port connector
Serial port 3 Serial port 4	J7 J8	26-pin female HD-26 synchronous serial port connector



Table 1-2 MVME761 Transition Module Connectors (continued)

Type	Number	Description
Parallel port	J4	36-pin female parallel port connector
10Base-T, 100Base-TX	J9	8-pin female RJ-45 Ethernet port connector
SIM	J1, J12	60-pin female connector
VME	P2	64-pin male connector to J2 on the P2 adapter

Table 1-3 3-Row P2 Adapter Connectors (MVME761-001)

Type	Number	Description
VME	P1	96-pin female DIN 41612 connector to the chassis backplane
	J3	64-pin male connector for output to P2 on the MVME761 transition module
SCSI	J2	50-pin male IDC connector for internal SCSI devices

Table 1-4 5-Row P2 Adapter Connectors (MVME761-011)

Type	Number	Description
VME	P1	160-pin female DIN 41612 connector to the chassis backplane
	J4	64-pin male connector for output to P2 on the MVME761 transition module
PMC I/O	J3	64-pin male connector for PMC I/O
SCSI	J1	68-pin female IDC connector for internal SCSI devices

Table 1-5 Transition Module Cables

Part Number	Description
Included with the MVME761-0x1	64-line flat ribbon cable with 96-pin DIN connectors that connects P2 on the MVME761 transition module to J3 on the 3-row P2 Adapter or J4 on the 5-row P2 adapter; 13 inches long. (30-W2799B02A).
User-supplied	EIA-232-D DTE or DCE cable (pins used depend on the processor VME module)
User-supplied	Centronics- type parallel printer cable, male-to-male
User-supplied	20-conductor cable; usually supplied with the modem
User-supplied	6-conductor cable; usually supplied with the modem
CBL761HD26DB25	Straight-through adapter cable with male HD-26 connector and female DB-25 connector, 3 feet long. (30-NW9302B27)
If you supply your own 64-line cable to connect the P2 adapter to the MVME761 transition module, the cable should not be longer than 1.5 feet. A longer cable is likely to cause problems, especially for the Ethernet and parallel port signals.	

## 1.9 Specifications

The MVME761 transition module specifications are shown in the next table.

Table 1-6 MVME761-0x1 Specifications

Characteristics	Specifications
Power Requirements	+12 Vdc, 100 mA typical, 200 mA maximum -12 Vdc, 100 mA (for some of the SIMs)
Operating temperature	0° to 55° C at chassis point of entry of forced air (approximately 5 CFM)
Storage temperature	-40° to +85° C
Relative Humidity	5% to 90% (non-condensing)
Board Size (excluding front panel)	Height: 9.187 inches(233.35 mm) Height: 3.200 inches(80.00 mm) Thickness: 0.063 inches (1.60 mm)

## 1.10 Cooling Requirements

The MVME761-0x1 is tested to operate under forced air cooling with an incoming air temperature range of 0 degrees C to 55 degrees C. Adequate cooling can be achieved with air flowing over the module at 5 cubic feet per minute. The exact amount of airflow required for cooling depends on the ambient air temperature and the type, number, and location of modules and other heat sources.

## 1.11 FCC Compliance

The MVME761-0x1 was tested in an FCC-compliant chassis, and meets the requirements for Class A equipment. For minimum RF emissions, it is essential that you implement the following conditions:

- Install shielded cables on all external I/O ports
- Connect conductive chassis rails to earth ground to provide a path for connecting shields to earth ground
- Tighten all front panel screws

## 2.1 Overview

This chapter provides unpacking instructions, hardware preparation, and installation instructions for the MVME761 transition module, the P2 adapter, and the Serial Interface Modules (SIMs).

## 2.2 Unpacking the Hardware

The MVME761 is packed in an antistatic wrapper to protect it from static discharge. Emerson strongly recommends that you use an antistatic wrist strap and a conductive foam pad when handling the equipment. Electronic components can be extremely sensitive to electrostatic discharge (ESD). After removing the board from the protective wrapper, place it component side up on a grounded, static-free surface. Do not slide the board over any surface.

Unpack the equipment from the shipping carton. Refer to the packing list and verify that all the items are present. Save the packing material for storing and reshipping of the equipment.

## 2.3 Installing the Serial Interface Modules

Configure the serial ports 3 and 4 for the required interface by installing the appropriate SIM. See [Table 1-1 on page 15](#) for a list of the serial port interface types.

Prior to installing the SIMs, set the jumpers on header J2 (for serial port 3) and header J3 (for serial port 4) for either DCE or DTE. Set the jumper to position:

- 1-2 if the SIM is for a DTE interface
- 2-3 if the SIM is for a DCE

*Figure 2-1 Serial Port Interface Jumper Setting*

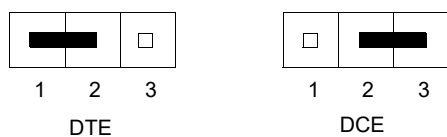

You must set the jumpers and install the SIMs prior to installing the MVME761 transition module in the system chassis. The SIMs plug into connector J1 (for serial port 3) or J12 (for serial port 4) on the MVME761 transition module.

Figure 2-2 SIM Configuration

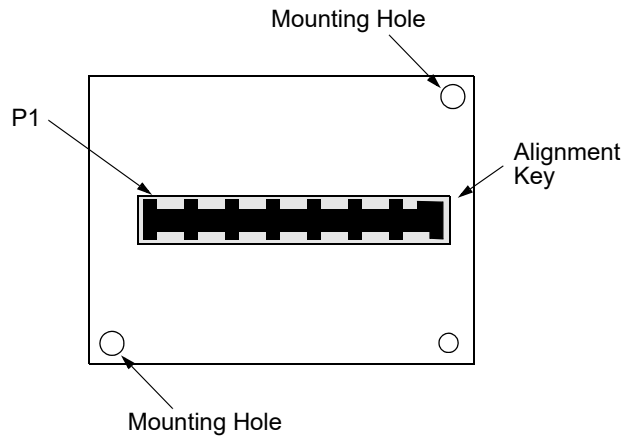

11637 9610

### Procedure

Install the SIMs on the MVME761 transition module per the following procedure:

1. Align the SIM so that P1 on the SIM lines up with the appropriate SIM connector (J1 for serial port 3 or J12 for serial port 4) on the transition module. Note the position of the alignment key on P1. See [Figure 2-2 on page 20](#).
2. Place the SIM onto the transition module SIM connector, making sure that the mounting holes also line up with the standoffs on the transition module as shown in [Figure 2-3 on page 21](#).
3. Gently press the top of the SIM to seat it on the transition module SIM connector. If the SIM does not seat with gentle pressure, re-check the alignment of the connectors.

Do not force the SIM onto the transition module.

- Secure the SIM to the transition module standoffs with the two Phillips-head screws provided. Do not over tighten the screws.

Figure 2-3 Installing the SIM

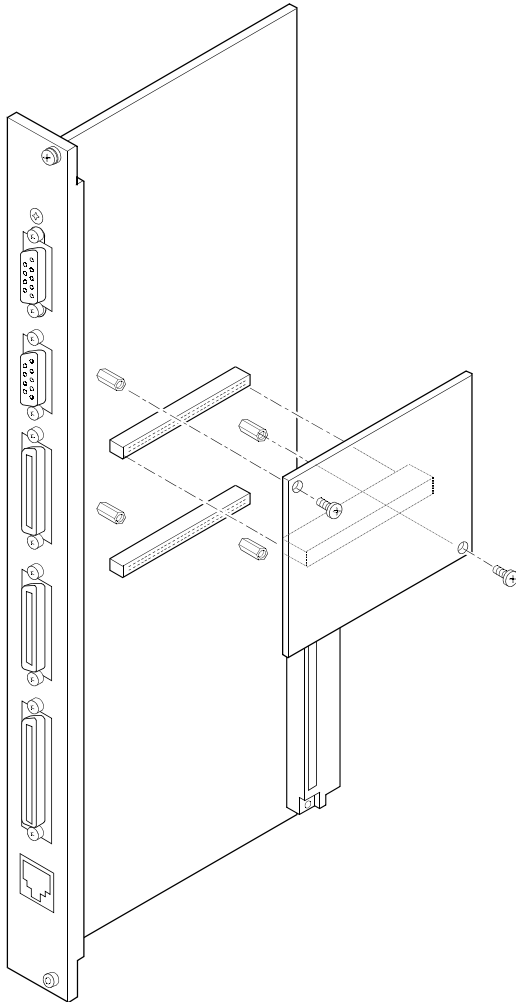

1911 9609

## 2.4 Installing the Transition Module and P2 Adapter

Install the MVME761 transition module and P2 adapter in the system chassis. The P2 adapter is required because the P2 connector on the transition module is not compatible with the P2 connector on the chassis backplane.

Use ESD protection



Emerson strongly recommends that you use an antistatic wrist strap and a conductive foam pad when installing or upgrading a system. Electronic components, such as disk drives, computer boards, and memory modules, can be extremely sensitive to electrostatic discharge (ESD). After removing the component from its protective wrapper or from the system, place the component flat on a grounded, static-free surface (and, in the case of a board, component side up). Do not slide the component over any surface.

If an ESD station is not available, you can avoid damage resulting from ESD by wearing an antistatic wrist strap (available at electronics stores) that is attached to an active electrical ground. Note that a system chassis may not be grounded if it is unplugged.

Install the MVME761-0x1 in the system chassis according to the procedures in this chapter.

### NOTICE

An MVME5100/MVME5500 module that is designed for use with an MVME712M Transition Module will be damaged if you use it with an MVME761-0x1 Transition Module.

Connecting modules while power is applied may result in damage to components on the module.



### WARNING

Dangerous voltages, capable of causing death, are present in this equipment. Use extreme caution when handling, testing, and adjusting.

Figure 2-4 Chassis Connections

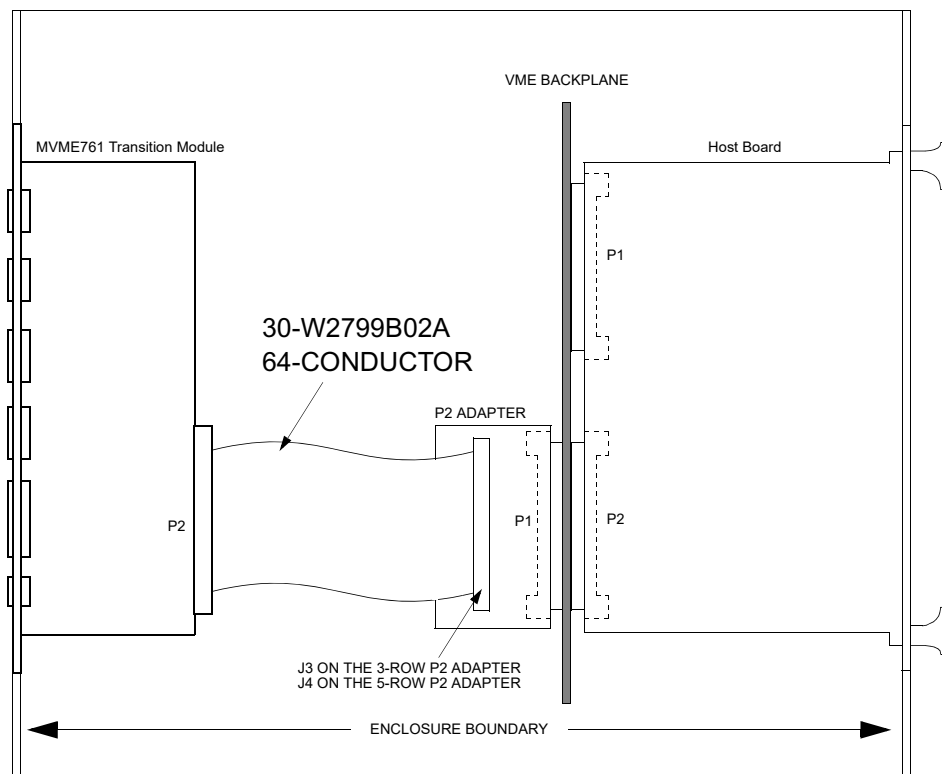

11654.00 9610

## Procedure

Follow these steps to configure, install, and cable the transition module.

1. Turn all equipment power OFF and disconnect the power cable from the AC power source.
2. Remove the chassis cover per the instructions in the equipment user's manual.
3. If the chassis has a rear card cage, remove the filler panel(s) from the appropriate card slot(s) at the rear of the chassis.
4. If necessary, move some of the other modules to allow space for the cables connected to the P2 adapter and the transition module.
5. Install the jumper on header J1 (on the 3-row P2 adapter or header J5 on the 5-row P2 adapter) if you are supporting SCSI devices.
6. Attach the P2 adapter, for either the 3-row or 5-row version, to the backplane connector that is directly in line with the P2 connector on the host VME module.
7. Orient pin 1 of the P2 adapter's connector with pin 1 of the backplane connector.

8. Attach the 64-conductor cable (furnished with the MVME761-0x1) to the P2 adapter (J3 on the 3-row version, J4 on the 5-row version). Be sure to orient cable pin 1 with connector pin 1.
9. Attach the 64-conductor cable to connector P2 on the transition module. Be sure to orient cable pin 1 with connector pin 1.
10. Insert the transition module into the chassis slot, and tighten the attaching screws. Make sure there is good contact with the transverse mounting rails in order to minimize RF emissions.
11. Install the chassis cover, making sure that cables are not pinched by the cover.
12. Connect the power cable to the AC power source.



## 3.1 Overview

This chapter provides information on MVME761 transition module and SIM circuitry, P2 signal multiplexing, and the configuration of the serial ports.

## 3.2 Circuitry

The MVME761 transition module and the Serial Interface Modules (SIMs) convert the TTL level signals to and from the MVME5100, and MVME5500 modules to the reception and transmission levels specified by the appropriate port interface standard.

The MVME761 transition module contains a small amount of “house keeping” circuitry. Bulk capacitors are on the power sources (+5Vdc, +12Vdc, and -12Vdc). Pullup resistors put the inputs to the host board in a known high even when no SIM is installed.

The block diagram for the MVME761 transition module is shown in Figure 3-1. The block diagram for the 3-row DIN backplane P2 adapter is shown in Figure 3-2. The block diagram for the 5-row DIN backplane P2 adapter is shown in Figure 3-3.

Figure 3-1 Transition Module Block Diagram

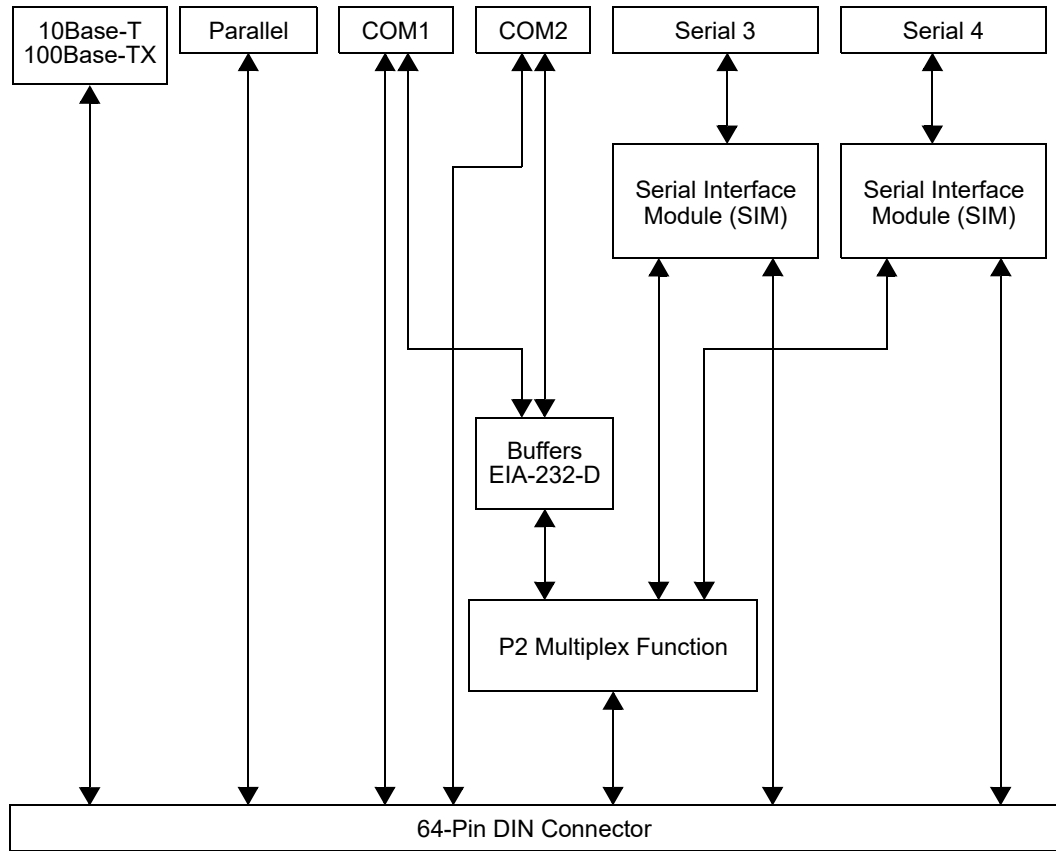

11638.00 961

Figure 3-2 3-Row DIN Backplane P2 Adapter Block Diagram

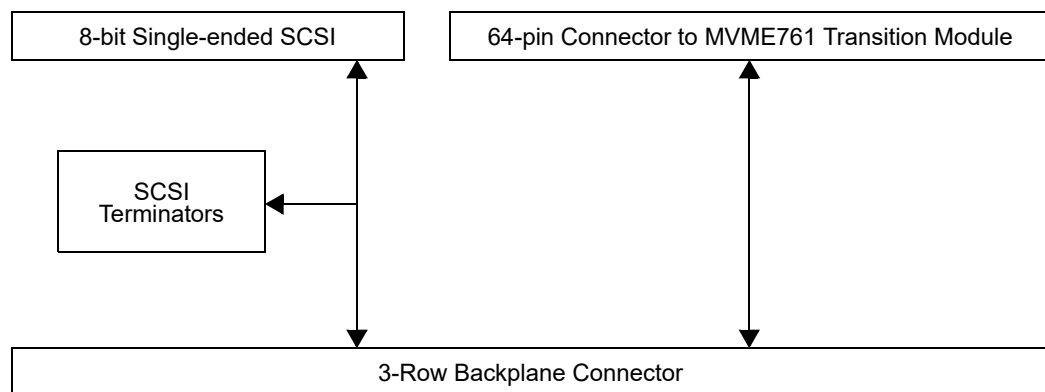

11639.00 961

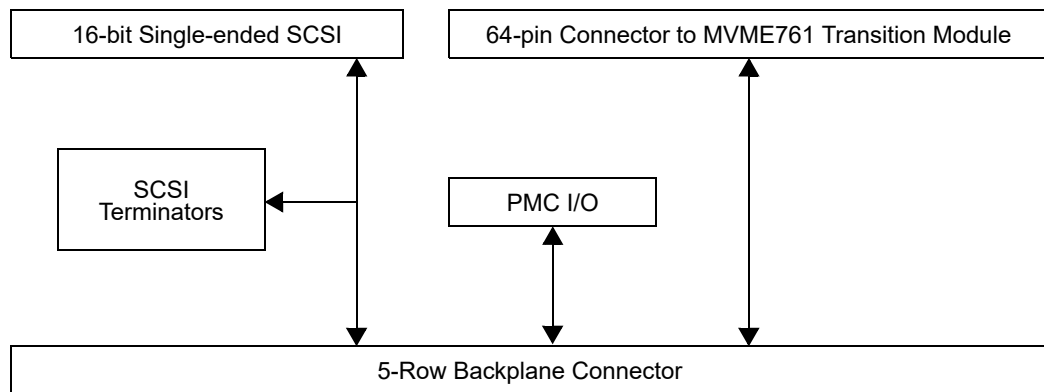
*Figure 3-3 5-Row DIN Backplane P2 Adapter Block Diagram*

11752.00 9703

### 3.3 P2 Signal Multiplexing (P2MX)

Because of a limited number of pins on the P2 connector, both the VME processor board and the MVME761 transition module multiplex and demultiplex some of the P2 signals. This function, called P2MX is transparent to the software and the user.

Four pins are used for the signal multiplexing:

- MXCLK
- MXSYNC#
- MXDO
- MXDI

Sixteen time slots are defined and allocated. The signal multiplexing sequences are listed in the following table..

Table 3-1 P2 signal multiplexing sequence

MXDO (from the MVME510x/MVME550x)		MXDI (from the MVME7616E)	
Time Slot	Signal Name	Time Slot	Signal Name
0	RTS3	0	CTS3
1	DTR3	1	DSR3/MID1
2	LLB3/MODSEL	2	DCD3
3	RLB3	3	TM3/MID0
4	RTS4	4	RI3
5	DTR4	5	CTS4
6	LLB4	6	DSR4/MID3
7	RLB4	7	DCD4
8	IDREQ#	8	TM4/MID2
9	DTR1	9	RI4
10	DTR2	10	RI1
11	Reserved	11	DSR1
12	Reserved	12	DCD1
13	Reserved	13	RI2
14	Reserved	14	DSR2
15	Reserved	15	DCD2

- MXCLK is the 10MHz bit clock for the time-multiplexed data lines, MXDO and MXDI.
- MXSYNC# is asserted for one bit time at Time Slot 15 by the MVME5100 and MVME5500. MXSYNC# is used by the MVME761 transition module to synchronize with the VME modules.
- MXDO is the time-multiplexed output line from the main board and MXDI is the time-multiplexed line from the MVME761 transition module. A 16-to-1 multiplexing scheme is used with a 10MHz bit rate.

MXSYNC# is clocked out using the falling edge of MXCLK and MDXO is clocked out with the rising edge of the MXCLK. MXDI is sampled at the rising edge of MXCLK (the transition module synchronizes MXDI with MXCLK's rising edge).

The timing relationships among MXCLK, MXSYNC#, MXDO, and MXDI are illustrated in the next figure.

Figure 3-4 Multiplex Signal Timing Chart

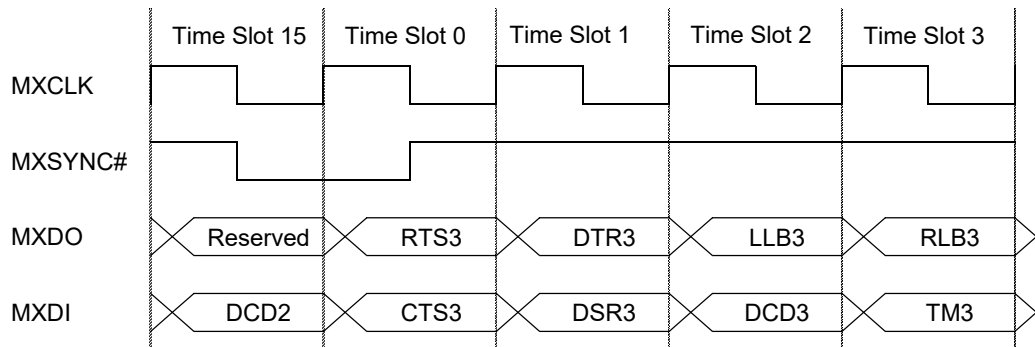

11640.00 9611

## 3.4 Serial Interface Module Circuitry

Each Serial Interface Module has a 60-pin connector that provides all signal and power connections to the MVME761 transition module.

### TTL-level signals

All TTL-level signals, with the exception of data and clocks, are active low. The pullup resistors on the MVME761 transition module drive all TTL inputs to the SIM to a known logic level.

### SIMs

The SIMs have surge suppression circuitry for all port signals going to the external connector. This consists of a series resistor and a dual 15V clamp diode to chassis ground. All series resistors are 100 ohms except on the EIA-530 balanced drives, which use 10 ohm series resistors.

EIA-232-D SIMs employ MC145406 ICs as line transmitters to convert the TTL output signals from the host VME module to EIA-232-D voltage levels. As line receivers, the MC145406 ICs convert the EIA-232-D input signals to TTL voltage levels which are sent to the VME module.

The MC145406 transceiver IC requires a series diode on the +12V supply and a clamp diode to logic ground on the -12V supply. The diodes are located on the transition module rather than on the SIM due to space limitations.

For all port interfaces, the SIMs support the transmitter signal element timing as either input or output signals.

### 3.5 COM1 and COM2 Asynchronous Serial Ports

The asynchronous serial port (COM1 and COM2) configuration is shown in the next figures..

Figure 3-5 EIA-574 DTE Port Configuration

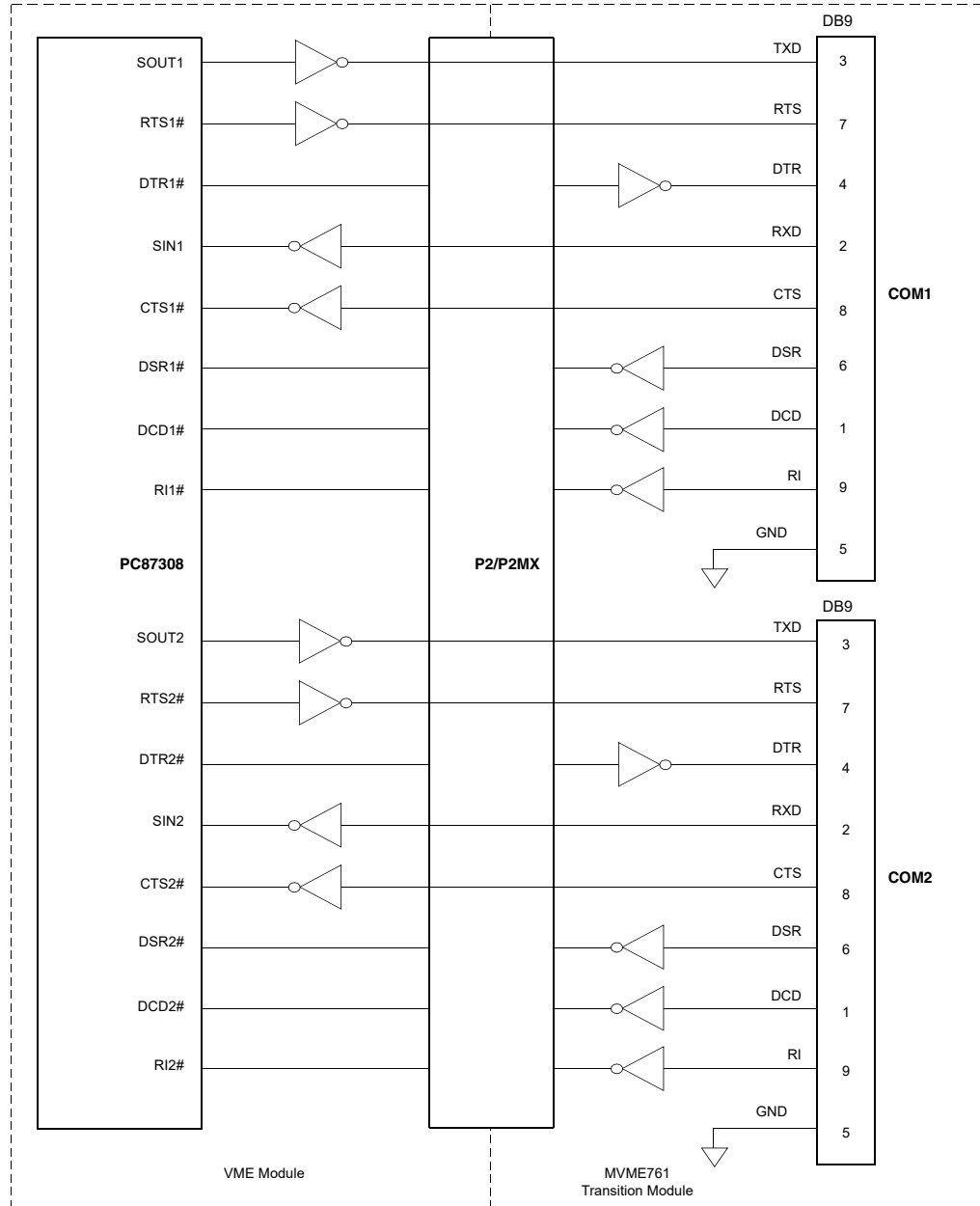

### 3.6 Asynchronous/Synchronous Serial Ports

The asynchronous/synchronous serial port (Port 3 and Port 4) interface configuration diagrams are on the following pages.

Figure 3-6 EIA232-DCE Copnfiguration Port 3

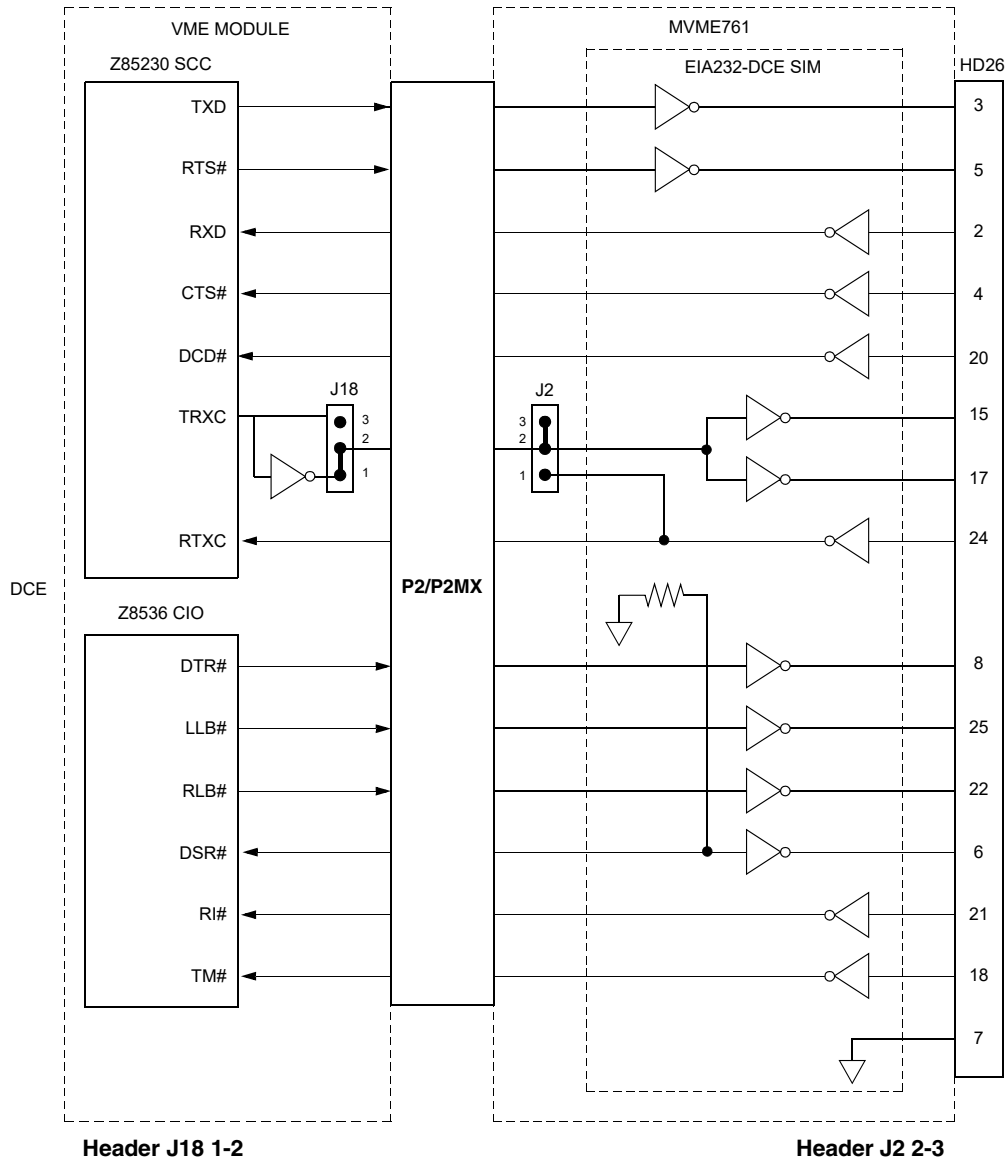

Figure 3-7 EIA232-DCE Configuration Port 4

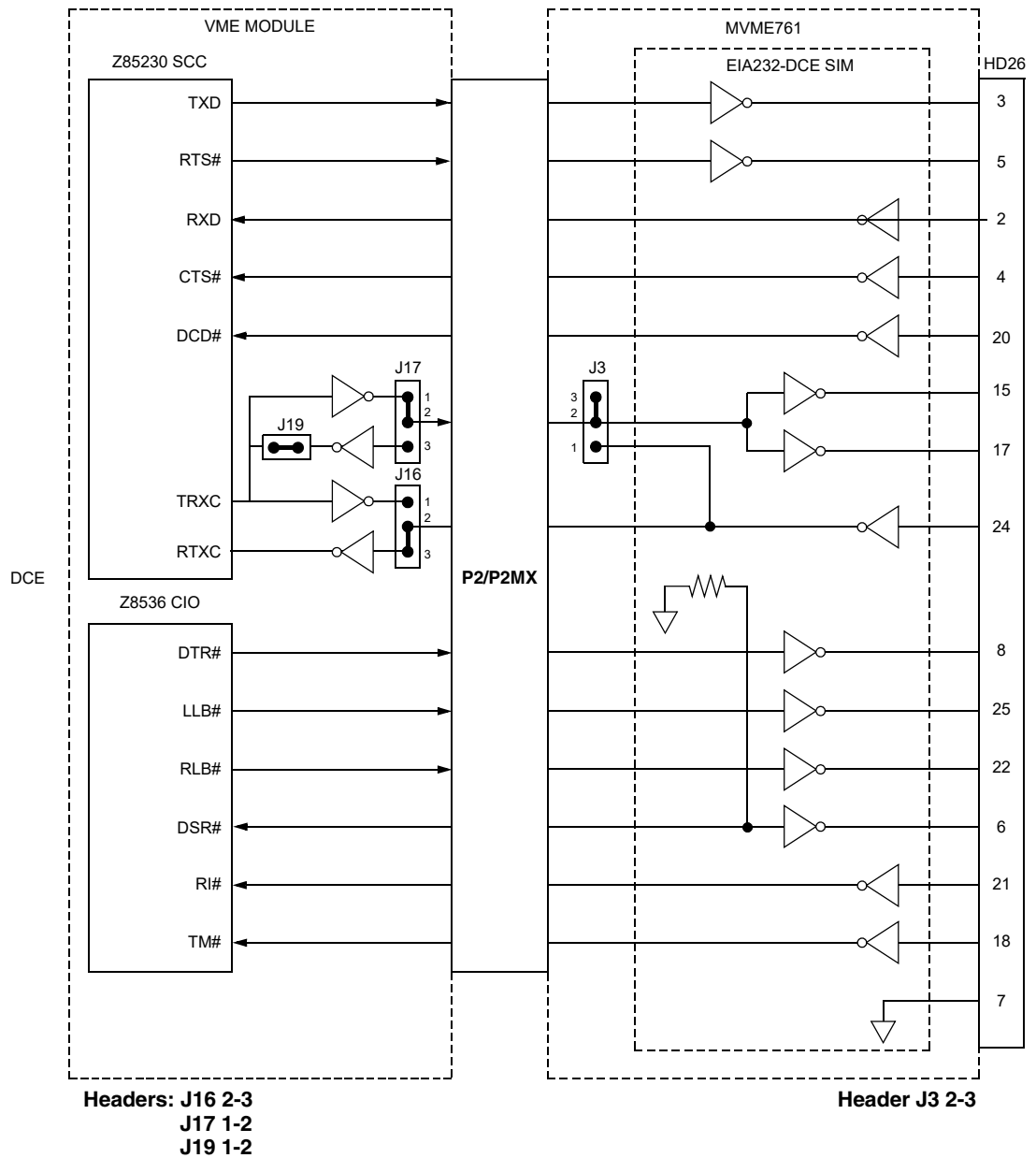



Figure 3-8 EIA232-DTE Configuration Port 3

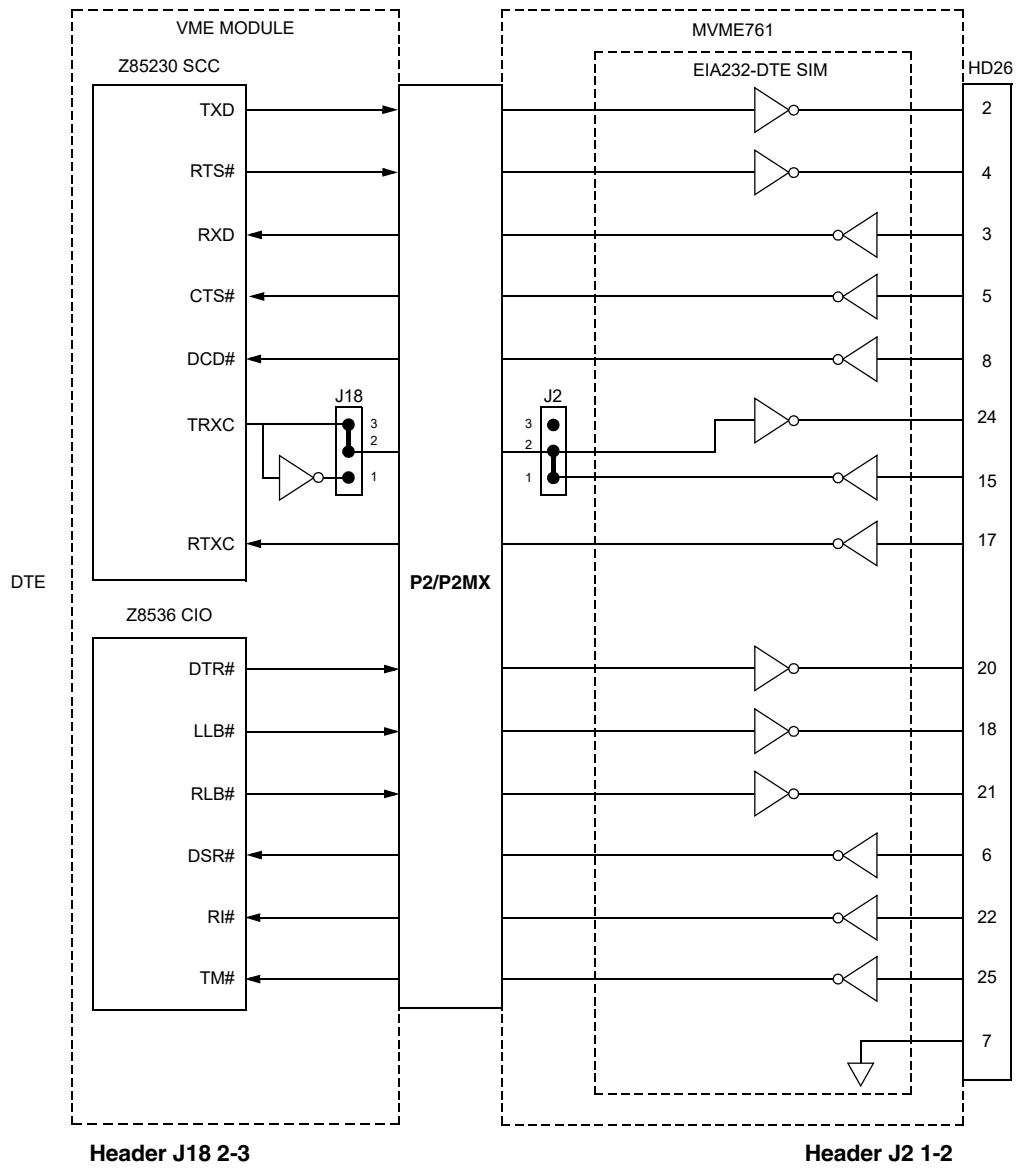
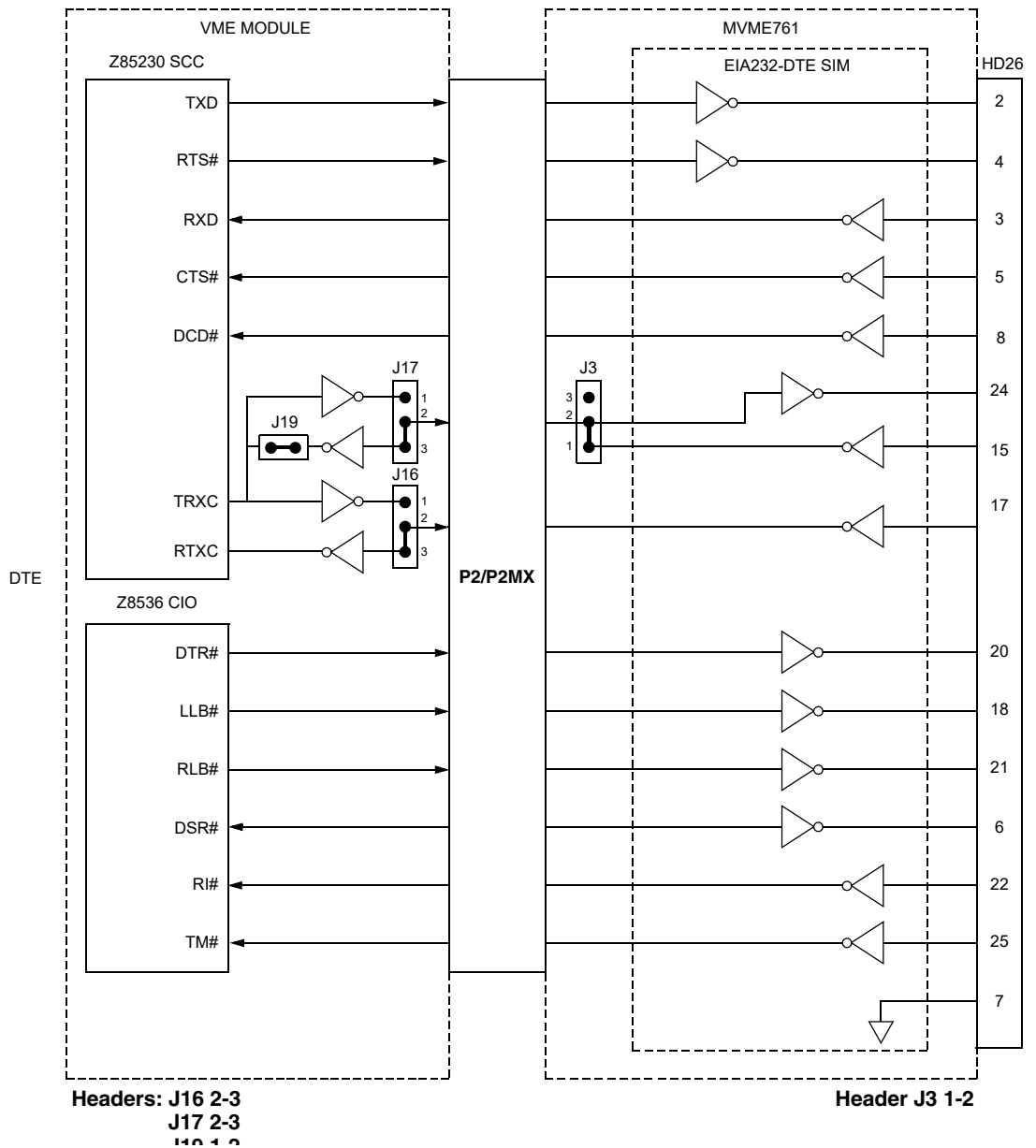

Figure 3-9 EIA232-DTE Configuration Port 4



## 4.1 Overview

This chapter provides the pin assignments for the P2 connector and front panel port connectors on the MVME761 transition module, as well as for the SCSI and PMC I/O connectors on the P2 adapters.

## 4.2 P2 Connector

Signaling and power from the host VMEmodules are received through connector P2, a 64-pin DIN connector. Because the P2 adapter reroutes some of the signals, connector P2 on the MVME761 transition module is not pin-for-pin compatible with connector P2 on the host VMEmodules.

The pin assignments and signal mnemonics for the MVME761 transition module P2 connector are listed in the following table.

Table 4-1 P2 Connector Pin Assignments

Row A Pins		Row C Pins	
Pin	Signal	Pin	Signal
1	C- (R- for RJ-45 J9)	1	C+ (R+ for RJ-45 J9)
2	T-	2	T+
3	R-	3	R+
4	+12VF	4	PRSTB#
5	GND	5	PRD0
6	PRD1	6	PRD2
7	PRD3	7	PRD4
8	PRD5	8	PRD6
9	PRD7	9	GND
10	PRACK#	10	GND
11	PRBSY	11	PRPE
12	PRSEL	12	INPRIME#
13	PRFAULT#	13	GND
14	AUTOFD#	14	GND
15	SELIN#	15	GND
16	TXD3	16	RXD3
17	RTXC3	17	TRXC3

Table 4-1 P2 Connector Pin Assignments (continued)

Row A Pins		Row C Pins	
Pin	Signal	Pin	Signal
18	GND	18	TXD1_232
19	GND	19	RXD1_232
20	GND	20	RTS1_232
21	CTS1	21	GND
22	TXD4	22	GND
23	RXD4	23	GND
24	RTXC4	24	GND
25	TRXC4	25	GND
26	No Connect	26	-12VF
27	MSYNC#	27	GND
28	MCLK	28	GND
29	TXD2_232	29	GND
30	RXD2_232	30	GND
31	RTS2_232	31	CTS2_232
32	MDO	32	MDI

### 4.3 Asynchronous Serial Port Connectors (J5/J6)

The interface for the asynchronous serial ports, COM1 and COM2, is provided with two standard DB9 connectors, J5 and J6. The connector shields for these ports are tied to chassis ground. The pin assignments and signal mnemonics for these connectors are listed in [Table 4-2](#).

Table 4-2 COM1 and COM2 Pin Assignments

Pin	Signal
1	DCD
2	RXD
3	TXD
4	DTR
5	GND
6	DSR
7	RTS
8	CTS
9	RI

## 4.4 Asynchronous/Synchronous serial Port connectors (J7/J8)

The interface for the asynchronous/synchronous serial ports 3 and 4 is provided by two HD-26 connectors, J7 and J8. The connector shields for these ports are tied to chassis ground.

The pin assignments and signal mnemonics for serial ports 3 and 4 are listed in the following tables.

*Table 4-3 Serial Port 3 Pin Assignments*

Pin	Signal	Pin	Signal
1	No Connect	14	SP3_P14
2	TXD3	15	TXCI3
3	RXD3	16	SP3_P16
4	RTS3	17	RXCI3
5	CTS3	18	LLB3
6	DSR3	19	SP3_P19
7	GND	20	DTR3
8	DCD3	21	RLB3
9	SP3_P9	22	RI3
10	SP3_P10	23	SP3_P23
11	SP3_P11	24	TXCO3
12	SP3_P12	25	TM3
13	SP3_P13	26	No Connect

*Table 4-4 Serial Port 4 Pin Assignments*

Pin	Signal	Pin	Signal
1	No Connect	14	SP4_P14
2	TXD4	15	TXCI4
3	RXD4	16	SP4_P16
4	RTS4	17	RXCI4
5	CTS4	18	LLB4
6	DSR4	19	SP4_P19
7	GND	20	DTR4
8	DCD4	21	RLB4
9	SP4_P9	22	RI4
10	SP4_P10	23	SP4_P23
11	SP4_P11	24	TXCO4
12	SP4_P12	25	TM4

Table 4-4 Serial Port 4 Pin Assignments (continued)

Pin	Signal	Pin	Signal
13	SP4_P13	26	No Connect

## 4.5 Parallel I/O Port Connector (J4)

The interface for the parallel port is a standard IEEE P1284-C, 36-pin connector, J4. The functionality of each signal depends on the mode of operation of this bidirectional Parallel Peripheral Interface. Refer to the IEEE P1284 D2.00 Standard for a complete description of each signal function. The connector shield is tied to chassis ground.

The pin assignments and signal mnemonics for this connector are listed in [Table 4-5](#).

Table 4-5 Parallel I/O Connector Pin Assignments

Pin	Signal	Signal	Pin
1	PRBSY	GND	19
2	PRSEL	GND	20
3	PRACK_	GND	21
4	PRFAULT_	GND	22
5	PRPE	GND	23
6	PRD0	GND	24
7	PRD1	GND	25
8	PRD2	GND	26
9	PRD3	GND	27
10	PRD4	GND	28
11	PRD5	GND	29
12	PRD6	GND	30
13	PRD7	GND	31
14	INPRIME_	GND	32
15	PRSTB_	GND	33
16	SELIN_	GND	34
17	AUTOFD_	GND	35
18	Pull-up	No Connect	36

## 4.6 Ethernet Connector (J9)

The 10Base-T/100Base-TX Ethernet interface is a RJ-45 connector, J9. The connector shield is tied to chassis ground. The pin assignments and signal mnemonics for this connector are listed in [Table 4-6](#).

*Table 4-6 10Base-T/100Base-TX Pin Assignments*

Pin	Signal
1	TD+
2	TD-
3	RD+
4	Terminated
5	Terminated
6	RD-
7	Terminated
8	Terminated

## 4.7 P2 Adapter Connectors

### 4.7.1 3-Row P2 Adapter (J2)

The 8-bit SCSI connector on the 3-row DIN backplane P2 Adapter is a 50-pin connector, J2. The pin assignments and signal mnemonics for this connector are listed in [Table 4-7](#).

*Table 4-7 8-bit SCSI Connector (3-Row P2 adapter)*

Pin	Signal	Signal	Pin
1	GND	TERMPWR	26
2	SDB0	GND	27
3	GND	GND	28
4	SDB1	GND	29
5	GND	GND	30
6	SDB2	GND	31
7	GND	ATN	32
8	SDB3	GND	33
9	GND	GND	34
10	SDB4	GND	35
11	GND	BSY	36
12	SDB5	GND	37

Table 4-7 8-bit SCSI Connector (3-Row P2 adapter) (continued)

Pin	Signal	Signal	Pin
13	GND	ACK	38
14	SDB6	GND	39
15	GND	RST	40
16	SDB7	GND	41
17	GND	MSG	42
18	DBP	GND	43
19	GND	SEL	44
20	GND	GND	45
21	GND	D/C	46
22	GND	GND	47
23	GND	REQ	48
24	GND	GND	49
25	No Connect	O/I	50

## 4.7.2 3-Row P2 Adapter (J3)

The pin assignments and signal mnemonics for this connector are listed in [Table 4-8](#).

Table 4-8 VME Connector (3-Row P2 adapter)

Pin	Signal	Signal	Pin
1	C+	DCD3	33
2	C-	DTR3	34
3	T+	TXD1	35
4	T-	GND	36
5	R+	RXD1	37
6	R-	GND	38
7	PRSTB_L	RTS1	39
8	+12VF	GND	40
9	PRD0	GND	41
10	GND	CTS1	42
11	PRD2	GND	43
12	PRD1	TXD4	44
13	PRD4	GND	45
14	PRD3	RXD4	46
15	PRD6	GND	47
16	PRD5	RTS4	48



Table 4-8 VME Connector (3-Row P2 adapter) (continued)

Pin	Signal	Signal	Pin
17	GND	GND	49
18	PRD7	TRXC4	50
19	GND	DTR4	51
20	PRACK_L	CTS4	52
21	PRPE	GND	53
22	PRBSY	DCD4	54
23	PRINIT_L	GND	55
24	PRSEL	RTXC4	56
25	GND	GND	57
26	PRFAULT_L	TXD2	58
27	GND	GND	59
28	TXD3	RXD2	60
29	GND	CTS2	61
30	RXD3	RTS2	62
31	CTS3	DCD2	63
32	RTS3	DTR2	64

### 4.7.3 5-Row P2 adapter (J1)

The 16-bit SCSI connector on the 5-row DIN backplane P2 Adapter is a 68-pin connector, J1. The pin assignments and signal mnemonics for this connector are listed in [Table 4-9](#).

Table 4-9 16-bit SCSI Connector (5-Row P2 adapter)

Pin	Signal	Signal	Pin
1	GND	SDB12	35
2	GND	SDB13	36
3	GND	SDB14	37
4	GND	SDB15	38
5	GND	DBP1	39
6	GND	SDB0	40
7	GND	SDB1	41
8	GND	SDB2	42
9	GND	SDB3	43
10	GND	SDB4	44
11	GND	SDB5	45
12	GND	SDB6	46

Table 4-9 16-bit SCSI Connector (5-Row P2 adapter) (continued)

Pin	Signal	Signal	Pin
13	GND	SDB7	47
14	GND	DBP0	48
15	GND	GND	49
16	GND	GND	50
17	TERMPWR	TERMPWR	51
18	TERMPWR	TERMPWR	52
19	No Connect	No Connect	53
20	GND	GND	54
21	GND	ATN	55
22	GND	GND	56
23	GND	BSY	57
24	GND	ACK	58
25	GND	RST	59
26	GND	MSG	60
27	GND	SEL	61
28	GND	D/C	62
29	GND	REQ	63
30	GND	O/I	64
31	GND	SDB8	65
32	GND	SDB9	66
33	GND	SDB10	67
34	GND	SDB11	68

#### 4.7.4 PMC I/O, 5-Row P2 Adapter (J3)

The PMC I/O connector on the 5-row DIN backplane P2 Adapter is a 64-pin connector, J3. The pin assignments and signal mnemonics for this connector are listed in [Table 4-10](#).

Table 4-10 PMC I/O Connector (5-Row P2 adapter)

Pin	Signal	Signal	Pin
1	GND	GND	33
2	PMCIO0	PMCIO16	34
3	GND	GND	35
4	PMCIO1	PMCIO17	36
5	GND	GND	37
6	PMCIO2	PMCIO18	38

Table 4-10 PMC I/O Connector (5-Row P2 adapter) (continued)

Pin	Signal	Signal	Pin
7	GND	GND	39
8	PMCIO3	PMCIO19	40
9	GND	GND	41
10	PMCIO4	PMCIO20	42
11	GND	GND	43
12	PMCIO5	PMCIO21	44
13	GND	GND	45
14	PMCIO6	PMCIO22	46
15	GND	GND	47
16	PMCIO7	PMCIO23	48
17	GND	GND	49
18	PMCIO8	PMCIO24	50
19	GND	GND	51
20	PMCIO9	PMCIO25	52
21	GND	GND	53
22	PMCIO10	PMCIO26	54
23	GND	GND	55
24	PMCIO11	PMCIO27	56
25	GND	GND	57
26	PMCIO12	PMCIO28	58
27	GND	GND	59
28	PMCIO13	PMCIO29	60
29	GND	GND	61
30	PMCIO14	PMCIO30	62
31	GND	GND	63
32	PMCIO15	PMCIO31	64

#### 4.7.5 5-Row P2 adapter (J4)

The J4 connector on the 5-row P2 adapter is a VME, 64-pin male connector used for output to the P2 connector on the MVME761.

Table 4-11 VME Connector (3-Row P2 adapter)

Pin	Signal	Signal	Pin
1	C+	DCD3	33
2	C-	DTR3	34

Table 4-11 VME Connector (3-Row P2 adapter) (continued)

Pin	Signal	Signal	Pin
3	T+	TXD1	35
4	T-	GND	36
5	R+	RXD1	37
6	R-	GND	38
7	PRSTB_L	RTS1	39
8	+12VF	GND	40
9	PRD0	GND	41
10	GND	CTS1	42
11	PRD2	GND	43
12	PRD1	TXD4	44
13	PRD4	GND	45
14	PRD3	RXD4	46
15	PRD6	GND	47
16	PRD5	RTS4	48
17	GND	GND	49
18	PRD7	TRXC4	50
19	GND	DTR4	51
20	PRACK_L	CTS4	52
21	PRPE	GND	53
22	PRBSY	DCD4	54
23	PRINIT_L	GND	55
24	PRSEL	RTXC4	56
25	GND	GND	57
26	PRFAULT_L	TXD2	58
27	GND	GND	59
28	TXD3	RXD2	60
29	GND	CTS2	61
30	RXD3	RTS2	62
31	CTS3	DCD2	63
32	RTS3	DTR2	64

## Numerics

100Base-TX [13](#), [39](#)

10Base-T [13](#), [39](#)

## A

asynchronous serial port  
signals [36](#)

asynchronous/synchronous serial port  
configurations [31](#)  
signals [37](#)

## B

backplane connector [15](#), [16](#)

## C

cables

64-line flat ribbon [17](#)

EIA-232 [17](#)

modem [17](#)

P2 adapter [15](#)

printer [17](#)

shielded [18](#)

circuitry

MVME761 [25](#)

SIMs [29](#)

Class A equipment [18](#)

COM1/COM2 pin assignments [36](#)

connectors [16](#)

MVME761

J4, parallel port [38](#)

J5/J6, serial ports [36](#)

J7/J8, serial ports [37](#)

J9, Ethernet [39](#)

P2 [35](#)

RJ-45 [39](#)

P2 adapter 3-row

J2, SCSI connector [39](#)

J3, VME [40](#)

P2 adapter 5-row

J1, SCSI [41](#)

J3, PMC I/O [42](#)

J4, VME [43](#)

SIM [29](#)

cooling requirements [18](#)

## D

DIN connector [35](#)

## E

EIA-232-D, circuitry [29](#)

EMI,ESD [13](#)

ESD precautions [22](#)

Ethernet [13](#)

Ethernet pin assignments [39](#)

Ethernet signals [39](#)

## F

FCC compliance [18](#)

features [13](#)

## G

grounding [18](#)

## I

I/O controllers [13](#)

installation

MVME761 [22](#)

P2 adapter [22](#)

SIMs [19](#)

## J

jumper settings, SCSI devices [23](#)

## L

line transmitters [29](#)

## M

model numbers [9](#)

multiplexing function [13](#)

MVME761

board size [18](#)

cables [17](#)

circuitry [25](#)

connectors [16](#), [35](#)

description [13](#)

installation [22](#)

pin assignments (P2) [35](#)

specifications [18](#)

## O

operating temperature [18](#)

output to P2 connector (MVME761) [40](#), [43](#)

## P

P2 Adapter [13](#)

P2 adapter connectors [39](#)

P2 adapter, 3-row [15](#)

P2 adapter, 5-row [16](#)

P2 adapter, connectors [16](#)

P2 adapter, installation [22](#)

P2 adapter, pin assignments [39](#)

parallel port pin assignments [38](#)

---

parallel port signals [38](#)  
part numbers  
    P2 adapter, 3-row [15](#)  
    P2 adapter, 5-row [16](#)  
    SIM [14](#)  
pin assignments [35](#)  
    Ethernet connector J9 [39](#)  
    P2 connector (MVME761) [35](#)  
    parallel port J4 (MVME761) [38](#)  
    PMC I/O, J3 (P2 adapter 5-row) [42](#)  
    SCSI connector J2 (P2 adapter 3-row) [39](#)  
    SCSI, J1 (P2 adapter 5-row) [41](#)  
    serial port (MVME761) [36](#)  
    serial port 3/4 (MVME761) [37](#)  
    VME connector J4 (P2 adapter 5-row) [43](#)  
    VME connector, J3 (P2 adapter 3-row) [40](#)  
pin compatibility for P2 connectors [35](#)  
PMC I/O [16](#)  
PMC I/O connector (P2 adapter 5-row) [42](#)  
port configurations [30](#)  
port connectors, location [16](#)  
port interfaces [14](#)  
port signals [36](#), [38](#)  
power requirements [18](#)  
power source [25](#)  
procedures  
    cabling the transition module [24](#)  
    installing SIMs [20](#)  
product description [9](#), [13](#)

## R

relative humidity [18](#)  
RF emissions [18](#)  
running SCSI devices [15](#)

## S

SCSI connector [41](#)  
SCSI connector pin assignments [39](#), [41](#)  
SCSI connector, 3-row (P2 adapter) [39](#)  
SCSI connector, 5-row (P2 adapter) [41](#)  
SCSI devices [15](#)  
SCSI port [15](#)  
Serial Interface Module, see SIM  
serial port  
    configurations [30](#), [31](#)–??  
    signals [36](#)  
serial port 3 pin assignments [37](#)  
serial port 4 pin assignments [37](#)  
serial ports [13](#), [14](#), [25](#)  
series resistors [29](#)  
signal multiplexing [25](#)  
signals, TTL-level [29](#)  
SIM [13](#)  
    circuitry [25](#), [29](#)  
    description [14](#)  
    installation [19](#)  
    part numbers [14](#)  
    specifications [18](#)  
    storage temperature [18](#)  
    surge suppression [29](#)

## T

temperature [18](#)  
TTL-level signals [29](#)

## V

variants [9](#)  
VMEmodules, supported [13](#)