

**MVME5500
Single-Board Computer**

**Programmer's Reference
Guide**

V5500A/PG2

October 2003 Edition



Ehlbeek 15a
30938 Burgwedel
fon 05139-9980-0
fax 05139-9980-49

www.powerbridge.de
info@powerbridge.de

© Copyright 2003 Motorola Inc.

All rights reserved.

Printed in the United States of America.

Motorola and the stylized M logo are trademarks of Motorola, Inc., registered in the U.S. Patent and Trademark Office.

All other product or service names mentioned in this document are the property of their respective owners.

Safety Summary

The following general safety precautions must be observed during all phases of operation, service, and repair of this equipment. Failure to comply with these precautions or with specific warnings elsewhere in this manual could result in personal injury or damage to the equipment.

The safety precautions listed below represent warnings of certain dangers of which Motorola is aware. You, as the user of the product, should follow these warnings and all other safety precautions necessary for the safe operation of the equipment in your operating environment.

Ground the Instrument.

To minimize shock hazard, the equipment chassis and enclosure must be connected to an electrical ground. If the equipment is supplied with a three-conductor AC power cable, the power cable must be plugged into an approved three-contact electrical outlet, with the grounding wire (green/yellow) reliably connected to an electrical ground (safety ground) at the power outlet. The power jack and mating plug of the power cable meet International Electrotechnical Commission (IEC) safety standards and local electrical regulatory codes.

Do Not Operate in an Explosive Atmosphere.

Do not operate the equipment in any explosive atmosphere such as in the presence of flammable gases or fumes. Operation of any electrical equipment in such an environment could result in an explosion and cause injury or damage.

Keep Away From Live Circuits Inside the Equipment.

Operating personnel must not remove equipment covers. Only Factory Authorized Service Personnel or other qualified service personnel may remove equipment covers for internal subassembly or component replacement or any internal adjustment. Service personnel should not replace components with power cable connected. Under certain conditions, dangerous voltages may exist even with the power cable removed. To avoid injuries, such personnel should always disconnect power and discharge circuits before touching components.

Use Caution When Exposing or Handling a CRT.

Breakage of a Cathode-Ray Tube (CRT) causes a high-velocity scattering of glass fragments (implosion). To prevent CRT implosion, do not handle the CRT and avoid rough handling or jarring of the equipment. Handling of a CRT should be done only by qualified service personnel using approved safety mask and gloves.

Do Not Substitute Parts or Modify Equipment.

Do not install substitute parts or perform any unauthorized modification of the equipment. Contact your local Motorola representative for service and repair to ensure that all safety features are maintained.

Observe Warnings in Manual.

Warnings, such as the example below, precede potentially dangerous procedures throughout this manual. Instructions contained in the warnings must be followed. You should also employ all other safety precautions which you deem necessary for the operation of the equipment in your operating environment.



To prevent serious injury or death from dangerous voltages, use extreme caution when handling, testing, and adjusting this equipment and its components.

Flammability

All Motorola PWBs (printed wiring boards) are manufactured with a flammability rating of 94V-0 by UL-recognized manufacturers.

EMI Caution



This equipment generates, uses and can radiate electromagnetic energy. It may cause or be susceptible to electromagnetic interference (EMI) if not installed and used with adequate EMI protection.

Lithium Battery Caution

This product contains a lithium battery to power the clock and calendar circuitry.



Danger of explosion if battery is replaced incorrectly. Replace battery only with the same or equivalent type recommended by the equipment manufacturer. Dispose of used batteries according to the manufacturer's instructions.



Il y a danger d'explosion s'il y a remplacement incorrect de la batterie. Remplacer uniquement avec une batterie du même type ou d'un type équivalent recommandé par le constructeur. Mettre au rebut les batteries usagées conformément aux instructions du fabricant.



Explosionsgefahr bei unsachgemäßem Austausch der Batterie. Ersatz nur durch denselben oder einen vom Hersteller empfohlenen Typ. Entsorgung gebrauchter Batterien nach Angaben des Herstellers.

CE Notice (European Community)



This is a Class A product. In a domestic environment, this product may cause radio interference, in which case the user may be required to take adequate measures.

Motorola Computer Group products with the CE marking comply with the EMC Directive (89/336/EEC). Compliance with this directive implies conformity to the following European Norms:

EN55022 “Limits and Methods of Measurement of Radio Interference Characteristics of Information Technology Equipment”; this product tested to Equipment Class A

EN55024 “Information technology equipment—Immunity characteristics—Limits and methods of measurement”

Board products are tested in a representative system to show compliance with the above mentioned requirements. A proper installation in a CE-marked system will maintain the required EMC performance.

In accordance with European Community directives, a “Declaration of Conformity” has been made and is available on request. Please contact your sales representative.

Notice

While reasonable efforts have been made to assure the accuracy of this document, Motorola, Inc. assumes no liability resulting from any omissions in this document, or from the use of the information obtained therein. Motorola reserves the right to revise this document and to make changes from time to time in the content hereof without obligation of Motorola to notify any person of such revision or changes.

Electronic versions of this material may be read online, downloaded for personal use, or referenced in another document as a URL to the Motorola Computer Group Web site. The text itself may not be published commercially in print or electronic form, edited, translated, or otherwise altered without the permission of Motorola, Inc.

It is possible that this publication may contain reference to or information about Motorola products (machines and programs), programming, or services that are not available in your country. Such references or information must not be construed to mean that Motorola intends to announce such Motorola products, programming, or services in your country.

Limited and Restricted Rights Legend

If the documentation contained herein is supplied, directly or indirectly, to the U.S. Government, the following notice shall apply unless otherwise agreed to in writing by Motorola, Inc.

Use, duplication, or disclosure by the Government is subject to restrictions as set forth in subparagraph (b)(3) of the Rights in Technical Data clause at DFARS 252.227-7013 (Nov. 1995) and of the Rights in Noncommercial Computer Software and Documentation clause at DFARS 252.227-7014 (Jun. 1995).

Motorola, Inc.
Computer Group
2900 South Diablo Way
Tempe, Arizona 85282

Contents

About This Guide

Summary of Changes	xiii
Overview of Contents	xiii
Comments and Suggestions	xiv
Conventions Used in This Manual	xiv

CHAPTER 1 Board Description and Memory Maps

Introduction	1-1
Overview	1-1
Memory Maps	1-5
Default Processor Memory Map	1-5
MOTLoad's Processor Memory Map	1-6
Default PCI Memory Map	1-7
MOTLoad's PCI Memory Maps	1-9
PCI I/O Space Maps	1-9
System I/O Memory Map	1-10
System Status Register 1	1-11
System Status Register 2	1-13
System Status Register 3	1-15
Presence Detect Register	1-16
Configuration Header/Switch Register (S1)	1-17
Time Base Enable Register	1-18
Geographical Address Register (S2)	1-18
COM1 & COM2 Universal Asynchronous Receiver/Transmitter (UART) ...	1-20
Real-Time Clock and NVRAM	1-20
ISA Local Resource Bus	1-20

CHAPTER 2 Programming Details

Introduction	2-1
PCI Configuration Space and IDSEL Mapping	2-1
Interrupt Controller	2-3
Two-Wire Serial Interface	2-5
GT-64260B Initialization	2-7
GT-64260B GPP Configuration	2-7

GT-64260B Reset Configuration	2-9
GT-64260B Device Controller Bank Assignments	2-11
System Clock Generators	2-13
VPD and User Configuration EEPROMs	2-14
Temperature Sensor	2-14
Flash Memory	2-14
PCI Arbitration Assignments	2-14
Other Software Considerations	2-15
CPU Bus Mode	2-15
Processor Type Identification	2-16
Processor PLL Configuration	2-16
L1, L2, L3 Cache	2-16

APPENDIX A Vital Product Data

Flash Memory Configuration Data	A-1
L3 Cache Configuration Data	A-3

APPENDIX B Related Documentation

Motorola Computer Group Documents	B-1
Manufacturers' Documents	B-2
Related Specifications	B-5

List of Figures

Figure 1-1. MVME5500 Block Diagram 1-4

List of Tables

Table 1-1. MVME5500 Features Summary	1-2
Table 1-2. Default Processor Memory Map	1-5
Table 1-3. MOTLoad's Processor Memory Map	1-6
Table 1-4. Default PCI Memory Map	1-7
Table 1-5. MOTLoad's PCI 0 Domain Memory Map	1-9
Table 1-6. MOTLoad's PCI 1 Domain Memory Map	1-9
Table 1-7. PCI 0 Domain I/O Map	1-9
Table 1-8. PCI 1 Domain I/O Map	1-10
Table 1-9. Device Bank 1 I/O Memory Map	1-10
Table 1-10. System Status Register 1	1-11
Table 1-11. System Status Register 2	1-13
Table 1-12. System Status Register 3	1-15
Table 1-13. Presence Detect Register	1-16
Table 1-14. Configuration Header/Switch Register	1-17
Table 1-15. TBEN Register	1-18
Table 1-16. Geographical Address Register	1-19
Table 2-1. IDSEL Mapping for PCI Devices	2-2
Table 2-2. GT-64260B External GPP Interrupt Assignments	2-4
Table 2-3. I2C Bus Device Addressing	2-6
Table 2-4. GT-64260B GPP Pin Function Assignments	2-7
Table 2-5. GT-64260B Power-Up Configuration Settings	2-10
Table 2-6. Device Bank Assignments	2-12
Table 2-7. Device Bank Timing Parameters	2-12
Table 2-8. PCI Arbiter Assignments	2-15
Table 2-9. Processor L3CR Register Assignments	2-16
Table A-1. Flash 0 Memory Configuration Data	A-1
Table A-2. Flash 1 Memory Configuration Data	A-2
Table A-3. L3 Cache Configuration Data	A-3
Table B-1. Motorola Computer Group Documents	B-1
Table B-2. Manufacturers' Documents	B-2
Table B-3. Related Specifications	B-5

About This Guide

The *MVME5500 Single-Board Computer Programmer's Reference Guide* provides general programming information, including memory maps, interrupts, and register data for the MVME5500 family of boards. This document should be used by anyone who wants general, as well as technical information about the MVME5500 products.

As of the printing date of this manual, the MVME5500 supports the models listed below.

Model Number	Description
MVME5500-0161	1 GHz MPC7455 processor, 512MB SDRAM, Scanbe handles
MVME5500-0163	1 GHz MPC7455 processor, 512MB SDRAM, IEEE handles

Summary of Changes

This is the second edition of the *Programmer's Reference Manual*. It supersedes the August 2003 edition and incorporates the following changes.

Date	Changes
October 2003	Corrected the PCI 0 and 1 domain memory space sizes in Table 1-3 on page 1-6 .

Overview of Contents

This manual is divided into the following chapters and appendices:

[Chapter 1, *Board Description and Memory Maps*](#), provides a brief product description and a block diagram. The remainder of the chapter provides information on memory maps and system and configuration registers.

[Chapter 2, *Programming Details*](#), provides additional programming information including IDSEL mapping, interrupt assignments for the GT-64260B system processor, two-wire serial interface addressing, and other device and system considerations.

[Appendix A, *Vital Product Data*](#), provides a listing of vital product data (VPD) related to this product.

[Appendix B, *Related Documentation*](#), provides a listing of related Motorola manuals, vendor documentation, and industry specifications.

Comments and Suggestions

Motorola welcomes and appreciates your comments on its documentation. We want to know what you think about our manuals and how we can make them better. Mail comments to:

Motorola Computer Group
Reader Comments DW164
2900 S. Diablo Way
Tempe, Arizona 85282

You can also submit comments to the following e-mail address:
reader-comments@mcg.mot.com

In all your correspondence, please list your name, position, and company. Be sure to include the title and part number of the manual and tell how you used it. Then tell us your feelings about its strengths and weaknesses and any recommendations for improvements.

Conventions Used in This Manual

The following typographical conventions are used in this document:

bold

is used for user input that you type just as it appears; it is also used for commands, options and arguments to commands, and names of programs, directories and files.

italic

is used for names of variables to which you assign values, for function parameters, and for structure names and fields. Italic is also used for comments in screen displays and examples, and to introduce new terms.

`courier`

is used for system output (for example, screen displays, reports), examples, and system prompts.

<Enter>, **<Return>** or **<CR>**

represents the carriage return or Enter key.

Ctrl

represents the Control key. Execute control characters by pressing the Ctrl key and the letter simultaneously, for example, Ctrl-d.

Introduction

This chapter briefly describes the board level hardware features of the MVME5500 single-board computer, including a table of features and a block diagram. The remainder of the chapter provides memory map information including a default memory map, MOTLoad's processor memory map, a default PCI memory map, MOTLoad's PCI memory map, a PCI I/O memory map, and system I/O memory maps.

Programmable registers in the GT-64260B system controller are documented in publication MV-S100414-00 Rev A, which is obtainable from Marvell Technologies, Ltd. Refer to [Appendix B, Related Documentation](#) for more information.

Overview

The MVME5500 is a single-board computer based on the PowerPC MPC7455 processor and the Marvell GT-64260B host bridge with a dual PCI interface and memory controller. On-board payload includes two PMC slots, two SDRAM banks, an expansion connector for two additional banks of SDRAM, 8MB boot Flash ROM, one 10/100/1000 Ethernet port, one 10/100 Ethernet port, 32MB expansion Flash ROM, two serial ports, and an NVRAM and real-time clock.

The following table lists the features of the MVME5500.

Table 1-1. MVME5500 Features Summary

Feature	Description
Processor	<ul style="list-style-type: none"> – Single 1 GHz MPC7455 processor – Bus clock frequency at 133 MHz
L3 Cache	<ul style="list-style-type: none"> – 2MB using DDR SRAM – Bus clock frequency at 200 MHz
Flash	<ul style="list-style-type: none"> – 8MB Flash soldered on board – 32MB expansion Flash soldered on board
System Memory	<ul style="list-style-type: none"> – Two banks on-board for 512MB using 256Mb devices – Expansion connector for a mezzanine board with two banks for 512MB using 256Mb devices – Double-bit-error detect, single-bit-error correct across 72 bits – Bus clock frequency at 133 MHz
Memory Controller	<ul style="list-style-type: none"> – Provided by GT-64260B – Supports one to four banks of SDRAM at up to 1GB per bank
Processor Host Bridge	<ul style="list-style-type: none"> – Provided by GT-64260B – Supports MPX mode or 60x mode
PCI Interfaces	<ul style="list-style-type: none"> – Provided by GT-64260B – Two independent 64-bit interfaces, one compliant to PCI spec rev 2.1 (Bus 0.0) and the other compliant to PCI spec rev 2.2 (Bus 1.0) – Bus clock frequency at 66 MHz
	<ul style="list-style-type: none"> – Provided by the HiNT PCI 6154 secondary interface – One 64-bit interface, compliant to PCI spec rev 2.1 (Bus 0.1) – Bus clock frequency at 33 MHz
Interrupt Controller	<ul style="list-style-type: none"> – Provided by GT-64260B – Interrupt sources internal to GT-64260B – Up to 32 external interrupt inputs – Up to seven interrupt outputs
Counters/Timers	<ul style="list-style-type: none"> – Eight 32-bit counters/timers in GT-64260B

Table 1-1. MVME5500 Features Summary (continued)

Feature	Description
I2C	<ul style="list-style-type: none"> – Provided by GT-64260B – Master or slave capable – On-board serial EEPROMs for VPD, SPD, GT-64260B init, and user data storage
NVRAM	– 32KB provided by MK48T37
Real Time Clock	– Provided by MK48T37
Watchdog Timers	<ul style="list-style-type: none"> – One in GT-64260B – One in MK48T37 – Each watchdog timer can generate interrupt or reset, software selectable
On-board Peripheral Support	<ul style="list-style-type: none"> – One 10/100/1000BaseT Ethernet interface, one 10/100BaseT Ethernet interface – Dual 16C550 compatible UARTs
PCI Mezzanine Cards	– Two PMC sites (one shared with the expansion memory and has IPMC capability)
PCI Expansion	– One expansion connector for interface to PMCspan
Miscellaneous	<ul style="list-style-type: none"> – Reset/Abort switch – Front panel status indicators, Run and Board Fail
Form Factor	– Standard VME

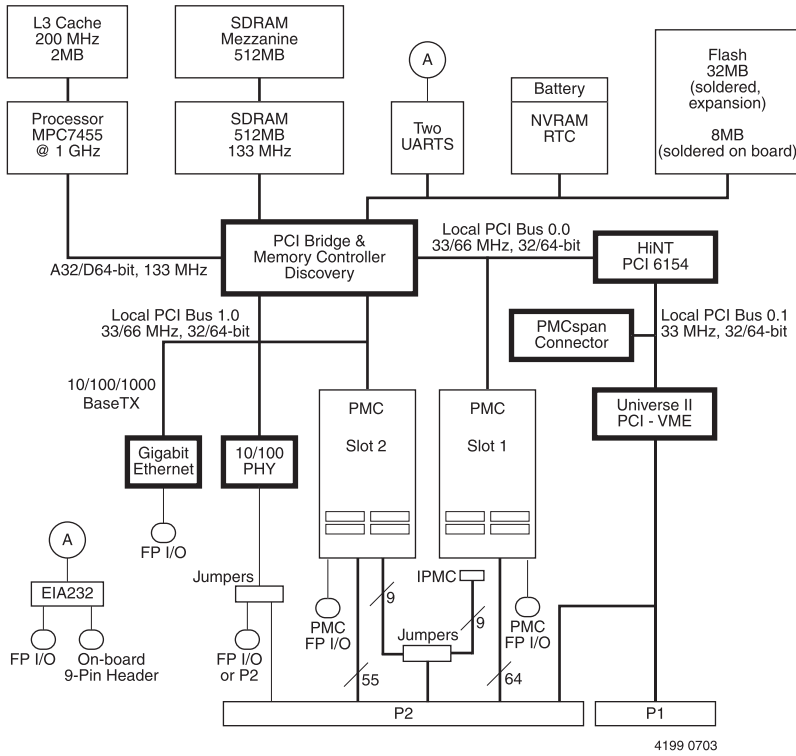

Figure 1-1. MVME5500 Block Diagram

Memory Maps

Default Processor Memory Map

When power is first applied or a hard reset has occurred, the GT-64260B has a default address map. Table 1-2 shows the default processor memory map.

Table 1-2. Default Processor Memory Map

Processor Address		Size	Definition	Notes
Start	End			
0000 0000	007F FFFF	8MB	SDRAM Bank 0	
0080 0000	00FF FFFF	8MB	SDRAM Bank 1	
0100 0000	017F FFFF	8MB	SDRAM Bank 2	
0180 0000	01FF FFFF	8MB	SDRAM Bank 3	
0200 0000	0FFF FFFF	224MB	Unassigned	
1000 0000	11FF FFFF	32MB	PCI Bus 0 I/O Space	
1200 0000	13FF FFFF	32MB	PCI Bus 0 Memory Space 0	
1400 0000	1BFF FFFF	128MB	Unassigned	
1C00 0000	1C7F FFFF	8MB	Device Port CS0	
1C80 0000	1CFF FFFF	8MB	Device Port CS1	
1D00 0000	1DFF FFFF	16MB	Device Port CS2	
1E00 0000	1FFF FFFF	32MB	Unassigned	
2000 0000	21FF FFFF	32MB	PCI Bus 1 I/O	
2200 0000	23FF FFFF	32MB	PCI Bus 1 Memory Space 0	
2400 0000	25FF FFFF	32MB	PCI Bus 1 Memory Space 1	
2600 0000	27FF FFFF	32MB	PCI Bus 1 Memory Space 2	
2800 0000	29FF FFFF	32MB	PCI Bus 1 Memory Space 3	
2A00 0000	F0FF FFFF	3184MB	Unassigned	

Table 1-2. Default Processor Memory Map (continued)

Processor Address		Size	Definition	Notes
Start	End			
F100 0000	F100 FFFF	64KB	Internal Registers	1
F101 0000	F1FF FFFF	16MB - 64KB	Unassigned	
F200 0000	F3FF FFFF	32MB	PCI Bus 0 Memory Space 1	
F400 0000	F5FF FFFF	32MB	PCI Bus 0 Memory Space 2	
F600 0000	F7FF FFFF	32MB	PCI Bus 0 Memory Space 3	
F800 0000	FEFF FFFF	112MB	Unassigned	
FF00 0000	FF7F FFFF	8MB	Device Port CS3	
FF80 0000	FFFF FFFF	8MB	Boot Flash Bank	2

- Notes**
1. Set by configuration resistors.
 2. Selects Flash 0 or Flash 1 depending on the state of the Flash boot bank select jumper.

MOTLoad's Processor Memory Map

MOTLoad's processor memory map is given in the following table.

Table 1-3. MOTLoad's Processor Memory Map

Processor Address		Size	Definition	Notes
Start	End			
0000 0000	7FFF FFFF	2GB	On-Board SDRAM	1
8000 0000	DFFF FFFF	1.5GB	PCI 0 Domain Memory Space	
E000 0000	FFFF FFFF	256MB	PCI 1 Domain Memory Space	
F000 0000	F07F FFFF	8MB	PCI 0 Domain I/O Space	2
F080 0000	F0FF FFFF	8MB	PCI 1 Domain I/O Space	2

Table 1-3. MOTLoad's Processor Memory Map (continued)

Processor Address		Size	Definition	Notes
Start	End			
F100 0000	F10F FFFF	1MB	GT-64260B Internal Registers	
F110 0000	F11F FFFF	1MB	GT-64260B Device Bus Registers	3
F120 0000	F1FF FFFF	14MB	Reserved	
F200 0000	FE00 0000	32MB	Flash Bank 0	4
FF80 0000	FFFF FFFF	8MB	Flash Bank 1	4

- Notes**
1. Maximum size is 2GB. Actual size depends on the amount of memory installed.
 2. Zero-based I/O space.
 3. Device chip select 1.
 4. Flash 0/Flash 1 can be mapped to device chip select 0 or BOOT chip select depending on the state of the Flash boot bank select header.

Default PCI Memory Map

Table 1-4 is the default PCI memory map for each PCI bus following reset.

Table 1-4. Default PCI Memory Map

PCI Address		Size	Definition
Start	End		
0000 0000	007F FFFF	8MB	SDRAM Bank 0
0080 0000	00FF FFFF	8MB	SDRAM Bank 1
0100 0000	017F FFFF	8MB	SDRAM Bank 2
0180 0000	01FF FFFF	8MB	SDRAM Bank 3
0200 0000	0FFF FFFF	224MB	Unassigned

Table 1-4. Default PCI Memory Map (continued)

PCI Address		Size	Definition
Start	End		
1000 0000	11FF FFFF	32MB	PCI Bus 1 P2P I/O Space
1200 0000	13FF FFFF	32MB	PCI Bus 1 P2P Memory Space 0
1400 0000	1400 FFFF	64KB	Internal Registers
1401 0000	1BFF FFFF	128MB - 64KB	Unassigned
1C00 0000	1C7F FFFF	8MB	Device Port CS0
1C80 0000	1CFF FFFF	8MB	Device Port CS1
1D00 0000	1DFF FFFF	16MB	Device Port CS2
1E00 0000	1FFF FFFF	32MB	Unassigned
2000 0000	21FF FFFF	32MB	PCI Bus 0 P2P I/O Space
2200 0000	23FF FFFF	32MB	PCI Bus 0 P2P Memory Space 0
2400 0000	25FF FFFF	32MB	PCI Bus 0 P2P Memory Space 1
2600 0000	F1FF FFFF	3264MB	Unassigned
F200 0000	F3FF FFFF	32MB	PCI Bus 1 P2P Memory Space 1
F400 0000	FEFF FFFF	176MB	Unassigned
FF00 0000	FF7F FFFF	8MB	Device Port CS3
FF80 0000	FFFF FFFF	8MB	Boot Flash Bank

MOTLoad's PCI Memory Maps

MOTLoad's PCI memory map for each PCI domain is shown in the following tables.

Table 1-5. MOTLoad's PCI 0 Domain Memory Map

PCI 0 Memory Address		Size	Definition
Start	End		
0000 0000	7FFF FFFF	2GB	On-Board SDRAM
8000 0000	DFFF FFFF	768MB	Local PCI 0 Domain Memory Space
F000 0000	FFFF FFFF	256MB	Reserved

Table 1-6. MOTLoad's PCI 1 Domain Memory Map

PCI 1 Memory Address		Size	Definition
Start	End		
0000 0000	7FFF FFFF	2GB	On-Board SDRAM
E000 0000	FFFF FFFF	1GB	Local PCI 1 Domain Memory Space
F000 0000	FFFF FFFF	256MB	Reserved

PCI I/O Space Maps

The PCI I/O space map for each PCI domain is shown in the following tables.

Table 1-7. PCI 0 Domain I/O Map

PCI 0 I/O Address		Size	Definition
Start	End		
0000 0000	007F FFFF	8MB	Local PCI Domain I/O Space

Table 1-8. PCI 1 Domain I/O Map

PCI 1 I/O Address		Size	Definition
Start	End		
0000 0000	007F FFFF	8MB	Local PCI Domain I/O Space

System I/O Memory Map

System resources for the MVME5500 board including system control and status registers, NVRAM/RTC, and the 16550 UARTs are mapped into a 1MB address range assigned to device bank 1. The region defined by device bank 1 resides within the GT-64260B device bus register's space listed in [Table 1-3 on page 1-6](#). The memory map is defined in the following table:

Table 1-9. Device Bank 1 I/O Memory Map

Device Bank1 Address Offset	Definition
0 0000	System Status Register 1
0 0001	System Status Register 2
0 0002	System Status Register 3
0 0003	Reserved
0 0004	Presence Detect Register
0 0005	Software Readable Header/Switch
0 0006	Timebase Enable Register
0 0007	Geographical Address Register (VME board)
0 0008 - 0 FFFF	Reserved for future on-board registers
1 0000 - 1 7FFF	M48T37V NVRAM/RTC
2 0000 - 2 0FFF	COM1 16550 UART
2 1000 - 2 1FFF	COM2 16550 UART
2 4000 - F FFFF	Reserved (undefined)

System Status Register 1

The MVME5500 board system status register 1 is used to provide board status information and software control of Abort.

Table 1-10. System Status Register 1

REG	System Status Register 1 - Offset 0x0 0000							
BIT	7	6	5	4	3	2	1	0
FIELD	REF_CLK	BANK_SEL	SAFE_START	ABORT_	FLASH_BSY_	FUSE_STAT	RSVD	RSVD
OPER	R	R	R	R/W	R	R	R	R
RESET	X	X	X	1	X	X	0	0

REF_CLK

Reference clock. This bit reflects the current state of the 28.8 KHz reference clock derived from the 1.8432 MHz UART oscillator divided by 64. This clock may be used as a fixed timing reference.

BANK_SEL

Boot Flash bank select. This bit reflects the current state of the boot Flash bank select jumper. A cleared condition indicates that Flash 0 is the boot bank. A set condition indicates that Flash 1 is the boot bank.

SAFE_START

ENV safe start. This bit reflects the current state of the ENV safe start select jumper. A cleared condition indicates that the ENV settings programmed in NVRAM, VPD, and SPD should be used by the firmware. A set condition indicates that firmware should use the safe ENV settings.

ABORT_

This bit reflects the current state of the on-board abort signal. Writing a 0 at this bit position asserts the abort interrupt output signal, while writing a 1 at this bit position clears the abort interrupt output signal. Reading a 1 at this bit position indicates that the abort switch is deasserted, while reading a 0 at this bit position indicates that the abort switch is asserted.

FLASH_BSY_

Flash busy. This bit provides the current state of the Flash 0 StrataFlash device status pins. These two open drain output pins are wire ORed. Refer to the appropriate *Intel StrataFlash data sheet* for a description on the function of the status pin.

FUSE_STAT

Fuse status. This bit indicates the status of the soldered, on-board fuses (R199 and R188). A cleared condition indicates that one of the fuses is open. A set condition indicates that all fuses are functional.

System Status Register 2

The MVME5500 board system status register 2 provides board control and status bits.

Table 1-11. System Status Register 2

REG	System Status Register 2 - Offset 0x0 0001							
BIT	7	6	5	4	3	2	1	0
FIELD	BD_FAIL	EEPROM_WP	FLASH_WP	TSTAT_MASK	RSVD	PCI 0.1_M66EN	PCI 1.0_M66EN	PCI 0.0_M66EN
OPER	R/W	R/W	R/W	R/W	R	R	R	R
RESET	1	1	1	1	0	0	X	X

BD_FAIL

Board fail. This bit is used to control the board fail LED. A set condition illuminates the front-panel LED and a cleared condition extinguishes the front-panel LED.

EEPROM_WP

EEPROM write protect. This bit is to provide protection against inadvertent writes to the on-board EEPROM devices. Clearing the bit enables writes to the EEPROM devices. Setting this bit write protects the devices. The devices are write protected following a reset.

FLASH_WP

Flash write protect. This bit is used to provide protection against inadvertent writes to both Flash 0 and Flash 1 memory devices. Clearing this bit enables writes to the Flash devices. Setting this bit write protects the devices. This bit is set during reset and must be cleared by the system software to enable writing of the Flash devices.

TSTAT_MASK

Thermostat mask. This bit is used to mask the DS1621 temperature sensor thermostat output. If this bit is cleared, the thermostat output is enabled to generate an interrupt on GPP 3. If the bit is set, the thermostat output is disabled from generating an interrupt.

PCI0.1_M66EN

PCI Bus 0.1 M66EN. This bit reflects the state of the PCI Bus 0.1 M66EN pin. A cleared condition indicates that PCI Bus 0.0 is operating at 33 MHz. A set condition indicates that the bus is operating at 66 MHz. This bit is always cleared on the MVME5500.

PCI1.0_M66EN

PCI Bus 1.0 M66EN. This bit reflects the state of the PCI Bus 1.0 M66EN pin. A cleared condition indicates that PCI Bus 1.0 is operating at 33 MHz. A set condition indicates that the bus is operating at 66 MHz.

PCI0.0_M66EN

PCI Bus 0.0 M66EN. This bit reflects the state of the PCI Bus 0.0 M66EN pin. A cleared condition indicates that PCI Bus 0 is operating at 33 MHz. A set condition indicates that the bus is operating at 66 MHz.

System Status Register 3

The MVME5500 board system status register 3 provides the board software-controlled reset functions.

Table 1-12. System Status Register 3

REG	System Status Register 3 - Offset 0x0 0002							
BIT	7	6	5	4	3	2	1	0
FIELD	BRD_RST	RSVD	RSVD	RSVD	ABT_INT_MASK	RSVD	RSVD	RSVD
OPER	W	R	R	R	R/W	R	R	R
RESET	0	0	0	0	1	0	0	0

BRD_RST

Board reset. Setting this bit forces a hard reset of the MVME5500 board. This bit clears automatically when the board reset is complete.

ABT_INT_MASK

Abort interrupt mask. This bit is used to mask the abort interrupt. If this bit is set, the abort interrupt is masked so the abort interrupt is not generated. If the bit is cleared, the abort interrupt may be generated.

Presence Detect Register

The MVME5500 board contains a presence detect register that may be read by the system software to determine the presence of optional devices.

Table 1-13. Presence Detect Register

REG	Presence Detect Register - Offset 0x0 0004h							
BIT	7	6	5	4	3	2	1	0
FIELD	RSVD	RSVD	RSVD	RSVD	RSVD	PMC_SPANP_	PMC2P_	PMC1P_
OPER	R	R	R	R	R	R	R	R
RESET	1	1	1	1	1	X	X	X

PMC_SPANP_

PMC expansion module present. If set, there is no PMC expansion module installed. If cleared, the PMC expansion module is installed.

PMC2P_

PMC module 2 present. If set, there is no PMC module installed in position 2. If cleared, the PMC module is installed.

PMC1P_

PMC module 1 present. If set, there is no PMC module installed in position 1. If cleared, the PMC module is installed.

Configuration Header/Switch Register (S1)

The MVME5500 board has an 8-bit header or switch that may be read by the software.

Table 1-14. Configuration Header/Switch Register

REG	Configuration Header/Switch Register - Offset 0x0 0005h							
BIT	7	6	5	4	3	2	1	0
FIELD	CFG_7	CFG_6	CFG_5	CFG_4	CFG_3	CFG_2	CFG_1	CFG_0
OPER	R	R	R	R	R	R	R	R
RESET	X	X	X	X	X	X	X	X

CFG[7-0]

Configuration bits 7-0. These bits reflect the position of the switch installed in the software readable header location. A cleared condition indicates that the switch is ON for the header position associated with that bit and a set condition indicates that the switch is OFF.

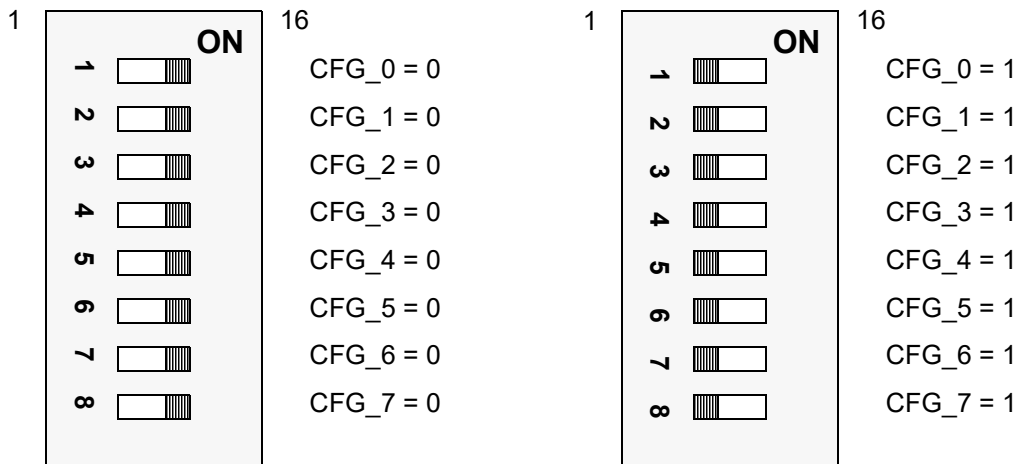

Time Base Enable Register

The time base enable (TBEN) register provides the means to control the processor's TBEN input.

Table 1-15. TBEN Register

REG	TBEN Register- Offset 0x0 0006							
BIT	7	6	5	4	3	2	1	0
FIELD	RSVD	RSVD	RSVD	RSVD	RSVD	RSVD	RSVD	TBEN0
OPER	R	R	R	R	R	R	R	R/W
RESET	0	0	0	0	0	0	0	1

TBEN0

Processor time base enable. When this bit is cleared, the TBEN pin of the processor is driven low. When this bit is set, the TBEN pin is driven high.

Geographical Address Register (S2)

This register reflects the inverted states of the geographical address pins at the 5-row, 160-pin P1 connector. Applications not using the 5-row backplane can use a planar switch (same type as the [Configuration Header/Switch Register \(S1\) on page 1-17](#)) to assign a geographical address according to the following diagram.

Note The switch positions must all be turned off when the MVME5500 is used in a 5-row backplane.

Table 1-16. Geographical Address Register

REG	Geographical Address Register - 0xFF100007							
BIT	7	6	5	4	3	2	1	0
FIELD	VMEGA0 ₁	VMEGA1 ₁	VMEGA2 ₁	VMEGA3 ₁	VMEGA4 ₁	RSVD	RSVD	VMEGAP ₁
OPER	R	R	R	R	R	R	R	R
RESET	X	X	X	X	X	X	X	X

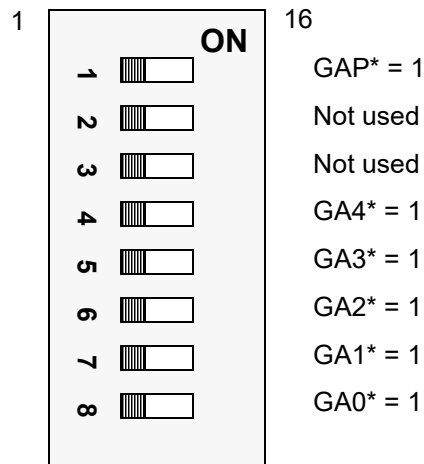
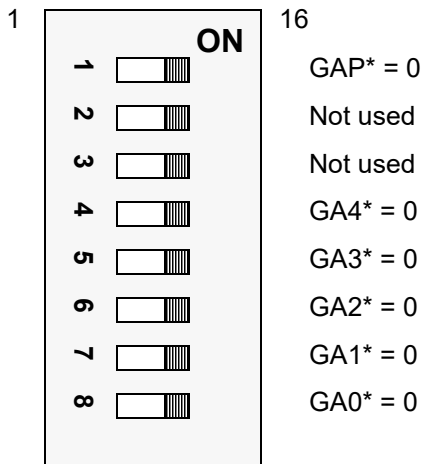

COM1 & COM2 Universal Asynchronous Receiver/Transmitter (UART)

COM1 and COM2 are PC16550 Universal Asynchronous Receiver/Transmitter (UART) to provide an asynchronous serial interface for test/debug purposes. To facilitate proper baud rate generation, the frequency of the input clock for the PC16550 UART is fixed at 1.8432 MHz. For additional programming details, refer to the *PC16550 Data Sheet*.

Real-Time Clock and NVRAM

The SGS-Thomson M48T37 is used by the MVME5500 board to provide 32KB of non-volatile static RAM, real-time clock, and watchdog timer functions. The device is accessed as linear memory. Refer to the *MK48T37 Data Sheet* for programming information.

ISA Local Resource Bus

The ISA local resources exist *only* if an IPMC712/761 module is mounted on the MVME5500. Refer to the *IPMC712/761 I/O Module Installation and Use*, listed in [Appendix B, Related Documentation](#).

Introduction

This chapter includes additional programming information for the MVME5500 single-board computer. Items discussed include:

- ❑ [PCI Configuration Space and IDSEL Mapping on page 2-1](#)
- ❑ [Interrupt Controller on page 2-3](#)
- ❑ [Two-Wire Serial Interface on page 2-5](#)
- ❑ [GT-64260B Initialization on page 2-7](#)
- ❑ [GT-64260B GPP Configuration on page 2-7](#)
- ❑ [GT-64260B Reset Configuration on page 2-9](#)
- ❑ [GT-64260B Device Controller Bank Assignments on page 2-11](#)
- ❑ [System Clock Generators on page 2-13](#)
- ❑ [VPD and User Configuration EEPROMs on page 2-14](#)
- ❑ [Temperature Sensor on page 2-14](#)
- ❑ [Flash Memory on page 2-14](#)
- ❑ [PCI Arbitration Assignments on page 2-14](#)
- ❑ [Other Software Considerations on page 2-15](#)

PCI Configuration Space and IDSEL Mapping

Each PCI device has an associated address line connected via a resistor to its IDSEL pin for configuration space accesses. [Table 2-1](#) shows the IDSEL assignments for the PCI devices on each of the PCI buses on the MVME5500 board along with the corresponding interrupt assignment to the general-purpose port (GPP) pins. Refer to the *GT-64260B System Controller for PowerPC Processors Data Sheet* and the *PCI 6154 (HB2) PCI-to-PCI Bridge Data Book*, both listed in [Appendix B, Related](#)

[Documentation](#), for details on generating configuration cycles on each of the PCI buses.

Table 2-1. IDSEL Mapping for PCI Devices

PCI Bus	Device Number Field	PCI AD Line	Physical PCI Device	Device INT# to GPP Interrupt Input			
				INTA#	INTB#	INTC#	INTD#
0.0	0b0_0001	AD11	IPMC	11			
	0b0_0110	AD16	PMC 1 (J11,12,13,14)	8	9	10	11
	0b0_0111	AD17	PMC 1 IDSEL B				
	0b0_1010	AD20	HiNT PCI 6154 Bridge				
	0b1_0101	AD31	GT-64260B PCI Bridge				
0.1	0b0_0000	AD16	CA91C142D VME VLINT0	12			
			CA91C142D VME VLINT1	13			
			CA91C142D VME VLINT2	14			
			CA91C142D VME VLINT3	15			
	0b0_0100	AD20	PMC Expansion	12	13	14	15
				<p>Note Device-specific interrupt routing is established on the PMCspan board. Refer to the <i>PMCspan PMC Adapter Carrier Board Installation and Use</i> manual, listed in Appendix B, Related Documentation.</p>			

Table 2-1. IDSEL Mapping for PCI Devices (continued)

PCI Bus	Device Number Field	PCI AD Line	Physical PCI Device	Device INT# to GPP Interrupt Input			
				INTA#	INTB#	INTC#	INTD#
1.0	0b0_0110	AD16	PMC 2 (J21,22,23,24)	16	17	18	19
	0b0_0111	AD17	PMC 2 IDSEL B				
	0b0_1010	AD20	82C544 Ethernet 1	20			
	0b1_0101	AD31	GT-64260B PCI Bridge				

Interrupt Controller

The MVME5500 uses the GT-64260B interrupt controller to handle interrupts internal to the GT-64260B, as well as the external interrupt sources. The GT-64260B has a limited number of directly triggerable interrupt inputs. Each of the GPP pins can be configured for an interrupt input, but the inputs are combined internally in groups of eight inputs (one for each byte lane) for one interrupt source. Therefore, interrupt inputs in each byte lane are essentially shared. Currently defined external interrupting devices and GPP interrupt assignments are shown in [Table 2-2](#).

The GT-64260B has one dedicated processor interrupt output, CPUINT₀, which is connected to the primary processor CPU0 INT_L input. Refer to

the *GT-64260B System Controller for PowerPC Processors Data Sheet*, listed in [Appendix B, Related Documentation](#), for details.

Table 2-2. GT-64260B External GPP Interrupt Assignments

GPP Group	GPP #	Edge/Level	Polarity	Interrupt Source
0	0	Level	High	COM1 COM2
	1	Level	Low	Not Used. Pulled High.
	2	Level	Low	Abort Switch
	3	Level	Low	RTC Thermostat Output
	4	Level	Low	Not Used. Pulled high, tied to GPP27.
	5	Level	Low	Not Used. Pulled high, tied to GPP28.
	6	Level	Low	GT-64260B WDMNI Interrupt. Tied to GPP24.
	7	Level	Low	LXT971A Interrupt (10/100Mbit PHY)
1	8	Level	Low	PMC 1 Interrupt INT A
	9	Level	Low	PMC 1 Interrupt INT B
	10	Level	Low	PMC 1 Interrupt INT C
	11	Level	Low	PMC 1 Interrupt INT D IPMC INT
	12	Level	Low	VME Interrupt VLINT0
	13	Level	Low	VME Interrupt VLINT1
	14	Level	Low	VME Interrupt VLINT2
	15	Level	Low	VME Interrupt VLINT3

Table 2-2. GT-64260B External GPP Interrupt Assignments (continued)

GPP Group	GPP #	Edge/Level	Polarity	Interrupt Source
2	16	Level	Low	PMC 2 Interrupt INT A
	17	Level	Low	PMC 2 Interrupt INT B
	18	Level	Low	PMC 2 Interrupt INT C
	19	Level	Low	PMC 2 Interrupt INT D
	20	Level	Low	82544 Interrupt
	21	Level	Low	Not Used. Pulled High.
	22	Level	Low	Not Used. Pulled High.
	23	Level	Low	Not Used. Pulled High.
3	24			Watchdog Timer NMI Output WDNMI# to GPP6
	25			Watchdog Timer Expired Output WDE#
	26			GT-64260B SROM Initialization Active InitAct
	27	Level	Low	Not Used. Pulled high, tied to GPP4.
	28			Not Used. Pulled high, tied to GPP5.
	29			Optional External PPC Bus Arbiter BG1 Enable
	30			Unused. Pulled High.
	31			Unused. Pulled High.

Two-Wire Serial Interface

A two-wire serial interface for the MVME5500 board is provided by an I2C compatible serial controller integrated into the GT-64260B system controller. The I2C serial controller provides two basic functions. The first function is to provide GT-64260B register initialization following a reset. The GT-64260B can be configured (by jumper setting) to automatically read data out of a serial EEPROM following a reset and initialize any number of internal registers. In the second function, the controller is used by the system software to read the contents of the VPD EEPROM

contained on the MVME5500 board, along with the SPD EEPROMs, to further initialize the memory controller and other interfaces. For additional details regarding the GT-64260B two-wire serial controller operation, refer to the *GT-64260B System Controller for PowerPC Processors Data Sheet*, listed in [Appendix B, Related Documentation](#).

[Table 2-3](#) shows the I2C devices used for the MVME5500 and the assigned device IDs.

Table 2-3. I2C Bus Device Addressing

Device Function	Size	Device Address (A2A1A0)	I2C BUS Address	Notes
Memory SPD (On-board. Banks A and B.)	256 x 8	000b	\$A0	1, 2
Memory SPD (On mezzanine. Banks C and D.)	256 x 8	001b	\$A2	1
IPMC VPD	256 x 8	010b	\$A4	
GT-64260B Fixed Initialization	256 x 8	011b	\$A6	2
Configuration VPD	8K x 8	100b	\$A8	2, 3
User VPD	8K x 8	101b	\$AA	2, 3
Not Used	NA	110b	\$AC	
Not Used	NA	111b	\$AE	
DS1621 Temperature Sensor	NA	000b	\$90	

- Notes**
1. Each SPD defines the physical attributes of each bank or group of banks, that is, if both banks of a group are populated, they will be the same speed and memory size.
 2. This device can be write-protected by either setting the EEPROM_WP bit of SSR2 or by placing a jumper on the EEPROM write protect header. The hardware jumper mechanism always takes precedence over the software setting. For 8KB sized parts, only the upper 2KB are write-protectable.
 3. This is a 2-byte address serial EEPROM (AT24C64).

GT-64260B Initialization

Serial EEPROM devices are provided to support optional initialization of the GT-64260B (enabled by an on-board jumper). Using the SROM initialization method, any of the GT-64260B internal registers or other system components (that is, devices on the PCI bus) can be initialized. Initialization takes place by sequentially reading 8-byte address/data pairs from the SROM and writing the 32-bit data to the decoded 32-bit address until the data pattern matching the last serial data item register is read for the SROM (default value = 0xffffffff). The on-board reset logic keeps the processor reset asserted until this initialization process is completed.

GT-64260B GPP Configuration

The GT-64260B contains a 32-bit GPP. The GPP pins can be configured as general-purpose I/O pins, as external interrupt inputs, or as specific control/status pins for one of the GT-64260B internal devices. After reset, all GPP pins default to general-purpose inputs. Software must then configure each of the pins for the desired function. The following table defines the function assigned to each GPP pin on the MVME5500 board.

Table 2-4. GT-64260B GPP Pin Function Assignments

GPP Number	Input/Output	Function
0	I	COM1/COM2 interrupts (ORed)
1	I	Not Used. Pulled High.
2	I	Abort Interrupt
3	I	RTC and Thermostat Interrupts (ORed)
4	O	Not Used. Pulled high, tied to GPP27.
5	I	Not Used. Pulled high, tied to GPP28.
6	I	GT-64260B WDMNI Interrupt. Tied to GPP24.
7	I	LXT971A Interrupt (10/100Mbit PHY)
8	I	PMC 1 Interrupt INT A

Table 2-4. GT-64260B GPP Pin Function Assignments (continued)

GPP Number	Input/Output	Function
9	I	PMC 1 Interrupt INT B
10	I	PMC 1 Interrupt INT C
11	I	PMC 1 Interrupt INT D/IPMC INT
12	I	VME Interrupt 0
13	I	VME Interrupt 1
14	I	VME Interrupt 2
15	I	VME Interrupt 3
16	I	PMC 2 Interrupt INT A
17	I	PMC 2 Interrupt INT B
18	I	PMC 2 Interrupt INT C
19	I	PMC 2 Interrupt INT D
20	I	82544 Interrupt
21	I	Not Used. Pulled High.
22	I	Not Used. Pulled High.
23	I	Not Used. Pulled High.
24	O	Watchdog Timer NMI Output WDNMI# to GPP6
25	O	Watchdog Timer Expired Output WDE#
26	O	GT-64260B SROM Initialization Active InitAct
27	I	Not Used. Pulled high, tied to GPP4.
28	O	Not Used. Pulled high, tied to GPP5.
29	O	Optional external PPC Bus Arbiter BG1 Enable.
30	I	Not Used. Pulled High.
31	I	Not Used. Pulled High.

GT-64260B Reset Configuration

The GT-64260B supports two methods of device initialization following reset:

- Pins sampled on the deassertion of reset
- Partial pin sample on deassertion of reset plus serial ROM initialization via the I2C bus

The MVME5500 board supports both options listed above. An on-board jumper setting is used to select the option. If the pin-sample-only method is selected, then states of the various pins on the device AD bus are sampled when reset is deasserted to determine the desired operating modes. [Table 2-5 on page 2-10](#) describes the configuration options. Combinations of pullups, pulldowns, and jumpers are used to set the options. Some options are fixed and some are selectable at build time by installing the proper pullup/pulldown resistor. Finally, some options may be selected using on-board jumpers.

Using the SROM initialization method, any of the GT-64260B internal registers or other system components (that is, devices on the PCI bus) can be initialized. Initialization takes place by sequentially reading 8-byte address/data pairs from the SROM and writing the 32-bit data to the decoded 32-bit address until the last serial data item of 0xffffffff is read. If the SROM initialization option is selected, the following pins are still sampled to determine certain operating parameters:

- AD(1) – SROM byte offset width
- AD(3:2) – SROM address
- AD(4) – CPU endianness

- AD(30:28) – PLL settings
- AD(31) – CPU interface voltage

Table 2-5. GT-64260B Power-Up Configuration Settings

Device AD Bus Signal	Select Option	Default Power-Up Setting	Description	State of Bit vs. Function	
AD[0]	Jumper	x	SROM Initialization	0	No SROM Initialization
				1	SROM Initialization Enabled
AD[1]	Resistor	0	SROM Byte Offset Width	0	Up to 8 Bits
AD[3:2]	Resistors	11	SROM Device Address	11	1010011 (\$A6)
AD[4]	Fixed	0	CPU Data Endianess	0	Must be Pulled Down
AD[5]	Fixed	1	CPU Interface Clock	1	CPU Interface Synchronous with TClk
AD[6]	Jumper	x	CPU Bus Configuration	0	60x Bus Mode
				1	MPX Bus Mode
AD[8]	Resistor	1	Internal 60x Bus Arbiter	1	Internal Arbiter Enabled
AD[9]	Fixed	0	Multiple GT-64260B Support	0	Not Supported
AD[11:10]	Fixed	11	Multiple GT-64260B Address ID	11	GT Responds to CPU Address A[5:6] = 11
AD[12]	Fixed	0	SDRAM UMA	0	Not Supported
AD[13]	Fixed	0	UMA Device Type	0	UMA Master
AD[15:14]	Fixed	10	BootCS* Device Width	10	32 Bits
AD[16]	Resistor	1	PCI Retry	1	Enable

Table 2-5. GT-64260B Power-Up Configuration Settings (continued)

Device AD Bus Signal	Select Option	Default Power-Up Setting	Description	State of Bit vs. Function	
AD[17]	Fixed	0	PCI_0 Expansion ROM	0	Not Supported
AD[18]	Fixed	0	PCI_1 Expansion ROM	0	Not Supported
AD[22:19]	Fixed	0000	Reserved	0000	Must be Pulled Down
AD[23]	Fixed	1	SDClkIn/ SDClkOut Select	1	SDClkIn
AD[24]	Resistor	1	Internal Space Default Address	1	0xf100.0000
AD[27:25]	Fixed	000	Reserved	000	Must be Pulled Down
AD[28]	Resistor	0	PLL Tune	0	Tuning Option 0
AD[29]	Resistor	0	PLL Divider	0	Divider Option 0
AD[30]	Resistor	0	PLL Bypass	0	PLL Enabled
AD[31]	Fixed	0	CPU Interface Voltage	0	2.5V

GT-64260B Device Controller Bank Assignments

The MVME5500 board uses three of the GT-64260B device controller banks for interfacing to various devices. The following tables define the device bank assignments and the programmable device bank timing parameters required for each of the banks used. Note that all device bank

timing parameters, except *BAdrSkew*, have an extension bit that forms the most significant bit of the timing parameter.

Table 2-6. Device Bank Assignments

Device Bank	Data Width	Function	Note
0	32 bit	Flash 0 Soldered Flash or Flash 1 Soldered Flash	1
1	8 bit	I/O Devices	
2	NA	Not used	
3	NA	Not used	
Boot	32 bit	Flash 1 Soldered Flash or Flash 0 Soldered Flash	1

Note 1. Determined by Flash boot bank select jumper.

Table 2-7. Device Bank Timing Parameters

Device Bank	GT-64260B Tclk Clock Freq.	Device Bank Timing Parameter Min. Value						
		Acc2FirstExt - Acc2First	Acc2NextExt - Acc2Next	TurnOffExt - TurnOff	ALE2WrExt - ALE2Wr	WrLowExt - WrLow	WrHighExt - WrHigh	BAdrSkew
Flash 0 (150 ns)	100 MHz	1 - 1	0 - 3	0 - 6	0 - 3	0 - 7	0 - 4	0
	133 MHz	1 - 6	0 - 4	0 - 8	0 - 3	1 - 2	0 - 5	0
Flash 0 (120 ns)	100 MHz	0 - e	0 - 3	0 - 6	0 - 3	0 - 7	0 - 4	0
	133 MHz	1 - 2	0 - 4	0 - 8	0 - 3	1 - 2	0 - 5	0

Table 2-7. Device Bank Timing Parameters (continued)

Device Bank	GT-64260B Telk Clock Freq.	Device Bank Timing Parameter Min. Value						
		Acc2FirstExt - Acc2First	Acc2NextExt - Acc2Next	TurnOff Ext - TurnOff	ALE2WrExt - ALE2Wr	WrLowExt - WrLow	WrHighExt - WrHigh	BAdrSkew
Flash 0 (100 ns)	100 MHz	0 - c	0 - 3	0 - 6	0 - 3	0 - 7	0 - 4	0
	133 MHz	1 - 0	0 - 4	0 - 8	0 - 3	1 - 2	0 - 5	0
Device Bank 1 I/O	100 MHz	0 - c	0 - a	0 - 5	0 - 3	1 - 0	0 - 4	0
	133 MHz	1 - 0	0 - e	0 - 7	0 - 3	1 - 3	0 - 6	0
Flash 1 (90 ns)	100 MHz	0 - b	0 - 9	0 - 3	0 - 3	0 - 4	0 - 3	0
	133 MHz	0 - e	0 - c	0 - 4	0 - 3	0 - 5	0 - 4	0

Note Flash 0 contains 100 ns, 120 ns, or 150 ns StrataFlash devices. Device speed can be determined from VPD.

System Clock Generators

The system clock generator functions generate and distribute all of the clocks required for system operation. The clocks for the processor, memory, and PCI devices consist of a clock tree derived from a 66 MHz oscillator and a series of PLL clock generators. The clock tree is designed in such a manner as to maintain the strict edge-to-edge jitter and low clock-to-clock skew required by these devices. Additional clocks required by individual devices are generated near the devices using individual oscillators.

VPD and User Configuration EEPROMs

The MVME5500 board contains an Atmel AT24C64 vital product data (VPD) EEPROM containing configuration information specific to the board. Typical information that may be present in the VPD is: manufacturer, board revision, build version, date of assembly, memory present, options present, L3 cache information, etc. A second AT24C64 device is available for user data storage.

Temperature Sensor

The MVME5500 board contains a Maxim DS1621 digital temperature sensor with an I2C serial bus interface. This device may be used to provide a measure of the ambient temperature of the board.

Flash Memory

The MVME5500 contains two banks of Flash memory accessed via the device controller contained within the GT-64260B. Flash 1 consists of two soldered 32Mb devices (E28F320J3A) to give a minimum of 8MB Flash memory. Flash 0 consists of two Intel StrataFlash 3.3 volt devices, configured to operate in 16-bit mode, to form a 32-bit Flash port. This bank contains 64Mb devices (E28F128J3A) for 32MB of Flash.

There is a Flash boot bank select jumper on board, which selects either Flash 0 or Flash 1 as the boot bank. No jumper or a jumper installed between pins 1 and 2 selects Flash 0 as the boot bank. A jumper installed between pins 2 and 3 selects Flash 1 as the boot bank.

PCI Arbitration Assignments

PCI arbitration for PCI Bus 0.0 and PCI Bus 1.0 is handled using logic implemented in PLDs. These arbiters use a rotating priority scheme for fairness and bus parking will always be on the GT-64260B. There are no software programmable modes to these arbiters.

PCI arbitration for PCI Bus 0.1 is provided by the HiNT PCI 6154 secondary side arbiter.

Table 2-8. PCI Arbiter Assignments

PCI Bus Number	REQ/GNT Pair	PCI Device
0.0	0	GT-64260B Host
	1	PMC Req 1
	2	PMC Req 2
	3	PCI-to-PCI Bridge (HiNT PCI 6154)
	4	Not Used
0.1	0	PCI/PMC Expansion
	1	VME Controller
1.0	0	GT-64260B Host
	1	PMC Req 1
	2	PMC Req 2
	3	82544
	4	Not Used

Other Software Considerations

The following subsections discuss software aspects of the CPU bus, processor, and cache that can have an influence on the MVME5500.

CPU Bus Mode

The CPU bus operating mode (60x or MPX) is determined by reading the BMODE bits (bits 16-17) in the processor's Memory Subsystem Control Register (MSSCR0). The power-up state of the BMODE(0:1) pins is captured in these register bits. Refer to the *MPC7450 RISC*

Microprocessor User's Manual, listed in [Appendix B, Related Documentation](#), for details.

Processor Type Identification

Software can determine the processor version through the version register. The most significant 16 bits (0:15) of the MPC7455 processor version register reads as 0x8001.

Processor PLL Configuration

The processor internal clock frequency (core frequency) is a multiple of the system bus frequency. The processor has five configuration pins, PLL_EXT and PLL_CFG[0:3], for hardware strapping of the processor core frequency (between 2x and 16x of the system bus frequency).

L1, L2, L3 Cache

The processors support on-chip L1 and L2 caches and external L3 cache. L3 cache supports 1 or 2MB in a variety of SRAM device types. Each processor L3 interface on the MVME5500 consists of two 8Mb devices (K7D803671B-HC30) providing a total of 2MB of L3 cache. Data parity checking should be enabled. The following processor L3CR register settings assume a processor speed of 933 MHz and L3 clock speed of 233 MHz.

Table 2-9. Processor L3CR Register Assignments

Apollo L3CR Register	Description	Value
L3SIZ	L3 Size, 2 MB	1
L3RT	L3 SRAM Type, DDR SRAM	00

Table 2-9. Processor L3CR Register Assignments

Apollo L3CR Register	Description	Value
L3PE	L3 Data Parity Checking Enable, ON	1
L3CLK	L3 Clock Speed; 233 MHz, Divide by 4	110
L3CKSP	L3 Clock Sample Point, 2 Clocks	TBD
L3PSP	L3 P-Clock Sample Point, 3 Clocks	TBD

This appendix gives an overview of the vital product data (VPD) required for the MVME5500.

Flash Memory Configuration Data

The Flash memory configuration data packet consists of byte fields that indicate the size/organization/type of the Flash memory array. [Table A-1](#) and [Table A-2](#) further describe the Flash memory configuration VPD data packet.

Table A-1. Flash 0 Memory Configuration Data

Byte Offset	Field Size (Bytes)	Field Mnemonic	Field Description
00	2	FMC_MID	Manufacturer's Identifier
02	2	FMC_DID	Manufacturer's Device Identifier
04	1	FMC_DDW	Device Data Width (16 bits on MVME5500)
05	1	FMC_NOD	Number of Devices Present (two on MVME5500)
06	1	FMC_NOC	Number of Columns (Interleaves) (two on MVME5500)
07	1	FMC_CW	Column Width in Bits (16 on MVME5500) This will always be a multiple of the device's data width.

Table A-1. Flash 0 Memory Configuration Data (continued)

Byte Offset	Field Size (Bytes)	Field Mnemonic	Field Description
08	1	FMC_WEDW	Write/Erase Data Width (16 on MVME5500) The Flash memory devices must be programmed in parallel when the write/erase data width exceeds the device's data width.
09	1	FMC_BANK	Bank Number of Flash Memory Array: 0 for this bank
0A	1	FMC_SPEED	ROM Access Speed in Nanoseconds
0B	1	FMC_SIZE	Total Bank Size (Should agree with the physical organization above): 07 = 32M

Table A-2. Flash 1 Memory Configuration Data

Byte Offset	Field Size (Bytes)	Field Mnemonic	Field Description
00	2	FMC_MID	Manufacturer's Identifier (FFFF = Undefined/Not-Applicable)
02	2	FMC_DID	Manufacturer's Device Identifier (FFFF = Undefined/Not-Applicable)
04	1	FMC_DDW	Device Data Width (16 bits on MVME5500)
05	1	FMC_NOD	Number of Devices Present (two on MVME5500)
06	1	FMC_NOC	Number of Columns (Interleaves) (two on MVME5500)
07	1	FMC_CW	Column Width in Bits (16 on MVME5500) This will always be a multiple of the device's data width.

Table A-2. Flash 1 Memory Configuration Data (continued)

Byte Offset	Field Size (Bytes)	Field Mnemonic	Field Description
08	1	FMC_WEDW	Write/Erase Data Width (16 on MVME5500) The two memory devices must be programmed in parallel when the write/erase data width exceeds the device's data width.
09	1	FMC_BANK	Bank Number of Memory Array: 1 for this bank
0A	1	FMC_SPEED	ROM Access Speed in Nanoseconds
0B	1	FMC_SIZE	Total Bank Size (Should agree with the physical organization above): 03 = 2M for this bank

L3 Cache Configuration Data

The L3 cache configuration data packet consists of byte fields that indicate the size/organization/type of the L3 cache memory array. [Table A-3](#) further describes the L3 cache memory configuration VPD data packet.

Table A-3. L3 Cache Configuration Data

Byte Offset	Field Size (Bytes)	Field Description
00	1	Which processor is cache connected to: 01 - 1st Processor
01	1	Cache size: 01 - 2MB
02	1	L3 cache core to cache ratio: (Backside Configurations - setting depends on processor core speed and SRAM capability) 06 - 4:1 (4)
03	1	Cache clock sample point: 02 - 4 clocks

Table A-3. L3 Cache Configuration Data (continued)

Byte Offset	Field Size (Bytes)	Field Description
04	1	Processor clock sample point: 03 - 3 clocks
05	1	Sample point override: 00 - sample point override disabled
06	1	SRAM clock control: 00 - SRAM clock control disabled
07	1	SRAM type: 00 - MSUG2 DDR SRAM
08	1	Data bus error detection type: 01 - parity
09	1	Address bus error detection type: 00 - None

Motorola Computer Group Documents

The Motorola publications listed below are referenced in this manual. You can obtain electronic copies of Motorola Computer Group publications by:

- Contacting your local Motorola sales office
- Visiting Motorola Computer Group's World Wide Web literature site, <http://www.motorola.com/computer/literature>

Table B-1. Motorola Computer Group Documents

Document Title	Motorola Publication Number
MVME5500 Single-Board Computer Installation and Use	V5500A/IH
MVME761 Transition Module Installation and Use	VME761A/IH
MVME712M Transition Module Installation and Use	VME712MA/IH
MOTLoad Firmware Package User's Manual	MOTLODA/UM
IPMC712/761 I/O Module Installation and Use	VIPMCA/IH
PMCSpan PMC Adapter Carrier Board Installation and Use	PMCSpanA/IH

To obtain the most up-to-date product information in PDF or HTML format, visit <http://www.motorola.com/computer/literature>

B

Manufacturers' Documents

For additional information, refer to the following table for manufacturers' data sheets or user's manuals. As an additional help, a source for the listed document is provided. Please note that, while these sources have been verified, the information is subject to change without notice.

Table B-2. Manufacturers' Documents

Document Title and Source	Publication Number
MPC7450 RISC Microprocessor User's Manual Literature Distribution Center for Motorola Telephone: 1-800- 441-2447 FAX: (602) 994-6430 or (303) 675-2150 Web Site: http://e-www.motorola.com/webapp/sps/library/prod_lib.jsp E-mail: ldcformotorola@hibbertco.com	MPC7450UM/D Rev 2
MPC7450 RISC Microprocessor Hardware Specification Literature Distribution Center for Motorola Telephone: 1-800- 441-2447 FAX: (602) 994-6430 or (303) 675-2150 Web Site: http://e-www.motorola.com/webapp/sps/library/prod_lib.jsp E-mail: ldcformotorola@hibbertco.com	MPC7450EC/D Rev 3
GT-64260B System Controller for PowerPC Processors Data Sheet Marvell Technologies, Ltd. Web Site: http://www.marvell.com	MV-S100414-00B
Intel 82544EI Gigabit Ethernet Controller with Integrated PHY Data Sheet Intel Corporation Literature Center 19521 E. 32nd Parkway Aurora CO 80011-8141 Web Site: http://www.intel.com/design/litcentr/index.htm	82544.pdf

Table B-2. Manufacturers' Documents (continued)

Document Title and Source	Publication Number
LXT971A 10/100Mbit PHY Datasheet Intel Corporation Literature Center 19521 E. 32nd Parkway Aurora CO 80011-8141 Web Site: http://www.intel.com/design/litcentr/index.htm	24941402.pdf
3 Volt Synchronous Intel StrataFlash Memory 28F640K3, 28F640K18, 28F128K3, 28F128K18, 28F256K3, 28F256K18 (x16) Intel Corporation Literature Center 19521 E. 32nd Parkway Aurora CO 80011-8141 Web Site: http://www.intel.com/design/litcentr/index.htm	290737-003
3 Volt Intel StrataFlash Memory 28F128J3A, 28F640J3A, 28F320J3A Intel Corporation Literature Center 19521 E. 32nd Parkway Aurora CO 80011-8141 Web Site: http://www.intel.com/design/litcentr/index.htm	290667-005
PCI 6154 (HB2) PCI-to-PCI Bridge Data Book PLX Technology, Inc. 870 Maude Avenue Sunnyvale, California 94085 Web Site: http://www.hintcorp.com/products/hint/default.asp	6154_DataBook_v2.0.pdf

Table B-2. Manufacturers' Documents (continued)

Document Title and Source	Publication Number
TL16C550C Universal Asynchronous Receiver/Transmitter Texas Instruments P. O. Box 655303 Dallas, Texas 75265 Web Site: http://www.ti.com	SLLS177E
3.3V-5V 256Kbit (32Kx8) Timekeeper SRAM ST Microelectronics 1000 East Bell Road Phoenix, AZ 85022 Web Site: http://eu.st.com/stonline/index.shtml	M48T37V
2-Wire Serial CMOS EEPROM Atmel Corporation San Jose, CA Web Site: http://www.atmel.com/atmel/support/	AT24C02 AT24C04 AT24C64 AT24C256 AT24C512
Universe II User Manual Tundra Semiconductor Corporation Web Site: http://www.tundra.com/page.cfm?tree_id=100008#Universe II (CA91C042)	8091142_MD300_01.pdf

Related Specifications

For additional information, refer to the following table for related specifications. For your convenience, a source for the listed document is also provided. It is important to note that in many cases, the information is preliminary and the revision levels of the documents are subject to change without notice.

Table B-3. Related Specifications

Document Title and Source	Publication Number
VITA http://www.vita.com/	
VME64 Specification	ANSI/VITA 1-1994
VME64 Extensions	ANSI/VITA 1.1-1997
2eSST Source Synchronous Transfer	VITA 1.5-199x
PCI Special Interest Group (PCI SIG) http://www.pcisig.com/	
Peripheral Component Interconnect (PCI) Local Bus Specification, Revision 2.0, 2.1, 2.2	PCI Local Bus Specification

B

block diagram [1-4](#)

C

cache [2-16](#)
comments, sending [xiv](#)
config switch register [1-17](#)
conventions used in the manual [xiv](#)
core frequency [2-16](#)
CPU bus mode [2-15](#)

D

default PCI memory map [1-7](#)
default processor memory map [1-5](#)
documentation, related [B-1](#)

F

features [1-2](#)
Flash memory [2-14](#)
 config data [A-1](#)

G

geographical address register [1-18](#)
GT-64260B system controller [2-1](#)
 device bank timing [2-12](#)
 device controller banks [2-11](#)
 GPP config [2-7](#)
 GPP interrupts [2-4](#)
 I2C [2-5](#)
 initialization [2-7](#)
 interrupt controller [2-3](#)
 power-up config [2-10](#)
 reset config [2-9](#)

I

I2C [2-5](#)
IDSEL mapping [2-2](#)

interrupt controller [2-3](#)

L

L1, L2, L3 cache [2-16](#)
L3 cache config data [A-3](#)

M

manual conventions [xiv](#)
manufacturers' documents [B-2](#)
memory maps
 default PCI [1-7](#)
 default processor [1-5](#)
 MOTLoad's PCI [1-9](#)
 MOTLoad's processor [1-6](#)
 system I/O [1-10](#)
MOTLoad's PCI memory map [1-9](#)
MOTLoad's processor memory map [1-6](#)

N

NVRAM [1-20](#)

P

PCI arbiter [2-15](#)
PLL clock generators [2-13](#)
presence detect register [1-16](#)
processor bus mode [2-15](#)
processor version register [2-16](#)

R

real-time clock [1-20](#)
registers
 config switch register [1-17](#)
 geographical address register [1-18](#)
 presence detect register [1-16](#)
 system status register 1 [1-11](#)
 system status register 2 [1-13](#)
 system status register 3 [1-15](#)

time base enable register [1-18](#)
related documentation [B-1](#)

S

suggestions, submitting [xiv](#)
system clock generators [2-13](#)
system I/O memory map [1-10](#)
system status register 1 [1-11](#)
system status register 2 [1-13](#)
system status register 3 [1-15](#)

T

temp sensor [2-14](#)

time base enable register [1-18](#)
two-wire serial interface [2-5](#)
typeface, meaning of [xiv](#)

U

UART [1-20](#)

V

vital product data (VPD) [2-14](#), [A-1](#)
 Flash memory [A-1](#)
 L3 cache [A-3](#)