

## Dual PMC Carrier Board

### Key Features

AD CR5/PMC consists of a Carrier Board with two PMC sites and a host adapter board that can be used with a range of Concurrent Technologies' VME boards.

- Supports two single size or one double size PMC Module
- Includes host adapter board that fits on a vacant PMC site of the VME host card
- Includes interconnecting cable
- PMC I/O is available on the front panel or on the backplane connectors via configuration blocks
- Versions available for extended operating temperature

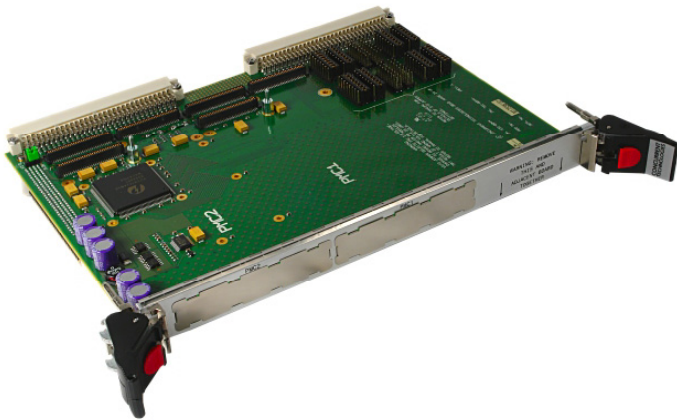
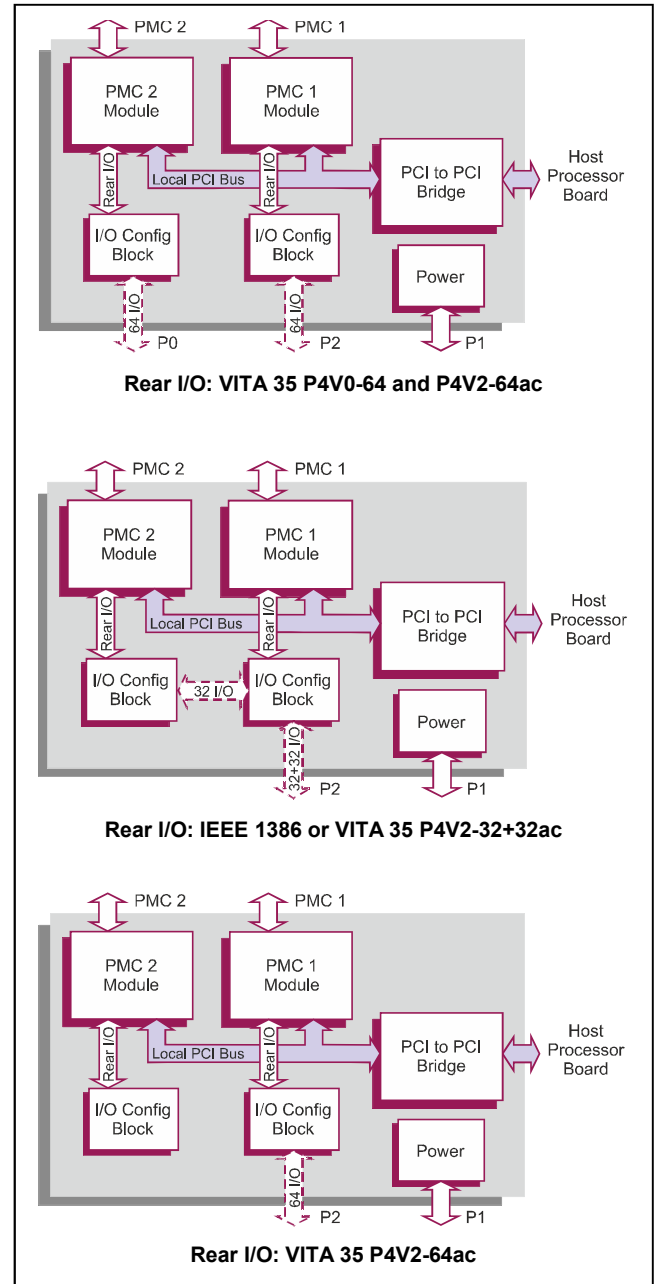

## Dual PMC Carrier Board

- support for 2 single width modules or one dual width module:
  - 5 Volt or 3.3 Volt signaling
  - 32-bit, 33MHz local PCI bus
  - supports dual function modules
  - supports non-Monarch Processor PMC modules
- complies with CMC (Common Mezzanine Card) standard IEEE 1386-2001 and PMC (PCI Mezzanine Card) standard IEEE 1386.1-2001
- I/O is accessible via the front panel, P2 connector and optional P0 connector:
  - 64 or 32+32 I/O signals via P2 connector
  - 64 I/O signals via P0 connector
  - I/O pin mapping compliant with IEEE 1386 and with VITA 35 PMC I/O wiring standards
  - I/O signals routed as differential pairs
- I/O is user configurable with jumper blocks
- I/O is compatible with the popular AD CR2/PMC

## Adaptor Interface

- connects to a compatible VME PMC host processor board:
  - implemented using the Pericom PI7C8152A PCI to PCI bridge
  - 32-bit, 33MHz PCI interface
- utilizes PCI 2.2 Local Bus Specification
- utilizes PCI to PCI Bridge Specification 1.1

## Compatible VME PMC Host Boards

- contact your local sales office for the latest range of boards supported.

## Software Support

- adaptor interface features a standard PCI to PCI bridge:
  - PMC modules appear on the additional PCI bus
- Operating System support depends upon the Concurrent Technologies PMC host processor board

## Electrical Specification

- +5V @ 0.5A maximum (excluding PMC modules)
- +12V @ 0.0A; -12V @ 0.0A; 3.3V not required
- +12V and -12V routed to both PMC sites

## Environmental Specification

- operating temperatures:
  - 0°C to +55°C (N-Series)
  - -25°C to +70°C (E-Series)
  - -40°C to +85°C (K-Series)
- non-operating temperature: -40°C to +85°C
- 5% to 95% Relative Humidity, non condensing
  - K-Series includes humidity sealant

## Mechanical Specification

- 6U form-factor
- single slot, front panel width 0.8-inch (20.3mm)
- utilizes 96-way connectors for P1 and P2
- optional P0
- shock: 20g, 11ms, sine
- vibration: 5Hz-2000Hz at 2g, 0.38mm peak displacement