

# MVME3100

## NXP® MPC8540 VME SBC

### DATA SHEET

***The MVME3100 single-board computer (SBC) gives additional performance while protecting your investment***

- System-on-chip NXP MPC8540 with PowerPC® e500 processor core, integrated memory controller, DMA engine, PCI-X interface, Ethernet and local I/O
- Two Gigabit Ethernet ports plus an additional 10/100BaseTX port
- Up to 512MB of DDR333 ECC memory
- USB 2.0 and Serial ATA controllers for integrating cost-effective peripherals
- 2eSST VMEbus protocol offering interoperability with products such as the MVME6100 at higher bandwidths
- Dual 33/66/100MHz PMC-X sites for expansion via industry standard modules, support for processor PMCs and PMCspan
- MVME721 direct-connect rear transition module (RTM) for I/O routing through rear of compact VMEbus chassis

The SMART Embedded Computing MVME3100, featuring the system-on-chip NXP MPC8540 processor, offers a growth path for VMEbus customers with applications on the previous generation of VME, specifically the MPC8240 and similar (MPC603 family) processors.

The system-on-chip implementation offers power/thermal, reliability, and lifecycle advantages not typically found in alternative architectures. The faster processor and 2eSST VMEbus interface combine to offer significant performance improvement.

OEMs of industrial, medical, and defense/aerospace VMEbus platforms can now add performance and features for competitive advantage while still protecting their fundamental investment in VMEbus and related technologies. Customers can keep their VMEbus infrastructure (chassis, backplanes, and other VMEbus and PMC boards) while improving performance and extending the lifecycle. Also, the extended lifecycle of SMART EC computing products helps reduce churns in development and support efforts resulting from frequent product changes.

New cost-effective peripherals can be integrated easily using USB and Serial ATA interfaces. SATA represents a significant cost reduction opportunity from older SCSI technology, with generally lower drive pricing for equivalent capacity.

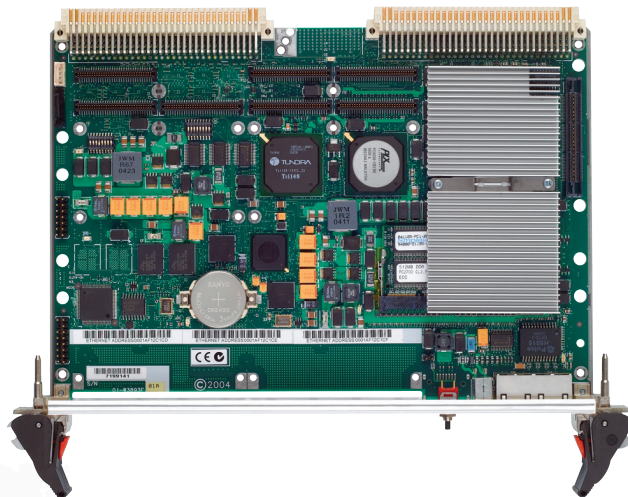

**powerBridge**  
Computer

Ehlbeek 15a  
30938 Burgwedel  
fon 05139-9980-0 info@powerbridge.de  
fax 05139-9980-49 www.powerbridge.de

**SMART**  
Embedded Computing



**MVME3100 Block Diagram**

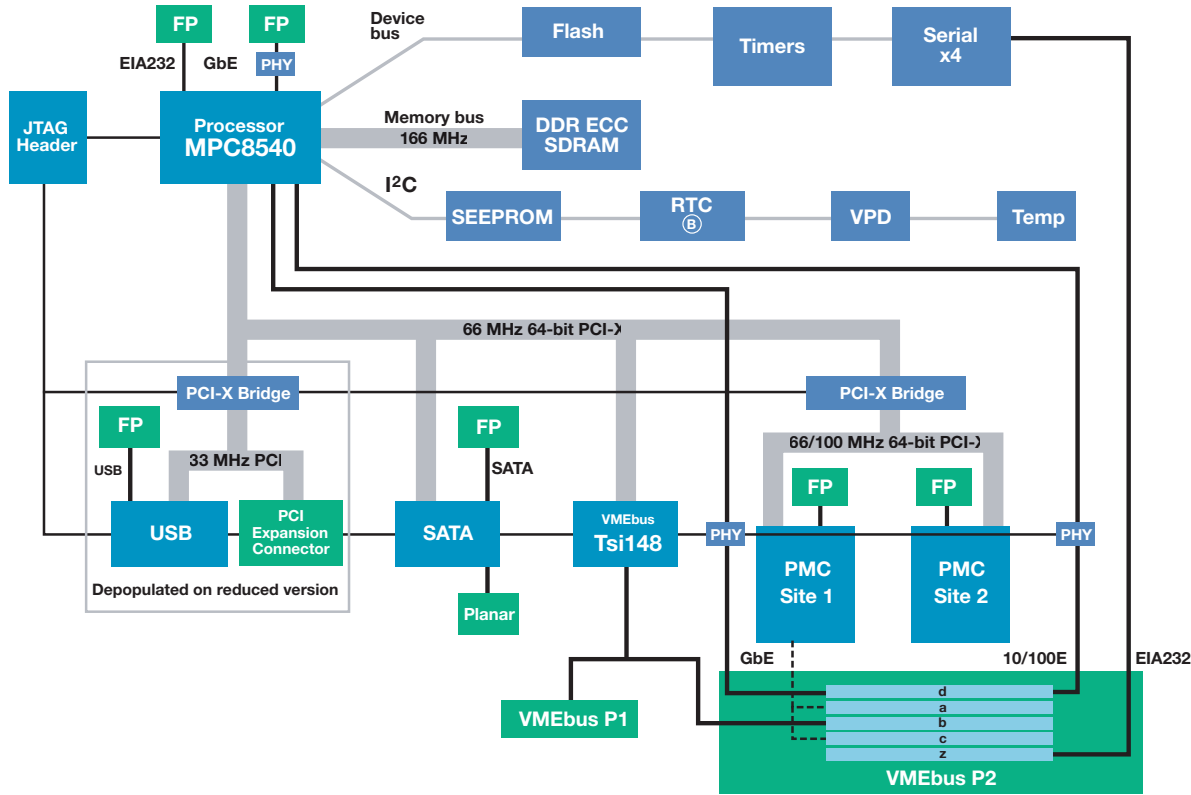

**Overview**

**VMEBUS 2ESST PERFORMANCE**

The 2eSST protocol offers an available VME bus bandwidth of up to 320MB/s, an increase of up to 8x over VME64, while maintaining backward compatibility with VME64 and VME32. The combination of the latest Texas Instruments VMEbus transceivers and the Tundra Tsi148 VMEbus bridge’s legacy protocol support allows customers to integrate the MVME3100 series into their existing infrastructure providing backward compatibility and thereby preserving their investment in existing VMEbus boards, backplanes, chassis and software.

**BALANCED PERFORMANCE**

The MVME3100 series provides more than just faster VMEbus transfer rates; it provides balanced performance from the processor, memory subsystem, local buses and I/O subsystems. This coupled with a wealth of I/O interfaces make the MVME3100 series ideal for use as an application-specific compute blade, or an intelligent I/O blade/carrier. The NXP MPC8540 system-on-chip (SoC) processor, running at speeds up to 833 MHz, is well-suited for I/O and data-intensive applications.

The integrated SoC design creates an I/O intensive state-of-the-art package that combines a low power processing core and on-chip L2 cache with integrated controllers for memory, PCI-X, DMA , Ethernet and local device I/O. The on-chip PCI-X bus and a 166 MHz DDR memory bus are well matched to the processor. To ensure that the MVME3100 series can handle the 320MB/s data rates of 2eSST, the Tsi148 VMEbus interface chip is directly connected to the integrated PCI-X bus at 66 MHz. A secondary PCI-X bus has dual PMC-X sites—each site supports PMC or PMC-X cards supporting PCI bus speeds from 33 to 100 MHz. The MVME3100 also offers dual Gigabit Ethernet interfaces, a 10/100 interface, USB 2.0, dual Serial ATA ports, and five (5) RS232 serial connections. All of this adds up to a set of well-balanced subsystems offering unparalleled performance.



## Backward Compatibility

The MVME3100 series continues the direction of providing a migration path from SMART EC's embedded controllers such as the MVME16x, MVME17x, MVME2300/MVME2400, and from SMART EC SBCs such as the MVME2600/2700 to a single platform. The MVME3100 series, like the MVME5100, MVME5500, and MVME6100 series, merged the best features of SMART EC's embedded controllers and SBCs enabling OEMs to support varying I/O requirements with the same base platform, simplifying part number maintenance, technical expertise requirements, and sparing.

The MVME3100 series offers customers an alternate migration path from the 68 K, MVME2100, MVME2300, MVME2400, MVME2600, MVME2700, and MVME5100 boards to allow them to take advantage of features such as the integrated MPC8540 SoC processor, DDR memory, Gigabit Ethernet, PCI-X, USB, SATA, and 2eSST.

### PCI EXPANSION

The MVME3100 has a 32/64-bit, 33 MHz PCI connection to support PCI expansion carriers such as the SMART EC PMCspan.

### TRANSITION MODULES

The MVME721 transition module provides industry standard connector access to one 10/100/1000BaseTx port. All of these are via RJ45 connectors. The MVME721 RTM is designed to directly connect to the VME backplane in chassis' with an 80 mm deep rear-transition area.

## Software Support

### FIRMWARE MONITOR

The MVME3100 firmware (known as MOTLoad) is resident in the MVME3100 flash and provides poweron self-test initialization and operating system booting capabilities. In addition, it provides a debugger interface similar to the time proven "BUG" interface on previous VMEbus boards from SMART EC.

### OPERATING SYSTEMS AND KERNELS

The MVME3100 series supports booting a variety of Linux operating systems.

## Specifications

### PROCESSOR

- Microprocessor: NXP MPC8540 PowerQUICC III – PowerPC e500 core
- Clock Frequency: 667 or 833 MHz
- On-chip L1 Cache (I/D): 32 K/32 K
- On-chip L2 Cache: 256 KB look-aside

### SYSTEM CONTROLLER

- Integrated within MPC8540

### MAIN MEMORY

- Type: Double data rate (DDR1) ECC SDRAM
- Speed: DDR333 (166 MHz)
- Capacity: Up to 512MB SO-DIMM
- Configurations: One single-bank module; 256MB or 512MB

### FLASH MEMORY

- Type: Flash, on-board programmable
- Capacity: 64MB or 128MB soldered flash options
- Write Protection: Hardware via switch, software via register or sector lock

### NON-VOLATILE MEMORY

- Type: SEEPROM, on-board programmable
- Capacity: 128 KB (available for users), 8 KB baseboard Vital Product Data (VPD)

### VMEBUS INTERFACE

- Compliance: ANSI/VITA 1-1994 VME64 (IEEE STD 1014), ANSI/VITA 1.1-1997 VME64 Extensions, VITA 1.5-199x 2eSST
- Controller: Tundra Tsi148 PCI-X to VMEbus bridge with support for VME64 and 2eSST protocols
- DTB Master: A16, A24, A32, A64; D08-D64, SCT, BLT, MBLT, 2eVME, 2eSST
- DTB Slave: A16, A24, A32, A64; D08-D64, SCT, BLT, MBLT, 2eVME, 2eSST, UAT
- Arbiter: RR/PRI
- Interrupt Handler/Generator: IRQ 1-7/Any one of seven IRQs
- System Controller: Yes, switchable or auto detect
- Location Monitor: Two, LMA32

### ETHERNET INTERFACES

- Controller: MPC8540 Triple Speed (TSEC) and Fast (FEC) Ethernet Controllers
- Interface Speed: Two @ 10/100/1000 Mbps (TSEC), one @ 10/100/Mbps (FEC)
- Connector: One Gigabit Ethernet port routed to front panel RJ-45, one Gigabit Ethernet port and one 10/100 port routed to VMEbus P2 connector, pin out matching MVME721 RTM
- Indicators: Link status/speed/activity



### ASYNCHRONOUS SERIAL PORTS

- Port 1
  - Controller: MPC8540 Duart (second port N/C)
  - Number of Ports: One 16550 compatible
  - Configuration: EIA-232 DTE (Rx/D, Tx/D, RTS, CTS)
  - Async Baud Rate, bps max.: 38.4 K EIA-232, 115 Kbps raw
  - Connector: One front panel RJ-45
- Ports 2-5
  - Controller: Exar ST16C544D Quart
  - Number of Ports: Four 16550 compatible
  - Configuration: EIA-232 (Rx/D, Tx/D, RTS, CTS)
  - Async Baud Rate, b/s max: 38.4 K EIA-232, 115 Kbps raw
  - Connector: Via VMEbus P2 connector, pinout matching MVME721 RTM
- USB Interface
  - Controller: NEC  $\mu$ 720101
  - Configuration: USB 2.0
  - Number of ports: One
  - Connector: One powered port routed to front panel
- Serial ATA Interface
  - Controller: Intel<sup>®</sup> G31244
  - Configuration: 1.5 Gbps/port, Legacy or DPA mode (switch-selected)
  - Number of Ports: Two
  - Connectors: One routed to front panel, one header (+ power) on board top surface
  - Indicators: Planar activity LEDs on board back side

### DUAL IEEE P1386.1 PCI MEZZANINE CARD SLOTS

- Address/Data: A32/D32/D64, PMC PN1, PN2, PN3, PN4 connectors (PN4 for PMC1 only)
- PCI Bus Clock: 33 MHz, 66 MHz or 100 MHz PCI/PCI-X
- Signaling: 3.3 V, 5 V tolerant
- Power: +3.3 V, +5 V,  $\pm$ 12 V
- Module Types: Two single-wide or one double-wide, front panel or P2 I/O, PMC and PrPMC support, PMC1 site Pn4 routed to VMEbus P2 connector rows A and C

### PCI EXPANSION CONNECTOR FOR INTERFACE TO PMCSpan BOARDS

- Address/Data: A32/D32/D64
- PCI Bus Clock: 33 MHz
- Signaling: 5 V
- Power: +3.3 V, +5 V,  $\pm$ 12 V
- Connector: One 114-pin connector located on MVME3100 planar, same location as on MVME5500 planar

### COUNTERS/TIMERS

- TOD Clock Device: Maxim DS1375 I<sup>2</sup>C device with battery backup
- Cell Storage Life: 10 years at 25 °C
- Cell Capacity Life: One year at 100% duty cycle, 25 °C
- Removable Battery: Yes
- Real-Time Timers/Counters: Four, 32-bit programmable timers in PLD; four, 32-bit programmable/ cascadable timers in MPC8540
- Watchdog Timer: Internal to MPC8540. Second level time-out can generate reset

### BOARD SIZE AND WEIGHT

- Height: 233.4 mm (9.2 in.)
- Depth: 160.0 mm (6.3 in.)
- Front Panel Height: 261.8 mm (10.3 in.)
- Width: 19.8 mm (0.8 in.)
- Max. Component Height: 14.8 mm (0.58 in.)
- Weight: 468 g/16.5 oz. (IEEE handles)

### POWER REQUIREMENTS

(Not including power required by PMC or IPMC modules)

	+5 V $\pm$ 5%
MVME3100	4.5 A typ., 5.6 A max.

### CALCULATED MTBF

Estimate to be provided when available.

### OTHER FEATURES

- Jumper-less configuration
- On-board temperature sensor (Maxim DS1621)
- JTAG header for connection of diagnostic tools

### FRONT PANEL

- IEEE handles
- Connectors for serial, Gigabit Ethernet, USB, and SATA ports
- Openings for PMC sites



## Transition Modules

### I/O CONNECTORS

- MVME721
  - Asynchronous Serial Ports: Four, RJ-45, labeled as COM2-5
  - Ethernet: One 10/100/1000BaseTX and one 10/100BaseTX, RJ-45

### NON-VOLATILE STORAGE

- 8 KB VPD SEEPROM

### BOARD SIZE

- Height: 233.4 mm (9.2 in.)
- Depth: 80.0 mm (3.1 in.)
- Front Panel Height: 261.8 mm (10.3 in.)
- Front Panel Width: 19.8 mm (0.8 in.)

## All Modules

### ENVIRONMENTAL

	Operating	Non-operating
Temperature	0 °C to +55 °C (inlet air temp. with forced air cooling)	-40 °C to +85 °C
Humidity (NC)	5% to 90%	5% to 90%
Vibration		1 G RMS, 5 - 100 Hz sine 2 G RMS, 15 - 2000 Hz sine 0.01 g <sup>2</sup> /Hz (4.5 GRMS) 15 - 2000 Hz random
Shock		20 G peak (half sine) 11 ms

### ELECTROMAGNETIC COMPATIBILITY (EMC)

- Intended for use in systems meeting the following regulations:
  - U.S.: FCC Part 15, Subpart B, Class A (non-residential)
  - Canada: ICES-003, Class A (non-residential)
- SMART EC board products are tested in a representative system to the following standards:
  - CE Mark per European EMC Directive 89/336/EEC with Amendments; Emissions: EN55022 Class A; Immunity: EN55024

### SAFETY

All printed wiring boards (PWBs) are manufactured with a flammability rating of 94V-0 by UL recognized manufacturers.

## Ordering Information

Part Number	Description	Weight
MVME31006E-1152	667 MHz MPC8540 processor, 256MB DDR SDRAM, 64MB flash, Gigabit Ethernet, SATA, IEEE handles, 6E	0.44 kg
MVME31006E-1263	833 MHz MPC8540 processor, 512MB DDR SDRAM, 128MB flash, Gigabit Ethernet, SATA, USB, PCI expansion connector, IEEE handles, 6E	0.45 kg

### Related Products

PMCSPAN26E-002	Primary PMCSPAN with IEEE ejector handles, 6E
PMCSPAN26E-010	Secondary PMCSPAN with IEEE ejector handles, 6E
MVME7216E-101	RTM, NEW I/O ON 5 ROW P2, 2 GIGE, 4 SERIAL, PIM, 6E (FOR USE WITH MVME250x/3100/7100/4100)

## SOLUTION SERVICES

SMART Embedded Computing provides a portfolio of solution services optimized to meet your needs throughout the product lifecycle. Design services help speed time-to-market. Deployment services include worldwide technical support. Renewal services enable product longevity and technology refresh.

## CONTACT DETAILS

+1 602-438-5720

[Info@smartembedded.com](mailto:Info@smartembedded.com)

[www.smartembedded.com/ec/contact](http://www.smartembedded.com/ec/contact)

The stylized "S" and "SMART", and the stylized "S" combined with "SMART" and "Embedded Computing" are trademarks of SMART Modular Technologies, Inc. NXP and QorIQ are trademarks of NXP B.V. All other trademarks and registered trademarks are the property of their respective companies. ©2020 SMART Embedded Computing, Inc. Specifications are subject to change without notice. All rights reserved. For full legal terms and conditions, please visit [www.smartembedded.com/ec/legal](http://www.smartembedded.com/ec/legal)

