

# MVME5500

## NXP® MPC7457 VME SBC

### DATA SHEET

*The MVME5500 is the flagship of our VME product line that enables higher levels of performance in a single VMEbus slot*

- MPC7457 PowerPC® processor at 1GHz
- 512 KB of on-chip L2 cache and 2MB of L3 cache
- AltiVec coprocessor for high-performance computational applications
- Two banks of soldered flash memory (32MB and 8MB)
- Dual independent 64-bit PCI buses and PMC sites with a bus speed of up to 66 MHz
- Gigabit Ethernet interface plus an additional 10/100BaseTX Ethernet interface
- 64-bit PCI expansion mezzanine connector allowing up to four more PMCs
- I/O compatibility with MVME51xx family
- Support for processor PMCs (PrPMCs)



The MVME5500 from SMART Embedded Computing uses the MPC7457 processor running at 1 GHz, balanced with memory, dual independent local buses and I/O subsystems.

The powerful Marvell system controller, with support for a 133 MHz host bus and a 133 MHz SDRAM memory bus, is well matched to the high speed processor.

To match the system I/O to the outstanding processor performance, the MVME5500 provides dual 64-bit, 33/66 MHz PCI buses. Each PCI bus has a PMC site supporting cards running at 33 or 66 MHz. The Universe II VME interface and PMCspan connector are isolated from the PMC sites on a dedicated 33 MHz PCI bus segment so that both PMC sites are capable of 66 MHz operation.

The MVME5500 also offers a Gigabit Ethernet interface, a 10/100BaseTX Ethernet interface and two serial ports. All of this adds up to a set of well-balanced, high-performance subsystems for unparalleled performance.

The MVME5500 series is designed to meet the needs of OEMs including those in defense and aerospace, industrial automation and transportation. Customers looking for a technology refresh for their application while maintaining backward compatibility with their existing VMEbus infrastructure can upgrade to the MVME5500 series and take advantage of the enhanced performance features.

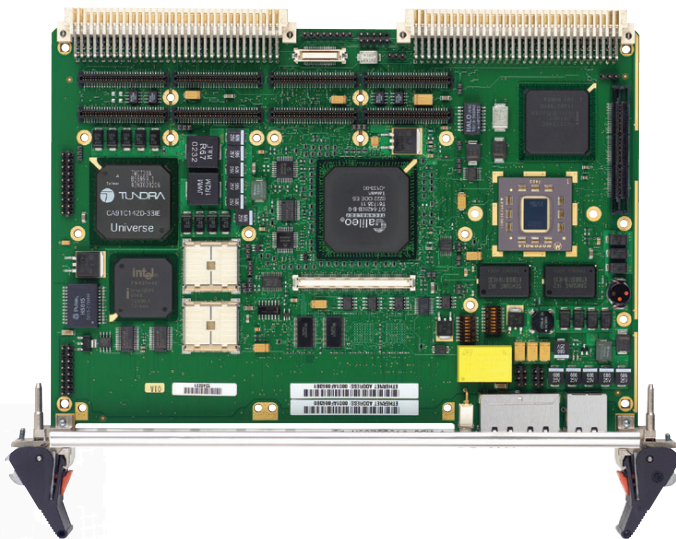

**powerBridge**  
Computer

Ehlbeek 15a  
30938 Burgwedel  
fon 05139-9980-0  
fax 05139-9980-49  
info@powerbridge.de  
www.powerbridge.de

 **SMART**  
Embedded Computing



**MVME5500 Block Diagram**

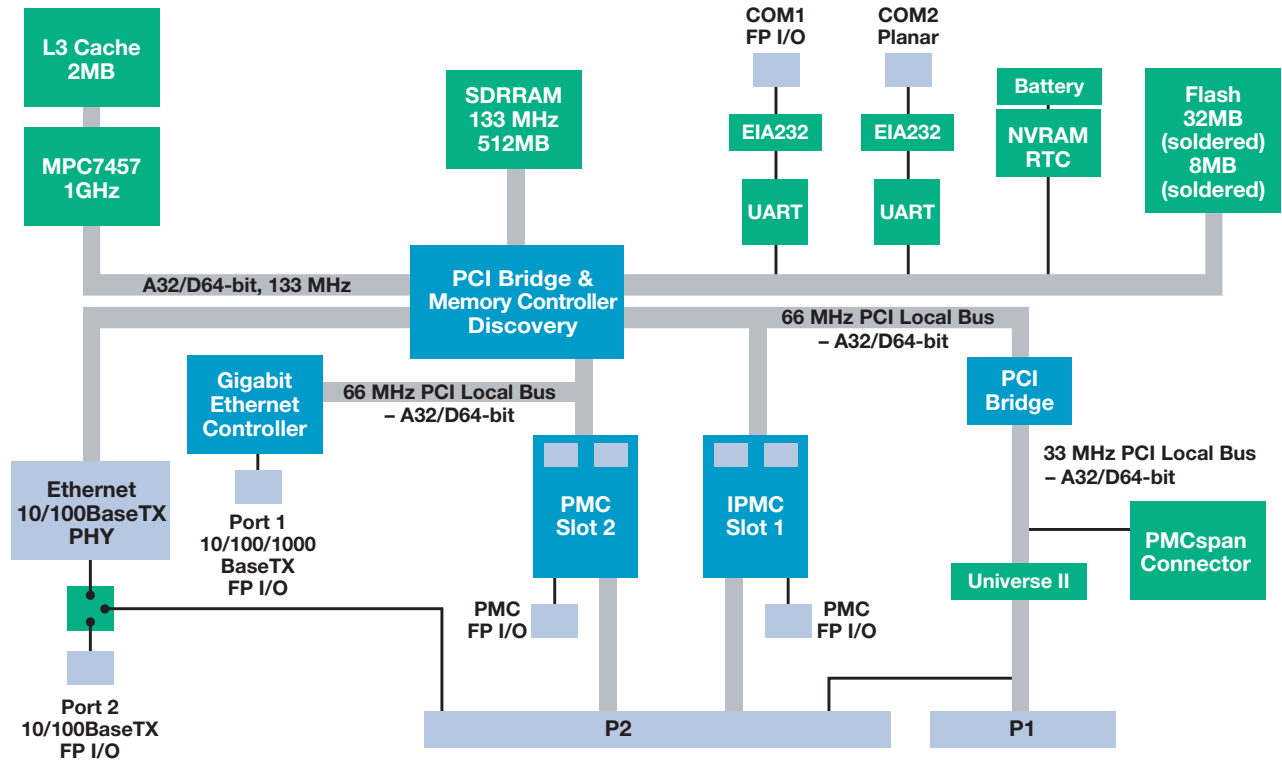

**Backwards Compatibility**

The MVME5500 continues the direction that SMART EC started with the MVME5100 series of providing a migration path from SMART EC's embedded controllers and single-board computers (SBCs) to a single platform. This migration path enables OEMs to support varying I/O requirements with the same base platform, simplifying part number maintenance, technical expertise requirements and sparing.

The MVME5500 series offers customers a migration path from the MVME2300, MVME2400, MVME2600, MVME2700 and MVME5100 boards to allow them to take advantage of features such as the MPC7455 processor, Gigabit Ethernet and dual independent 33/66 MHz PMC sites.



### TRANSITION MODULES

The **MVME761** transition module provides industry standard connector access to the IEEE 1284 parallel port, a 10BaseT or 100BaseT port via an RJ-45 connector, two DB-9 connectors providing access to the asynchronous serial ports configured as EIA-574 DTE and two HD-26 connectors providing access to the sync/async serial ports. These serial ports, labeled as Serial 3 and Serial 4 on the faceplate of the MVME761, are individually user-configurable as EIA-232, DCE or DTE via the installation of SMART EC Serial Interface Modules (SIMs). A P2 adapter board provides interface signals to the MVME761 transition module. Two separate P2 adapter boards are available: one for 3-row backplanes and one for 5-row backplanes. The 3-row P2 adapter board provides connection for 8-bit SCSI. A 5-row P2 adapter board supports 16-bit SCSI and PMC I/O.

### Software Support

#### FIRMWARE MONITOR

Firmware must fulfill the traditional functions of power-on self-test (POST), initialization, low-level setup and debug, and operating system booting. SMART EC's innovative firmware (known as MOTLoad) that is resident on the MVME5500 exceeds these requirements with expanded features such as interrupt driven I/O, more comprehensive power-up tests and extensive diagnostics with new scripting capability. And of course, MOTLoad provides a debugger interface similar to the time proven "bug" interface on previous VMEbus boards from SMART EC.

#### OPERATING SYSTEMS AND KERNELS

VxWorks (available through Wind River)

### Specifications

#### PROCESSOR

- Microprocessor: MPC7457
- Clock Frequency: 1GHz
- On-chip L1 Cache (I/D): 32 KB/32 KB
- On-chip L2 Cache (I/D): 512 KB
- L3 Cache: 2MB

#### SYSTEM CONTROLLER

- Marvell GT-64260B

#### MAIN MEMORY

- Type: PC133 ECC SDRAM
- Speed: 133 MHz
- Configurations: 512 MB in two banks

#### FLASH MEMORY

- Type: EEPROM, on-board programmable
- Capacity: 40MB total in two banks of 32MB and 8MB, both soldered
- Write Protection: 32MB of surface-mount flash is write protectable via jumper

#### NVRAM

- Capacity: 32 KB (4 KB available for users)
- Cell Storage Life: 50 years at 55 °C
- Cell Capacity Life: Five years at 100% duty cycle, 25 °C
- Removable Battery: Yes

#### COUNTERS/TIMERS

- TOD Clock Device: M48T37V
- Real-Time Timers/Counters: Eight, 32-bit programmable
- Watchdog Timer: Time-out generates reset

#### VMEBUS INTERFACE: ANSI/VITA 1-1994 VME64 (IEEE STD 1014)

- Controller: Tundra Universe II
- DTB Master: A16-A32; D08-D64, SCT, BLT
- DTB Slave: A24-A32; D08-D64, BLT, UAT
- Arbiter: RR/PRI
- Interrupt Handler/Generator: IRQ 1-7/Any one of seven IRQs
- System Controller: Yes, jumperable or auto detect
- Location Monitor: Two, LMA32



### ETHERNET INTERFACES

- Port 1
  - Controller: Intel® 82545GM Gigabit Ethernet controller.
  - Interface Speed: 10/100/1000 Mbps
  - Connector: Routed to front panel RJ-45
- Port 2
  - Controller: Controller integrated into GT-64260B system controller
  - Interface Speed: 10/100 Mbps
  - Connector: Routed to front panel RJ-45 or optionally routed to P2, RJ-45 on MVME761

### ASYNCHRONOUS SERIAL PORTS

- Controller: Two TL16C550C UARTs
- Number of Ports: Two, 16550 compatible
- Async Baud Rate, bps max.: 38.4 K EIA-232, 115 Kbps raw
- Connector: Routed to front panel RJ-45; one on planar for development use

### DUAL IEEE P1386.1 PCI MEZZANINE CARD SLOTS

- Address/Data: A32/D32/D64, PMC PN1, PN2, PN3, PN4 connectors
- PCI Bus Clock: 33/66 MHz
- Signaling: 3.3 V or 5 V, configurable with keying pin
- Power: +3.3 V, +5 V, ±12 V
- Module Types: Two single-wide or one doublewide, front panel or P2 I/O, PMC and PrPMC support

### PCI EXPANSION CONNECTOR

- Address/Data: A32/D32/D64
- PCI Bus Clock: 33 MHz
- Signaling: 5 V
- Power: +3.3 V, +5 V, ±12 V
- Connector: 114-pin connector located on MVME5500 planar, same location as on MVME5100 planar

### POWER REQUIREMENTS

- 6.7 A typ., 8.0 A max. (+5V ±5%)  
 Note: In a 3-row chassis, PMC current should be limited to 19.8 watts (total of both PMC slots). In a 5-row chassis, PMC current should be limited to 46.2 watts (total of both PMC slots).

### BOARD SIZE

- Height: 233.4 mm (9.2 in.)
- Depth: 160.0 mm (6.3 in.)
- Front Panel Height: 261.8 mm (10.3 in.)
- Width: 19.8 mm (0.8 in.)
- Max. Component Height: 14.8 mm (0.58 in.)

Transition Modules	
I/O Connectors	
	<b>MVME761</b>
<b>Asynchronous Serial Ports</b>	Two, DB-9 labeled as COM1 and COM2
<b>Synchronous Serial Ports</b>	Two, HD-26 labeled as Serial 3 and Serial 4 (user-configurable via installation of SIMs); two 60-pin connectors on MVME761 planar for installation of two SIMs
<b>Parallel Port</b>	HD-36, Centronics compatible
<b>Ethernet</b>	10BaseT or 100BaseT, RJ-45
<b>SCSI</b>	8- or 16-bit, 50- or 68-pin connector via P2 adapter

### BOARD SIZE

- Height: 233.4 mm (9.2 in.)
- Depth: 80.0 mm (3.1 in.)
- Front Panel Height: 261.8 mm (10.3 in.)
- Front Panel Width – MVME761: 19.8 mm (0.8 in.)





## All Modules

### ENVIRONMENTAL

	Operating	Non-operating
Temperature	0 °C to +55 °C (inlet air temp. with forced air cooling*)	-40 °C to +85 °C
Humidity (NC)	5% to 90%	5% to 90%
Vibration		1 G sinusoidal, 5 - 100 Hz 2 axes horizontal and vertical (NEBS1)

\* Reference cooling requirements section of the user's manual.

Note: Conformal coating these products may result in up to a 2 °C reduction in operating temperature limits.

### DEMONSTRATED MTBF

Based on field analysis, estimated MTBF is 796,000 hours at 60% confidence level.

### ESTIMATED MTBF

MTBF estimated per Telcordia SR-332, issue 2, ground fixed, controlled environment, unit ambient air temperature of 40 °C is 702,000 hours. Contact SMART EC for alternative environments or temperatures.

### ELECTROMAGNETIC COMPATIBILITY (EMC)

- Intended for use in systems meeting the following regulations:
  - U.S.: FCC Part 15, Subpart B, Class A (non-residential)
  - Canada: ICES-003, Class A (non-residential)
- SMART EC board products are tested in a representative system to the following standards:
  - CE Mark per European EMC Directive 89/336/EEC with Amendments; Emissions: EN55022 Class A; Immunity: EN55024

### SAFETY

All printed wiring boards (PWBs) are manufactured with a flammability rating of 94V-0 by UL recognized manufacturers.

Ordering Information			
New Part Number	Old Part Number	Description	Weight
MVME55006E-0161R	MVME55006E-0161	1GHz MPC7457 PowerPC processor, 512MB SDRAM, Scanbe handles 6E	0.40 kg
MVME55006E-0163R	MVME55006E-0163	1GHz MPC7457 PowerPC processor, 512MB SDRAM, IEEE handles 6E	0.43 kg
Related Products			
MVME7616E-011	Transition module with two DB-9 async serial port connectors, two HD-26 sync/async serial port connectors, one HD-36 parallel port connector, one RJ-45 10/100 Ethernet connector; includes 5-row DIN P2 adapter board and cable (for 16-bit SCSI); requires backplane with 5-row DIN connectors 5E		
PMCSpan16E-002	Primary PMCSpan-002 with original VME Scanbe ejector handles 5E		
Documentation			
V5500A/IH	MVME5500 Single-Board Computer Installation and Use		
V5500A/PG	MVME5500 Single-Board Computer Programmer's Reference Guide		
VME761A/IH	MVME761 Transition Module Installation and Use		
MOTLODA/UM	MOTLoad Firmware Package User's Manual		
PMCSpanA/IH	PMCSpan PMC Adapter Carrier Board Installation and Use		

## SOLUTION SERVICES

SMART Embedded Computing provides a portfolio of solution services optimized to meet your needs throughout the product lifecycle. Design services help speed time-to-market. Deployment services include worldwide technical support. Renewal services enable product longevity and technology refresh.

## CONTACT DETAILS

+1 602-438-5720

Info@smartembedded.com

www.smartembedded.com/ec/contact

The stylized "S" and "SMART", and the stylized "S" combined with "SMART" and "Embedded Computing" are trademarks of SMART Modular Technologies, Inc. NXP and QorIQ are trademarks of NXP B.V. All other trademarks and registered trademarks are the property of their respective companies. ©2019 SMART Embedded Computing, Inc. Specifications are subject to change without notice. All rights reserved. For full legal terms and conditions, please visit www.smartembedded.com/ec/legal

