

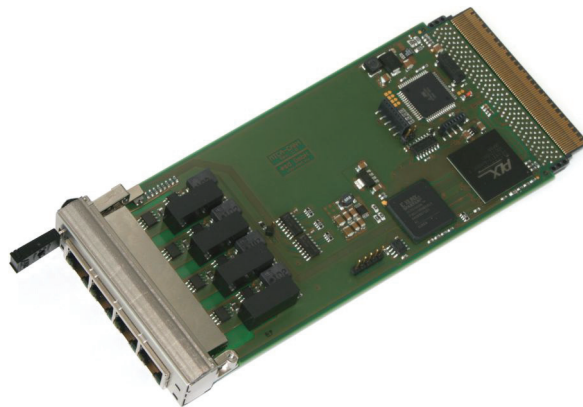

# AMC-CAN4

## 4 Channel AMC CAN Module



### Hardware Manual

to Product U.1002.01



Ehlbeek 15a  
30938 Burgwedel  
fon 05139-9980-0  
fax 05139-9980-49

[www.powerbridge.de](http://www.powerbridge.de)  
[info@powerbridge.de](mailto:info@powerbridge.de)

## NOTE

The information in this document has been carefully checked and is believed to be entirely reliable. **esd** makes no warranty of any kind with regard to the material in this document, and assumes no responsibility for any errors that may appear in this document. In particular descriptions and technical data specified in this document may not be constituted to be guaranteed product features in any legal sense.

**esd** reserves the right to make changes without notice to this, or any of its products, to improve reliability, performance or design.

All rights to this documentation are reserved by **esd**. Distribution to third parties, and reproduction of this document in any form, whole or in part, are subject to **esd**'s written approval.

© 2015 esd electronic system design gmbh, Hannover

esd electronic system design gmbh  
Vahrenwalder Str. 207  
30165 Hannover  
Germany

Phone: +49-511-372 98-0  
Fax: +49-511-372 98-68  
E-Mail: [info@esd.eu](mailto:info@esd.eu)  
Internet: [www.esd.eu](http://www.esd.eu)

### Trademark Notices

CANopen® and CiA® are registered community trademarks of CAN in Automation e.V.  
Windows® is a registered trademark of Microsoft Corporation in the United States and other countries.  
The PICMG® name and logo are registered trademarks of the PCI Industrial Computer Manufacturers Group.

All other trademarks, product names, company names or company logos used in this manual are reserved by their respective owners.

<b>Document file:</b>	I:\Texte\Doku\MANUALS\AMC\AMC-CAN4\AMC-CAN4_Hardware_en_11.odt
<b>Date of print:</b>	2015-03-04
<b>Document type number:</b>	DOC0800

<b>Hardware version:</b>	from FPGA release 0.0.23
--------------------------	--------------------------

## Document History

The changes in the document listed below affect changes in the hardware as well as changes in the description of the facts, only.

Rev.	Chapter	Changes versus previous version	Date
1.0	-	First English version	2011-03-03
1.1	-	Safety Instructions revised	2015-03-04
	-	Typographical Conventions inserted	
	8.	Declaration of Conformity inserted	
	9.	Order Information revised	

Technical details are subject to change without further notice.



## Safety Instructions

- When working with AMC-CAN4 follow the instructions below and read the manual carefully to protect yourself from injury and the AMC-CAN4 from damage.
- The device is a built-in component. It is essential to ensure that the device is mounted in a way that cannot lead to endangering or injury of persons or damage to objects.
- The device has to be securely installed in the control cabinet before commissioning.
- Protect the AMC-CAN4 from dust, moisture and steam.
- Protect the AMC-CAN4 from shocks and vibrations.
- The AMC-CAN4 may become warm during normal use. Always allow adequate ventilation around the AMC-CAN4 and use care when handling.
- Do not operate the AMC-CAN4 adjacent to heat sources and do not expose it to unnecessary thermal radiation. Ensure an ambient temperature as specified in the technical data.
- Do not use damaged or defective cables to connect the AMC-CAN4 and follow the CAN wiring hints in chapter: "Correctly Wiring Electrically Isolated CAN Networks".
- In case of damages to the device, which might affect safety, appropriate and immediate measures must be taken, that exclude an endangerment of persons and domestic animals and property.
- Current circuits which are connected to the device have to be sufficiently protected against hazardous voltage (SELV according to EN 60950-1).
- The AMC-CAN4 may only be driven by power supply current circuits, that are contact protected.  
A power supply, that provides a safety extra-low voltage (SELV or PELV) according to EN 60950-1, complies with this conditions.



### Attention !

#### **Electrostatic discharges may cause damage to electronic components.**

To avoid this, please perform the steps described on page 10 *before* you touch the AMC-CAN4, in order to discharge the static electricity from your body.

### Qualified Personal

This documentation is directed exclusively towards personal qualified in control and automation engineering. The installation and commissioning of the product may only be carried out by qualified personal, which is authorized to put devices, systems and electric circuits into operation according to the applicable national standards of safety engineering.

### Conformity

The AMC-CAN4 is an industrial product and meets the demands of the EU regulations and EMC standards printed in the conformity declaration at the end of this manual.

**Warning:** In a residential, commercial or light industrial environment the AMC-CAN4 may cause radio interferences in which case the user may be required to take adequate measures.

### Intended Use

The intended use of the AMC-CAN4 is the operation as AMC CAN module in a MicroTCA® system. The guarantee given by esd does not cover damages which result from improper use, usage not in accordance with regulations or disregard of safety instructions and warnings.

- The AMC-CAN4 is intended for installation in a MicroTCA system only.
- The operation of the AMC-CAN4 in hazardous areas, or areas exposed to potentially explosive materials is not permitted.
- The operation of the AMC-CAN4 for medical purposes is prohibited.

### Service Note

The AMC-CAN4 does not contain any parts that require maintenance by the user. The AMC-CAN4 does not require any manual configuration of the hardware.

### Disposal

Devices which have become defective in the long run have to be disposed in an appropriate way or have to be returned to the manufacturer for proper disposal. Please, make a contribution to environmental protection.

# Table of contents

1. Overview.....	8
2. PCB View with Connectors.....	9
3. Hardware Installation .....	10
3.1 Front-Panel View.....	11
3.1.1 Front Panel LEDs and Connectors.....	11
3.1.2 LED Indication.....	11
3.1.2.1 Description of the AMC LEDs.....	11
3.1.2.2 Description of the CAN LEDs.....	12
4. Technical Data.....	13
4.1 General Technical Data.....	13
4.2 MicroTCA/AMC Standards.....	13
4.3 CAN Interface.....	14
4.4 Software Support.....	14
5. Interfaces and Connector Assignments.....	15
5.1 CAN.....	15
5.1.1 Connector Assignment RJ45.....	16
5.1.2 CAN via AMC-CAN4-DSUB9-ADAPTER (Optional).....	17
6. Correctly Wiring Electrically Isolated CAN Networks.....	18
6.1 Standards concerning CAN Wiring.....	18
6.2 Light Industrial Environment (Single Twisted Pair Cable).....	19
6.2.1 General Rules.....	19
6.2.2 Cabling.....	20
6.2.3 Termination.....	20
6.3 Heavy Industrial Environment (Double Twisted Pair Cable).....	21
6.3.1 General Rules.....	21
6.3.2 Device Cabling.....	22
6.3.3 Termination.....	22
6.4 Electrical Grounding.....	23
6.5 Bus Length.....	23
6.6 Examples for CAN Cables.....	24
6.6.1 Cable for light industrial Environment Applications (Two-Wire).....	24
6.6.2 Cable for heavy industrial Environment Applications (Four-Wire).....	24
7. CAN Troubleshooting Guide.....	25
7.1 Termination.....	25
7.2 Electrical Grounding.....	26
7.3 Short Circuit in CAN Wiring.....	26
7.4 CAN_H/CAN_L-Voltage .....	26
7.5 CAN Transceiver Resistance Test.....	27
7.6 Support by esd.....	27
8. Declaration of Conformity.....	28
9. Order Information.....	29

---

## Typographical Conventions

Throughout this design specification the following typographical conventions are used to distinguish technical terms.

Convention	Example
File and path names	<code>/dev/null</code> or <code>&lt;stdio.h&gt;</code>
Function names	<code><i>open()</i></code>

The following indicators are used to highlight noticeable descriptions.



**Attention:**

Warnings or cautions to tell you about operations which might have unwanted side effects.



**Note:**

Notes to point out something important or useful.

## Abbreviations

API	Application Programming Interface
CAN	Controller Area Network
CPU	Central Processing Unit
CiA	CAN in Automation
HW	Hardware
I/O	Input/Output
LSB	Least Significant Bit
MSB	Most Significant Bit
n.a.	not applicable
OS	Operating System
SDK	Software Development Kit

# 1. Overview

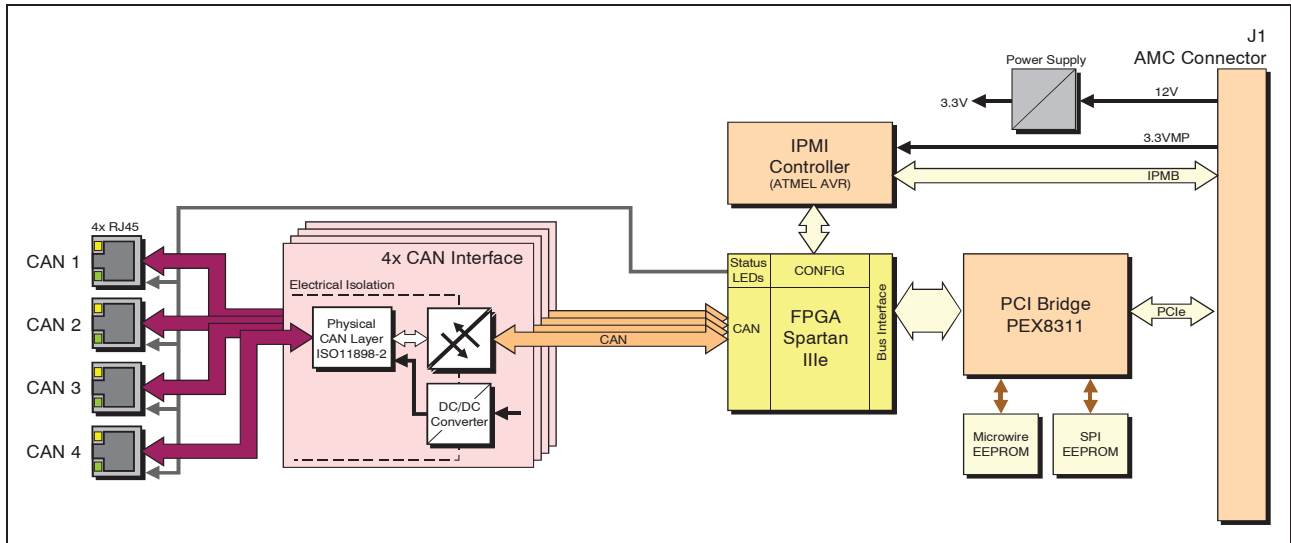

**Figure 1:** Block circuit diagram

The AMC-CAN4 is an AMC CAN module, that features four high-speed CAN interfaces according to ISO 11898-2. The CAN interfaces are electrically isolated against the controller potential and against each other. CAN status is displayed by two LEDs for each CAN channel placed at the RJ45 connectors.

### CAN Data Management

The four independent CAN nets according to ISO 11898-1 are driven by the esd Advanced CAN Core (esdACC) CAN controller implemented in the Xilinx® Spartan® 3e FPGA.

Controlled by the FPGA the AMC-CAN4 supports PCI bus mastering as an initiator, meaning that it is capable of initiating write cycles to the host CPU's RAM independent of the CPU or the system DMA controller. This results in a reduction of overall latency on servicing I/O transactions in particular at higher data rates.

## 2. PCB View with Connectors

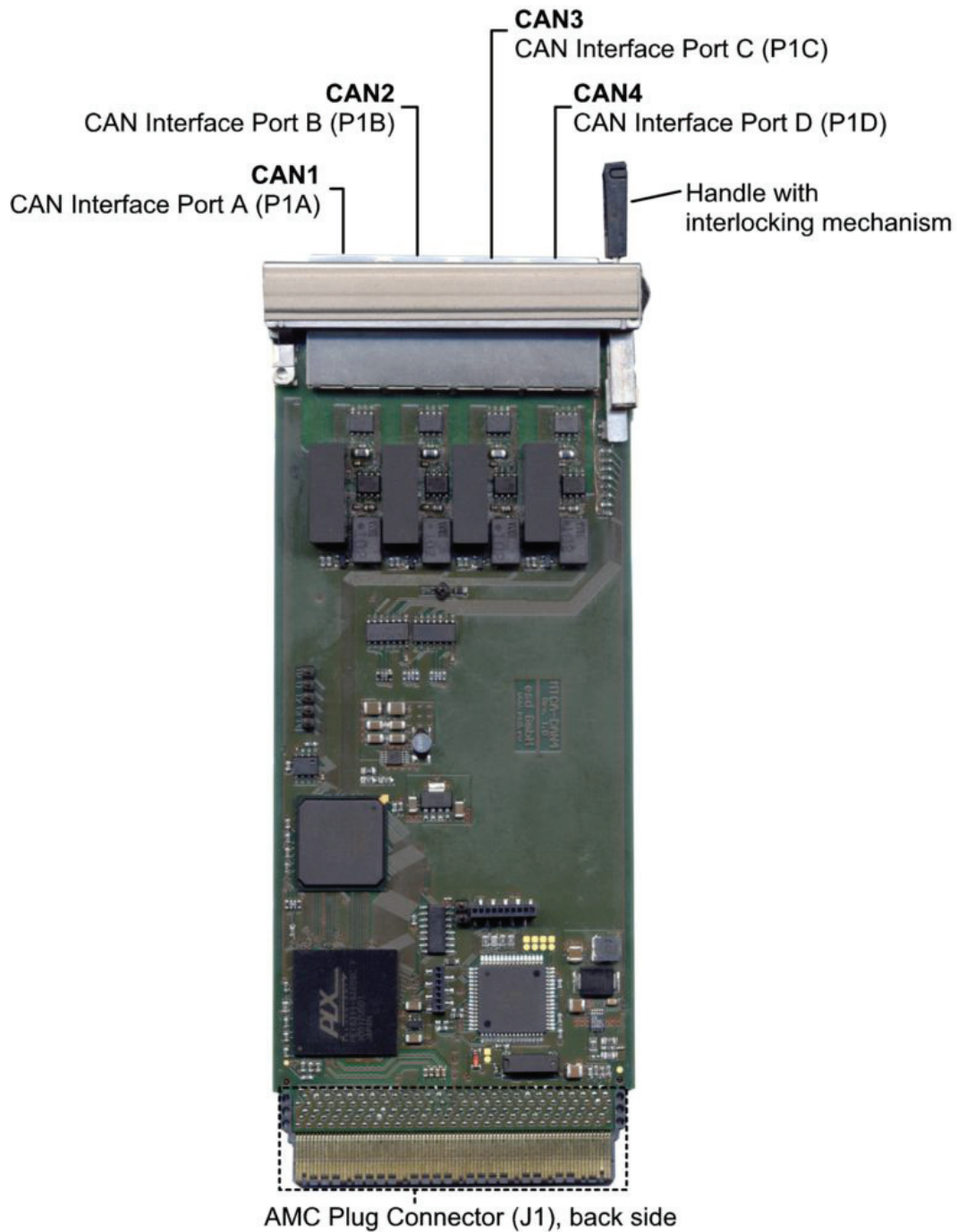

**Figure 2:** PCB top view

See also chapter “Interfaces and Connector Assignments“ from page 15 for signal assignment of the connectors.



### 3. Hardware Installation



**Read the safety instructions at the beginning of this document carefully, before you start with the hardware installation!**



**Attention !**

Electrostatic discharges may cause damage to electronic components. To avoid this, please discharge the static electricity from your body by touching the metal case of the MircoTCA® system *before* you touch the AMC-CAN4.

**Procedure:**

1. The AMC-CAN4 is electrically hot-pluggable.  
Insert the AMC-CAN4 into a free slot in your MicroTCA system.
2. Fix the AMC-CAN4 by pushing the handle with interlocking mechanism (see figure 2).
3. Connect the RJ45 connectors (P1A - P1D) in the front panel (see figure 2) to the CAN bus, e.g. via the optional AMC-CAN-RJ45-DSUB9 cable (see page 29) RJ45 to DSUB9 male.  
Please remember that the CAN bus has to be terminated at both ends.  
esd offers T-connectors and terminators. Additionally, the CAN-GND signal has to be grounded at exactly one point in the CAN network.  
A CAN device whose CAN interface is not electrically isolated corresponds to the grounding of the CAN-GND.
4. End of hardware installation.  
Continue with the software installation as described in the software manual

**'NTCAN-API: Driver Installation Guide'.**

Order Information: NTCAN-API-ME, Order No.: C.2001.21

## 3.1 Front-Panel View

### 3.1.1 Front Panel LEDs and Connectors

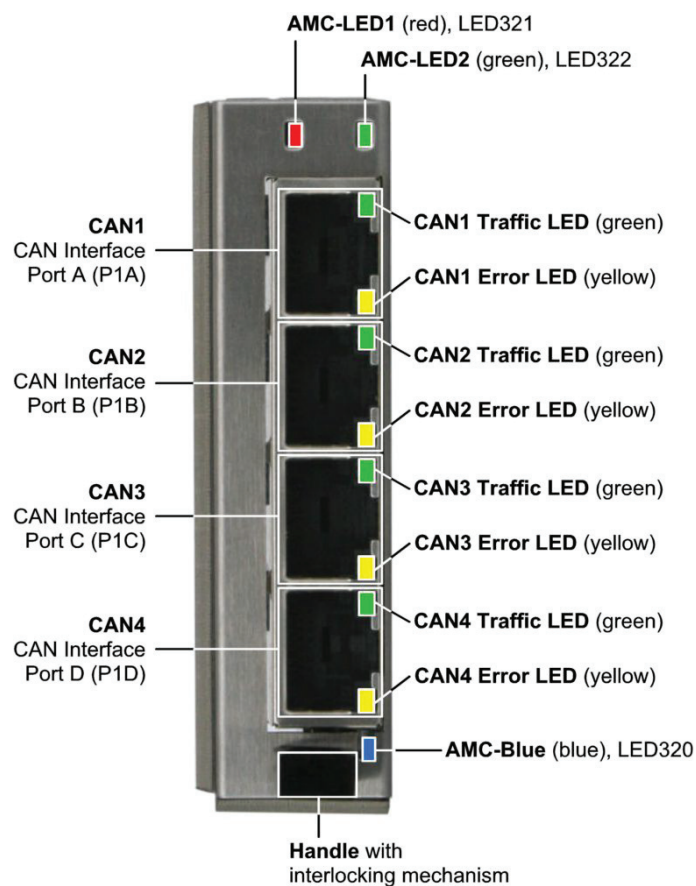

Figure 3: Connectors and LEDs

### 3.1.2 LED Indication

#### 3.1.2.1 Description of the AMC LEDs

The AMC-CAN4 supports 3 AMC LEDs in the front panel (see figure 3).

Name	Colour	Description	LED name in schematics diagram	
AMC-LED1	red	Controlled by IPMI.	LED321	
AMC-LED2	green	Controlled by IPMI. Local function: Lit if FPGA is booted correctly.	LED322	
AMC-Blue	blue	Controlled by IPMI.	LED320	
		Off		in operation
		Blinking		preparing for hot-plug (in transition)
		On	powered off, hot-plug allowed	

Table 1: AMC LEDs

**3.1.2.2 Description of the CAN LEDs**

For each CAN channel (CAN1 ... 4), there are a CAN Traffic LED and a CAN Error LED, integrated in the corresponding RJ45 connector in the front panel of the AMC-CAN4 (see figure 3).

Name	Colour	Description	
CAN Traffic	green	Off	Module not ready for operation
		On	Module ready
		Blinking	CAN Traffic, CAN frames are received or transmitted

**Table 2:** CAN Traffic LED

Name	Colour	Description	
CAN Error	yellow	Off	Bus OK
		On	Bus Off <sup>1)</sup>
		<b>5 Flashes</b> (LED 4x(200 ms on, 200 ms off) + 1x(200ms on, 1000ms off))	Error Passive
		<b>1 Flash</b> (LED 200 ms on, 1000 ms off)	Error Warn

<sup>1)</sup> Depends on CAN driver option.

**Table 3:** CAN Error LED

## 4. Technical Data

### 4.1 General Technical Data

Power supply voltage	nominal voltage: 3.3 V ( $I_{3.3VMPMAX} = 70 \text{ mA}$ ), 12 V ( $I_{12VTYPICAL} = 0.4 \text{ A}$ , $I_{12VMAX} = 0.5 \text{ A}$ )
Connectors	CAN1 ... CAN4 (8 pin RJ45 P1A - D) - 4x CAN Interface  AMC plug connector (170-pin AMC plug connector, J1) - AMC B/B+ compatible (MicroTCA)  Only for test- and programming purposes: X300 programming, debugging  X980 JTAG interface
Temperature range	0...70 °C ambient temperature (free convection)
Humidity	max. 90%, non-condensing
Dimensions	Single Mid-size AdvancedMC Module (73.8x18.96x181.5 mm)
Weight	ca. 140 g

**Table 4:** General data of the module

### 4.2 MicroTCA/AMC Standards

MicroTCA	PICMG® MTCA.0 R1.0, PICMG® AMC.0 R2.0
IPMI	IPMI V1.5
Updates	PICMG® HPM.1 R1.0
PCIe	PCISIG® PCIe spec. R.1.0a, only lane 4 is used
Connector	AMC plug connector according to PICMG® 3.0 Rev. 3.0 AdvancedTCA® Base Specification and PICMG® AMC.1 R2.0 PCI Express on AdvancedMC™

**Table 5:** MicroTCA standards

### 4.3 CAN Interface

Number of CAN interfaces	4
CAN controller	esdACC in FPGA Spartan 3e, acc. to ISO 11898-1 (CAN 2.0 A/B)
CAN protocol	ISO 11898-1
Physical Layer	High-speed CAN interface according to ISO 11898-2, bit rate up to 1 Mbit/s
Electrical isolation	via optocoupler and DC/DC converter, 500 V (effective) between CAN potential and module-system-potential with pollution degree 1
Bus termination	has to be set externally
Connector	4x RJ45, according to DS-303-1

### 4.4 Software Support

CAN layer 2 (CAN-API) software drivers are available for Windows<sup>®</sup>\*, Linux<sup>®</sup>\*, RTX\*, VxWorks<sup>®</sup>\* and QNX<sup>®</sup>\* supporting up to 24 CAN nets. Drivers for other operating systems are available on request.

The CANopen<sup>®</sup> software package is available for Windows\*, Linux\*, RTX\*, VxWorks\* and QNX\*. The J1939 software package is available for Windows\*, Linux\*, VxWorks\* and QNX\*.

\* For detailed information about the driver availability of your special operating system please contact our sales team.

The software installation and the software driver are described in the manual 'NTCAN-API-ME':

Part 1: 'NTCAN-API: Application Developers Manual' and  
Part 2: 'NTCAN-API: Driver Installation Guide'

Order Information: NTCAN-API-ME, Order No.: C.2001.21

## 5. Interfaces and Connector Assignments

### 5.1 CAN

The CAN bus signals are electrically isolated from the other signals via digital isolator and DC/DC-converter.

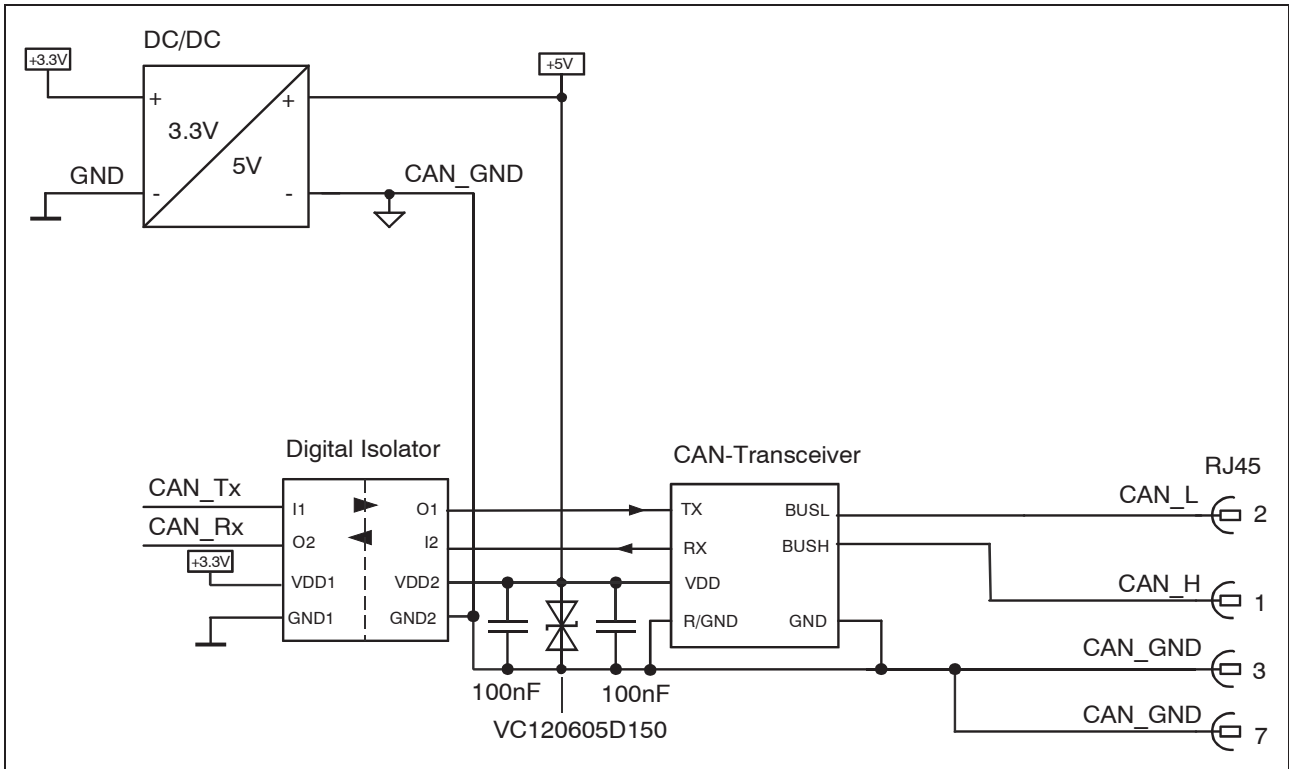
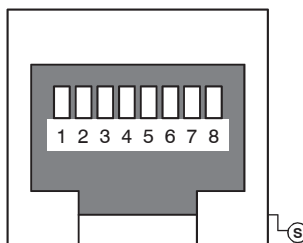

Figure 4: Interface circuit of CAN interface 1 ... 4

### 5.1.1 Connector Assignment RJ45

The four RJ45 connectors have the same pin-assignment, each for the corresponding CAN interface.

**Pin Position:**



**Pin Assignment:**

Pin	Signal
1	CANx_H
2	CANx_L
3	CANx_GND
4	-
5	-
6	-
7	CANx_GND ((GND) optional GND)
8	-

S	Shield
---	--------

**Signal Description:**

- CANx\_L, CANx\_H ... CAN signals of the CAN interface x (x... 1 - 4)
- CANx\_GND... reference potential of the local CAN physical layer of CAN interface x (x... 1 - 4)
- ... reserved for future applications, do not connect!
- Shield... case shield, connected with the shield potential of the MicroTCA system

### 5.1.2 CAN via AMC-CAN4-DSUB9-ADAPTER (Optional)

As an optional accessory the AMC-CAN4-DSUB9-ADAPTER (1.5 m, CAT6 SFTP) can be used as an adapter from RJ45 to DSUB9 connector.

Described connector: 9-pin DSUB connector, male

**Pin Position:**

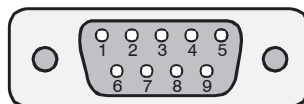

**Pin Assignment:**

Signal	Pin		Signal
-	1	6	CAN_GND ((GND), optional GND)
CAN_L	2		
CAN_GND	3	7	CAN_H
-	4	8	-
-	5	9	-
Shield	connected to DSUB9 case		

**Signal Description:**

CAN_L, CAN_H...	CAN signals
CAN_GND...	reference potential of local CAN physical layer
- ...	reserved for future applications, do not connect!
Shield...	cable shield, connected to DSUB9 case



## 6. Correctly Wiring Electrically Isolated CAN Networks



**Note:**

This chapter describes the correct wiring of electrically isolated CAN networks using DSUB9 connectors. It applies accordingly for the usage of RJ45 connectors

For the CAN wiring all applicable rules and regulations (EU, DIN), e.g. regarding electromagnetic compatibility, security distances, cable cross-section or material, have to be met.

### 6.1 Standards concerning CAN Wiring

The flexibility in CAN network design is one of the key strengths of the various extensions and additional standards like e.g. CANopen, ARINC825, DeviceNet and NMEA2000 that have been built on the original ISO 11898-2 CAN standard. In using this flexibility comes the responsibility of good network design and balancing these tradeoffs.

Many CAN organizations and standards have scaled the use of CAN for applications outside the original ISO 11898. They have made system level tradeoffs for data rate, cable length, and parasitic loading of the bus.

However for CAN network design margin must be given for signal loss across the complete system and cabling, parasitic loadings, network imbalances, ground offsets against earth potential and signal integrity. **Therefore the practical maximum number of nodes, bus length and stub length are typically much lower.**

esd has concentrated her recommendations concerning CAN wiring on the specifications of the ISO 11898-2. Thus this wiring hints forgoes to describe the special features of the derived standards CANopen, ARINC825, DeviceNet and NMEA2000.

The consistent compliance to ISO 11898-2 offers significant advantages:

- Durable operation due to well proven design specifications
- Minimizing potential failures due to sufficient margin to physical limits
- Trouble-free maintenance during future network modifications or during fault diagnostics due to lack of exceptions

Of course reliable networks can be designed according the specifications of CANopen, ARINC825, DeviceNet and NMEA2000, **however it must be observed that it is strictly not recommended to mix the wiring guidelines of the various specifications!**

## 6.2 Heavy Industrial Environment (*Double Twisted Pair Cable*)

### 6.2.1 General Rules

**Note:**  
 esd only grants the compliance with directive 2014/30/EU, if the CAN wiring is carried out with single shielded **double twisted** pair cables that match the requirements of ISO 11898-2.

The following **general rules** for the CAN wiring with single shielded *double* twisted pair cable should be followed:

1	A cable type with a wave impedance of about $120 \Omega \pm 10\%$ with an adequate conductor cross-section ( $\geq 0.22 \text{ mm}^2$ ) has to be used. The voltage drop over the wire has to be considered.
2	For heavy industrial environment use a four-wire CAN cable. Connect <ul style="list-style-type: none"> <li>• two twisted wires to the data signals (CAN_H, CAN_L) and</li> <li>• the other two twisted wires to the reference potential (CAN_GND) and</li> <li>• the cable shield to functional earth (FE) at least at one point.</li> </ul>
3	The reference potential CAN_GND has to be connected to the functional earth (FE) at exactly <b>one</b> point.
4	A CAN bus line must not branch (exception: short cable stubs) and has to be terminated with the characteristic impedance of the line (generally $120 \Omega \pm 10\%$ ) at both ends (between the signals CAN_L and CAN_H and <b>not</b> to CAN_GND).
5	Keep cable stubs as short as possible ( $l < 0.3 \text{ m}$ ).
6	Select a working combination of bit rate and cable length.
7	Keep away CAN cables from disturbing sources. If this can not be avoided, double shielded cables are recommended.

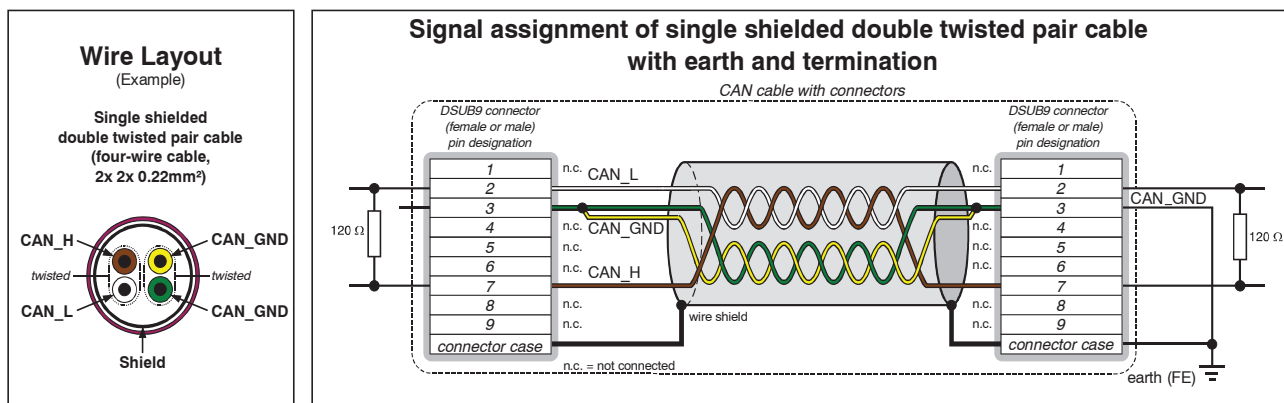

Figure 5: CAN wiring for heavy industrial environment

### 6.2.2 Device Cabling



**Attention:**

If single shielded *double* twisted pair cables are used, realize the T-connections by means of connectors that support connection of two CAN cables at one connector where the cable's shield is looped through e.g. DSUB9 connector from ERNI (ERBIC CAN BUS MAX, order no.:154039).

The usage of esd's T-connector type C.1311.03 is not recommended for single shielded *double* twisted pair cables because the shield potential of the conductive DSUB housing is not looped through this T-connector type.

If a mixed application of single twisted and double twisted cables is unavoidable, take care that the CAN\_GND line is not interrupted!

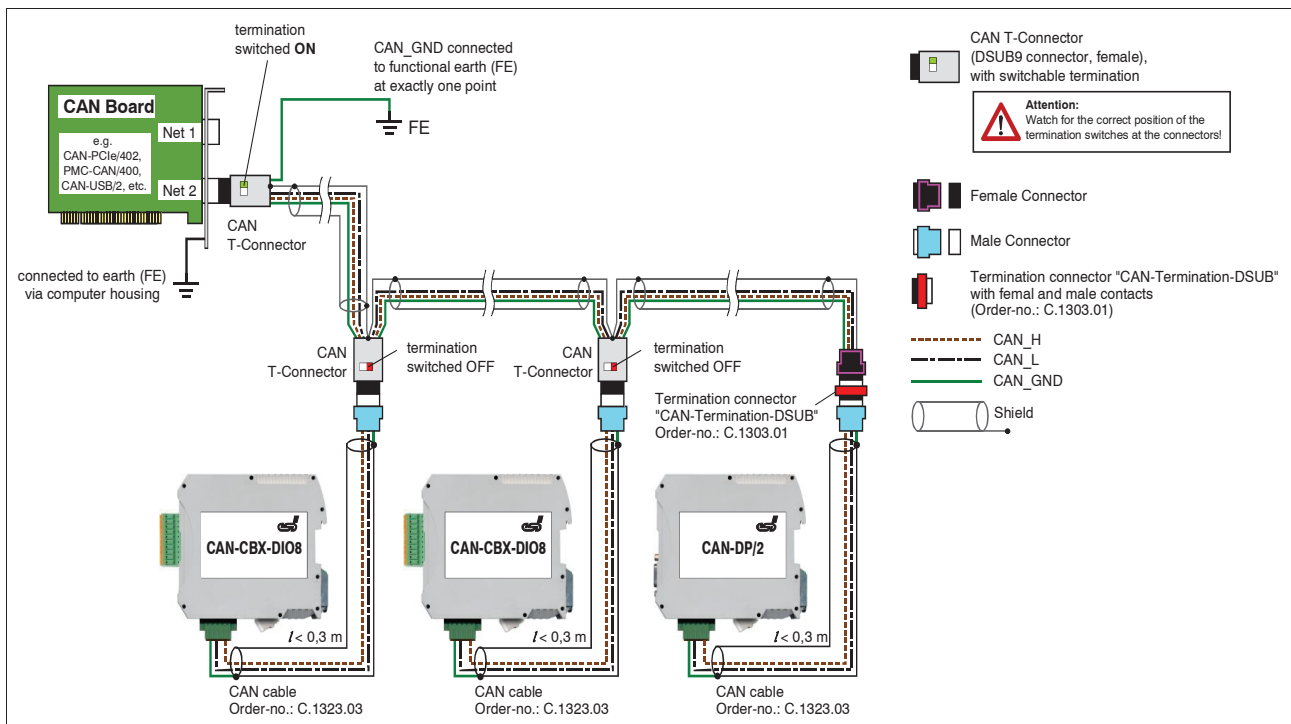

Figure 6: Example of proper wiring with single shielded double twisted pair cables

### 6.2.3 Termination

- A termination resistor has to be connected at both ends of the CAN bus. If an integrated CAN termination resistor which is equipped at the CAN interface at the end of the bus is connected, this one has to be used for termination instead of an external CAN termination plug.
- 9-pin DSUB-termination connectors with integrated termination resistor and male and female contacts (gender changer) are available from esd (order no. C.1303.01).
- 9-pin DSUB-connectors with integrated switchable termination resistor can be ordered e.g. from ERNI (ERBIC CAN BUS MAX, female contacts, order no.:154039).

## 6.3 Light Industrial Environment (*Single Twisted Pair Cable*)

### 6.3.1 General Rules

**Note:**  
 esd only grants the compliance with directive 2014/30/EU, if the CAN wiring is carried out with single shielded **double twisted** pair cables that match the requirements of ISO 11898-2. See previous chapter: 'Heavy Industrial Environment (Double Twisted Pair Cable)'.

The following **general rules** for CAN wiring with single shielded *single* twisted pair cable should be followed:

1	A cable type with a wave impedance of about $120\ \Omega \pm 10\%$ with an adequate conductor cross-section ( $\geq 0.22\ \text{mm}^2$ ) has to be used. The voltage drop over the wire has to be considered.
2	For light industrial environment use at least a two-wire CAN cable. Connect <ul style="list-style-type: none"> <li>• the two twisted wires to the data signals (CAN_H, CAN_L) and</li> <li>• the cable shield to the reference potential (CAN_GND).</li> </ul>
3	The reference potential CAN_GND has to be connected to the functional earth (FE) at exactly <b>one</b> point.
4	A CAN net must not branch (exception: short cable stubs) and has to be terminated with the characteristic impedance of the line (generally $120\ \Omega \pm 10\%$ ) at both ends (between the signals CAN_L and CAN_H and <b>not</b> at CAN_GND).
5	Keep cable stubs as short as possible ( $l < 0.3\ \text{m}$ ).
6	Select a working combination of bit rate and cable length.
7	Keep away cables from disturbing sources. If this cannot be avoided, double shielded wires are recommended.

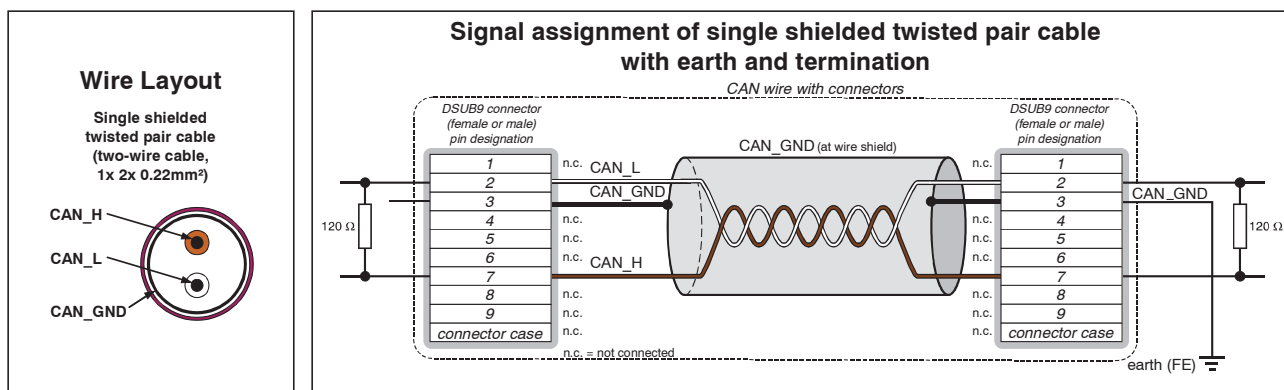

Figure 7: CAN wiring for light industrial environment

### 6.3.2 Cabling

- To connect CAN devices with just one CAN connector per net use a short stub (< 0.3 m) and a T-connector (available as accessory). If this devices are located at the end of the CAN network, the CAN terminator “CAN-Termination-DSUB9” can be used.

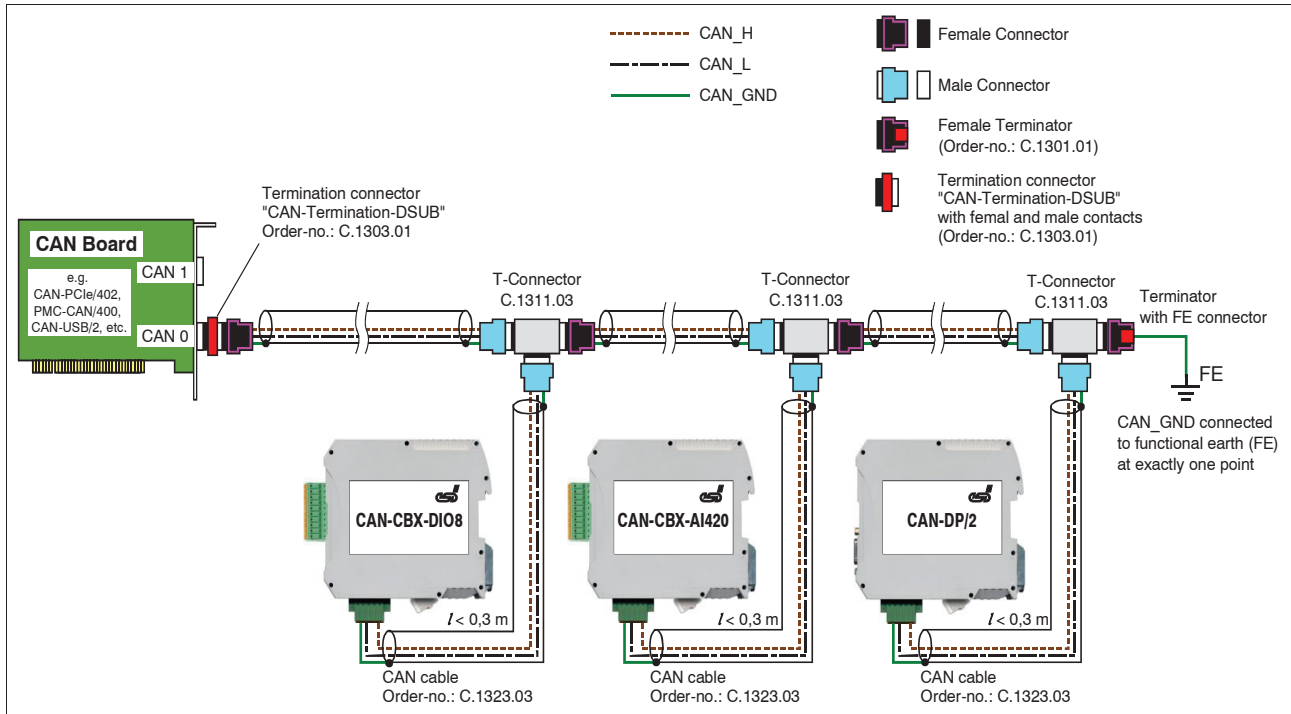

Figure 8: Example for proper wiring with single shielded single twisted pair wires

### 6.3.3 Termination

- A termination resistor has to be connected at both ends of the CAN bus. If an integrated CAN termination resistor which is equipped at the CAN interface at the end of the bus is connected, this one has to be used for termination instead of an external CAN termination plug.
- 9-pin DSUB-termination connectors with integrated termination resistor and male and female contacts (gender changer) are available from esd (order no. C.1303.01).
- DSUB termination connectors with male contacts (order no. C.1302.01) or female contacts (order no. C.1301.01) and additional functional earth contact are available, if CAN termination and grounding of CAN\_GND is required.

## 6.4 Electrical Grounding

- For CAN devices with electrical isolation the CAN\_GND must be connected between the CAN devices.
- CAN\_GND should be connected to the earth potential (FE) at **exactly one** point of the network.
- Each *CAN interface with electrical connection to earth potential* acts as a grounding point. For this reason it is recommended not to connect more than one *CAN device with electrical connection to earth potential*.
- Grounding can be made e.g. at a termination connector (e.g. order no. C.1302.01 or C.1301.01).

## 6.5 Bus Length

Bit rate [Kbit/s]	Typical values of reachable wire length with esd interface $I_{max}$ [m]	CiA recommendations (07/95) for reachable wire lengths $I_{min}$ [m]
1000	37	25
800	59	50
666.6	80	-
500	130	100
333.3	180	-
250	270	250
166	420	-
125	570	500
100	710	650
83,3	850	-
66.6	1000	-
50	1400	1000
33.3	2000	-
20	3600	2500
12.5	5400	-
10	7300	5000

**Table 6:** Recommended cable lengths at typical bit rates (with esd-CAN interfaces)

- Optical couplers are delaying the CAN signals. esd modules typically reach a wire length of 37 m at 1 Mbit/s within a proper terminated CAN network without impedance disturbances like e.g. caused by cable stubs > 0.3 m.

	<p><b>Note:</b> Please note the recommendations of ISO 11898 regarding to the configuration of the cable cross-section in dependance of the cable length.</p>
---	---

## 6.6 Examples for CAN Cables

esd recommends the following two-wire and four-wire cable types for CAN network design. These cable types are used by esd for ready-made CAN cables, too.

### 6.6.1 Cable for light industrial Environment Applications (Two-Wire)

Manufacturer	Cable Type
U.I. LAPP GmbH Schulze-Delitzsch-Straße 25 70565 Stuttgart Germany <a href="http://www.lappkabel.com">www.lappkabel.com</a>	e.g. UNITRONIC ®-BUS CAN UL/CSA (1x 2x 0.22) (UL/CSA approved) Part No.: 2170260
	UNITRONIC ®-BUS-FD P CAN UL/CSA (1x 2x 0.25) (UL/CSA approved) Part No.: 2170272
ConCab GmbH Äußerer Eichwald 74535 Mainhardt Germany <a href="http://www.concab.de">www.concab.de</a>	e. g. BUS-PVC-C (1x 2x 0.22 mm <sup>2</sup> ) Order No.: 93 022 016 (UL appr.)
	BUS-Schleppflex-PUR-C (1x 2x 0.25 mm <sup>2</sup> ) Order No.: 94 025 016 (UL appr.)

### 6.6.2 Cable for heavy industrial Environment Applications (Four-Wire)

Manufacturer	Cable Type
U.I. LAPP GmbH Schulze-Delitzsch-Straße 25 70565 Stuttgart Germany <a href="http://www.lappkabel.com">www.lappkabel.com</a>	e.g. UNITRONIC ®-BUS CAN UL/CSA (2x 2x 0.22) (UL/CSA approved) Part No.: 2170261
	UNITRONIC ®-BUS-FD P CAN UL/CSA (2x 2x 0.25) (UL/CSA approved) Part No.: 2170273
ConCab GmbH Äußerer Eichwald 74535 Mainhardt Germany <a href="http://www.concab.de">www.concab.de</a>	e. g. BUS-PVC-C (2x 2x 0.22 mm <sup>2</sup> ) Order No.: 93 022 026 (UL appr.)
	BUS-Schleppflex-PUR-C (2x 2x 0.25 mm <sup>2</sup> ) Order No.: 94 025 026 (UL appr.)



**Note:**

Ready-made CAN cables with standard or custom length can be ordered from **esd**.

## 7. CAN Troubleshooting Guide

The CAN Troubleshooting Guide is a guide to find and eliminate the most frequent hardware-error causes in the wiring of CAN networks.

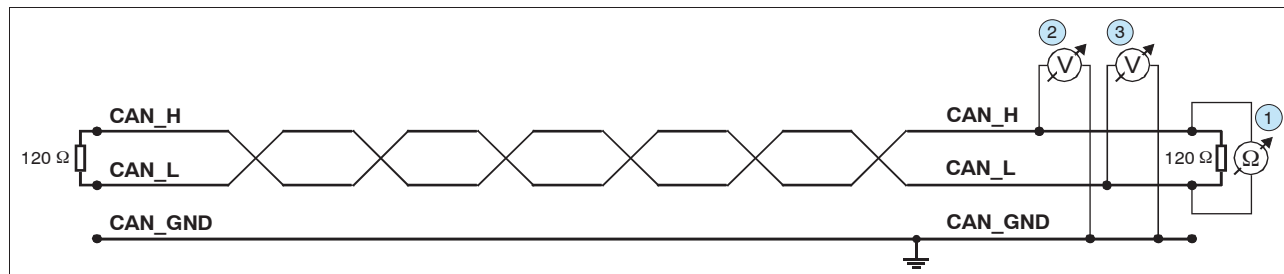

**Figure 9:** Simplified diagram of a CAN network

### 7.1 Termination

The termination is used to match impedance of a node to the impedance of the transmission line being used. When impedance is mismatched, the transmitted signal is not completely absorbed by the load and a portion is reflected back into the transmission line. If the source, transmission line and load impedance are equal these reflections are avoided. This test measures the series resistance of the CAN data pair conductors and the attached terminating resistors.

To test it ,please

1. Turn off all power supplies of the attached CAN nodes.
2. Measure the DC resistance between CAN\_H and CAN\_L at one end of the network ① (see figure above).

The measured value should be between 50 Ω and 70 Ω.

If the value is below 50 Ω, please make sure that:

- there is no **short circuit** between CAN\_H and CAN\_L wiring
- there are **not more than two** terminating resistors connected
- the nodes do not have faulty transceivers.

If the value is higher than 70 Ω, please make sure that:

- there are no open circuits in CAN\_H or CAN\_L wiring
- your bus system has two terminating resistors (one at each end) and that they are 120 Ω each.



## 7.2 Electrical Grounding

The CAN\_GND of the CAN network should be connected to the functional earth potential (FE) at only **one** point. This test will check if the CAN\_GND is grounded in several places.

To test it, please

1. Disconnect the CAN\_GND from the earth potential (FE).
2. Measure the DC resistance between CAN\_GND and earth potential (see figure on the right).
3. Reconnect CAN\_GND to earth potential.

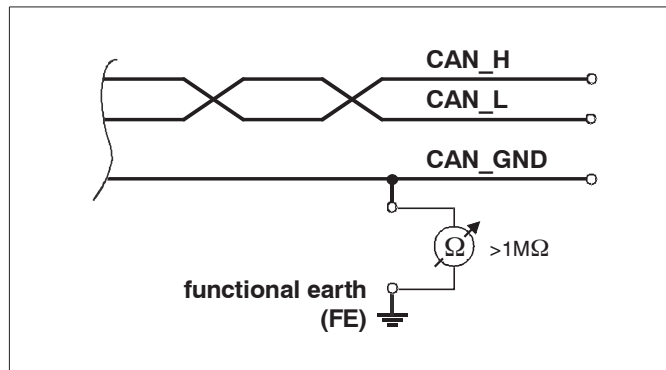

**Figure 10:** Simplified schematic diagram of ground test measurement

The measured resistance should be higher than 1 MΩ. If it is lower, please search for additional grounding of the CAN\_GND wires.

## 7.3 Short Circuit in CAN Wiring

A CAN bus might possibly still be able to transmit data if there is a short circuit between CAN\_GND and CAN\_L, but generally the error rate will increase strongly. Make sure that there is no short circuit between CAN\_GND and CAN\_L!

## 7.4 CAN\_H/CAN\_L-Voltage

Each node contains a CAN transceiver that outputs differential signals. When the network communication is idle the CAN\_H and CAN\_L voltages are approximately 2.5 V measured to CAN\_GND. Faulty transceivers can cause the idle voltages to vary and disrupt network communication.

To test for faulty transceivers, please

1. Turn on all supplies.
2. Stop all network communication.
3. Measure the DC voltage between CAN\_H and CAN\_GND ②  
(see figure at previous page).
4. Measure the DC voltage between CAN\_L and CAN\_GND ③  
(see figure at previous page).

Normally the voltage should be between 2.0 V and 3.0 V.

If it is lower than 2.0 V or higher than 3.0 V, it is possible that one or more nodes have faulty transceivers. For a voltage lower than 2.0 V please check CAN\_H and CAN\_L conductors for continuity.

To find the node with a faulty transceiver within a network please test the CAN transceiver resistance (see below) of the nodes.

## 7.5 CAN Transceiver Resistance Test

CAN transceivers have circuits that control CAN\_H and CAN\_L. Experience has shown that electrical damage of the circuits may increase the leakage current in these circuits.

To measure the current leakage through the CAN circuits, please use a resistance measuring device and:

1. Switch **off** the node and **disconnect** it from the network (4) (see figure below).
2. Measure the DC resistance between CAN\_H and CAN\_GND (5) (see figure below).
3. Measure the DC resistance between CAN\_L and CAN\_GND (6) (see figure below).

The measured resistance has to be about 500 k $\Omega$  for each signal. If it is much lower, the CAN transceiver it is probably faulty.

Another indication for a faulty transceiver is a very high deviation between the two measured input resistances (>> 200 %).

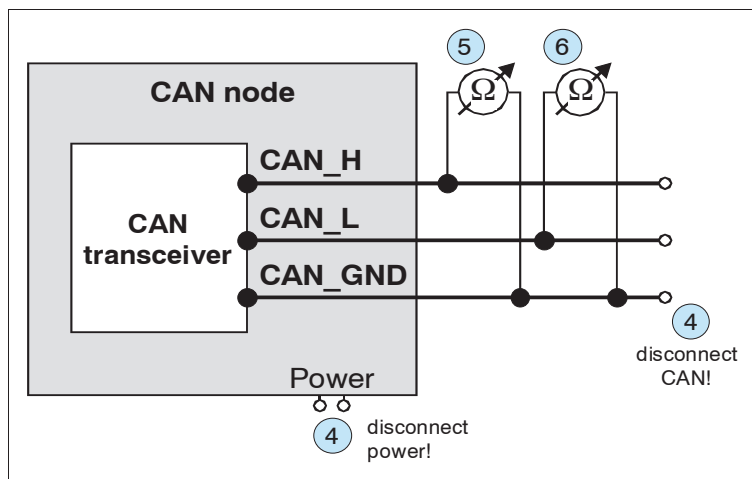

Figure 11: Measuring the internal resistance of CAN transceivers

## 7.6 Support by esd

If you have executed the fault diagnostic steps of this troubleshooting guide and you even can not find a solution for your problem our support department will be able to assist.

Please contact our support via email at [support@esd.eu](mailto:support@esd.eu) or by phone **+40-511-37298-130**.

## 8. Declaration of Conformity

### EU-KONFORMITÄTSERKLÄRUNG EU DECLARATION OF CONFORMITY



Adresse **esd electronic system design gmbh**  
Address **Vahrenwalder Str. 207**  
**30165 Hannover**  
**Germany**

esd erklärt, dass das Produkt  
*esd declares, that the product*

**AMC-CAN4**

Typ, Modell, Artikel-Nr.  
*Type, Model, Article No.*

**U.1002.01**

die Anforderungen der Normen  
*fulfills the requirements of the standards*

**EN 61000-6-2:2005,**  
**EN 61000-6-4:2007+A1:2011**

gemäß folgendem Prüfbericht erfüllt.  
*according to test certificate.*

**H-K00-0466-12**

Das Produkt entspricht damit der EU-Richtlinie „EMV“  
*Therefore the product conforms to the EU Directive 'EMC'*

**2014/30/EU**

Das Produkt entspricht der EU-Richtlinie „RoHS“  
*The product conforms to the EU Directive 'RoHS'*

**2011/65/EU**

Diese Erklärung verliert ihre Gültigkeit, wenn das Produkt nicht den Herstellerunterlagen entsprechend eingesetzt und betrieben wird, oder das Produkt abweichend modifiziert wird.  
*This declaration loses its validity if the product is not used or run according to the manufacturer's documentation or if non-compliant modifications are made.*

Name / Name T. Ramm  
Funktion / Title CE-Koordinator / CE Coordinator  
Datum / Date Hannover, 2015-02-12

Rechtsgültige Unterschrift / authorized signature

## 9. Order Information

Type	Properties	Order No.
AMC-CAN4	4x CAN interface, according to ISO 11898-2	U.1002.01
<i>The CAN-DRV-CD, a CD-ROM with CAN layer 2 software drivers* for Windows and Linux, demo programs and tools as well as documentation and manuals are included in delivery of AMC-CAN4.</i>		
<b>Accessories</b>		
AMC-CAN4-DSUB9-ADAPTER	Adapter cable, RJ45 male connector to 9-pin DSUB male connector, length 1.5 m	U.1002.10

\* For detailed information about the driver availability of your special operating system please contact our sales team.

**Table 7:** Order information

### PDF Manuals

For availability of English manuals see table below.

Please download the manuals as PDF documents from our esd website [www.esd.eu](http://www.esd.eu) for free.

Manuals		Order No.
AMC-CAN4-ME	Manual in English	U.1002.21
NTCAN-API-ME	NTCAN-API: Application Developers Manual NTCAN-API: Driver Installation Guide	C.2001.21
CANopen Manager/Slave Manual	CANopen API Manual	C.2002.21
J1939 Stack	Software Manual, J1939 Stack and SDK for esd CAN Hardware	C.1130.21

**Table 8:** Available manuals

### Printed Manuals

If you need a printout of the manual additionally, please contact our sales team: [sales@esd.eu](mailto:sales@esd.eu) for a quotation. Printed manuals may be ordered for a fee.