

TAMC261 PMC-Carrier for MTCA.4 Rear-I/O

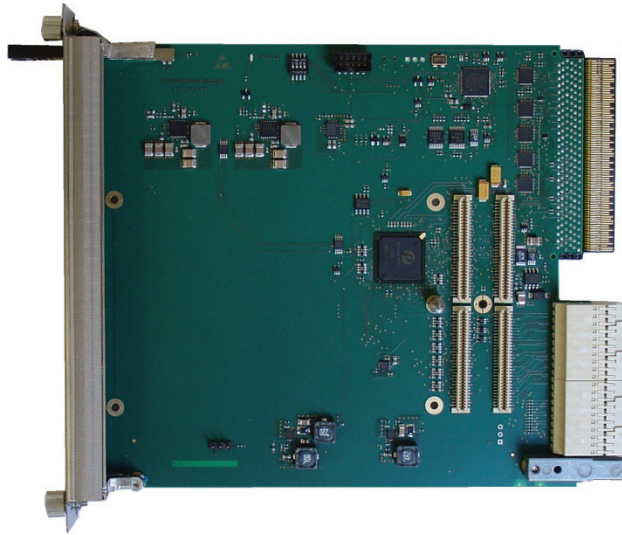

Application Information

The TAMC261 is a standard Mid-Size/Full-Size AMC.1 (PCI-Express) and MTCA.4 compliant PMC carrier module that provides one slot for a single-width PMC, used to build modular, flexible and cost effective I/O solutions for applications in process control, medical systems, telecommunication and traffic control.

A PI7C9X130 PCIe-to-PCI bridge provides the connection between primary PCIe link and the secondary PMC slot. The bridge controls all PCI accesses and the frequency for the PMC access. PCI is supported up to 64-bit @66MHz and PCI-X is supported up to 64-bit @133MHz.

The TAMC261 supports front panel I/O, alternatively the MTCA.4 interface provides access to the PMC P14 back I/O lines. According to MTCA.4, the TAMC261 provides

two 30-pair ADF connectors at the Zone 3 interface (Rear I/O) that provide access to all P14 back I/O lines via a compatible μ RTM.

The TAMC261-2x additionally provide M-LVDS transceivers connected to AMC port 12-15, port 17-20 and the TCLKA-D. All control and data lines of the M-LVDS transceivers are routed to the zone 3 interface, enabling a mounted PMC to access the AMC port signals via the μ RTM.

The TAMC261 is a versatile solution to upgrade well known legacy I/O solutions to a high performance form factor.

According to AMC.0, the TAMC261 provides an IPMI compliant Module Management Controller (MMC) with temperature monitoring and hot-swap support.

Technical Information

- Form Factor: PICMG MTCA.4 Module
 - Board size: 180.6 mm x 146.5 mm
 - Double-width / Mid-Size or Full-Size
- x4 PCIe Link (AMC.1 Type 1 compliant)
- IPMI V1.5 support
- Front Panel LEDs:
 - Blue Hot-Swap LED
 - Red Power Good LED (LED1)
 - Green PMC-Present LED (LED2)
- One PMC site conforming to IEEE 1386.1 (PMC) and ANSI/VITA 39-2003 (PCI-X for PMCs)
- Rear-I/O access to all 64 P14 back I/O lines via a compatible RTM (for example TAMC020-TM)
- 64-bit PCI @66MHz
- 64-bit PCI-X @133MHz
- 5V tolerant PCI I/O signaling
- TAMC261-2x: M-LVDS transceivers on AMC port 12-15, port 17-20 and TCLKA, TCLKB, TCLKC and TCLKD connected to zone 3 interface
- Operating temperature -40°C to +85°C
- MTBF (MIL-HDBK217F/FN2 G_B 20°C)
 - TAMC261-1x: 281.000 h
 - TAMC261-2x: 254.000 h

right to change technical specification without further notice.
eir respective owners.

Issue 1.0.1
2017-09-20

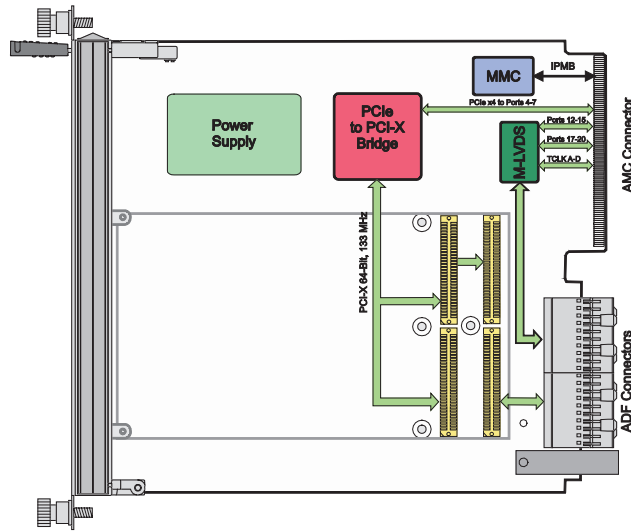

Order Information

RoHS Compliant

TAMC261-10R Mid-Size PMC-Carrier for MTCA.4 Rear-I/O.

TAMC261-11R Full-Size PMC-Carrier for MTCA.4 Rear-I/O.

TAMC261-20R Mid-Size PMC-Carrier for MTCA.4 Rear-I/O, with additional M-LVDS transceivers

TAMC261-21R Full-Size PMC-Carrier for MTCA.4 Rear-I/O, with additional M-LVDS transceivers

For the availability of non-RoHS compliant (lead solder) products please contact TEWS.

Documentation

TAMC261-DOC User Manual

Related Products

TAMC020-TM MTCA.4 compatible μ RTM for Rear-I/O access to the PMC back I/O lines