

*The Embedded I/O Company*



---

# TXMC888

## Two Channel SFP+ 10Gb Ethernet Adapter

Version 1.0

### User Manual

Issue 1.0.2

December 2017



Ehlbeek 15a  
30938 Burgwedel  
fon 05139-9980-0  
fax 05139-9980-49

[www.powerbridge.de](http://www.powerbridge.de)  
[info@powerbridge.de](mailto:info@powerbridge.de)

---

TEWS TECHNOLOGIES GmbH  
Am Bahnhof 7 25469 Halstenbek, Germany  
+49 (0) 4101 4058 0 Fax: +49 (0) 4101 4058 19  
mail: [info@tews.com](mailto:info@tews.com) [www.tews.com](http://www.tews.com)

## TXMC888-10R

Two channel 10 Gigabit Ethernet interface SFP+  
front panel I/O  
(RoHS compliant)

This document contains information, which is proprietary to TEWS TECHNOLOGIES GmbH. Any reproduction without written permission is forbidden.

TEWS TECHNOLOGIES GmbH has made any effort to ensure that this manual is accurate and complete. However TEWS TECHNOLOGIES GmbH reserves the right to change the product described in this document at any time without notice.

TEWS TECHNOLOGIES GmbH is not liable for any damage arising out of the application or use of the device described herein.

### Style Conventions

Hexadecimal characters are specified with prefix 0x, i.e. 0x029E (that means hexadecimal value 029E).

For signals on hardware products, an 'Active Low' is represented by the signal name with # following, i.e. IP\_RESET#.

Access terms are described as:

W	Write Only
R	Read Only
R/W	Read/Write
R/C	Read/Clear
R/S	Read/Set

©2015-2017 by TEWS TECHNOLOGIES GmbH

All trademarks mentioned are property of their respective owners.

---

<b>Issue</b>	<b>Description</b>	<b>Date</b>
1.0.0	Initial issue	November 2015
1.0.1	Product description updated	March 2016
1.0.2	Storage Temperature Range corrected	December 2017

---

## Table of Contents

<b>1</b>	<b>PRODUCT DESCRIPTION .....</b>	<b>6</b>
<b>2</b>	<b>TECHNICAL SPECIFICATION .....</b>	<b>8</b>
<b>3</b>	<b>10 GIGABIT ETHERNET CONTROLLER.....</b>	<b>9</b>
3.1	PCI Bus Topology .....	9
3.2	Intel 82599ES Function PCI Header .....	9
<b>4</b>	<b>LEDS .....</b>	<b>10</b>
<b>5</b>	<b>PIN ASSIGNMENT – I/O CONNECTOR .....</b>	<b>11</b>
5.1	XMC Connector P15.....	11
5.2	SFP+ Connector .....	12

---

## List of Figures

FIGURE 1-1 : BLOCK DIAGRAM.....	7
FIGURE 4-1 : TXMC888 FRONT PANEL .....	10

## List of Tables

TABLE 2-1 : TECHNICAL SPECIFICATION.....	8
TABLE 3-1 : INTEL 82559ES PCI HEADER.....	9
TABLE 4-1 : LED BEHAVIOR .....	10
TABLE 5-1 : XMC CONNECTOR P15 .....	11
TABLE 5-2 : SFP+ CONNECTOR.....	12

---

# 1 Product Description

The TXMC888 is a Switched Mezzanine Card (XMC) compatible module providing a two channel 10 Gigabit Ethernet Enhanced Small Form Factor Pluggable (SFP+) interface.

The XMC-Connector P15 provides access to the Intel™ 82599ES dual port 10GbE controller via an x8 PCIe link.

The TXMC888's SFP+ Cages accept various SFP and SFP+ transceiver modules. These two SFP+ hosts are connected to the Ethernet Controller's SFI Interfaces.

The following transceiver modules have been successfully tested with the TXMC888:

- Intel XDACBL1M  
(SFP+ Direct Attach Twinaxial Cable)
- Finisar FCBG110SD1C01  
(SFP+ SFPwire Active Optical Cable)
- Intel E10GSFPSR  
(SFP+ 10GBASE-SR or 1000BASE-SX)
- Finisar FTLX8571D3BCV  
(SFP+ 10GBASE-SR or 1000BASE-SX)
- Intel E10GSFPLR  
(SFP+ 10GBASE-LR or 1000BASE-LX)
- Finisar FTLX1471D3BCV  
(SFP+ 10GBASE-LR or 1000BASE-LX)
- Finisar FCLF8522P2BTL  
(SFP 1000BASE-T)

All compatible transceivers modules and replacements of the tested modules will also work properly with the TXMC888.

The controller is equipped with a 1 Mbit serial flash memory for Boot ROM and a 128 Kbit EEPROM storing configuration data. LEDs in the front panel indicate the different network activities.

For preconfigured variants of the hardware module containing transceiver modules, please contact TEWS.

The TXMC888-10R provides two 10GbE Interfaces via front panel SFP+ connectors.

## **Software support:**

- Software support for Intel™ 82599ES at [www.intel.com](http://www.intel.com)
- For operating systems not supported by Intel™, please contact TEWS.

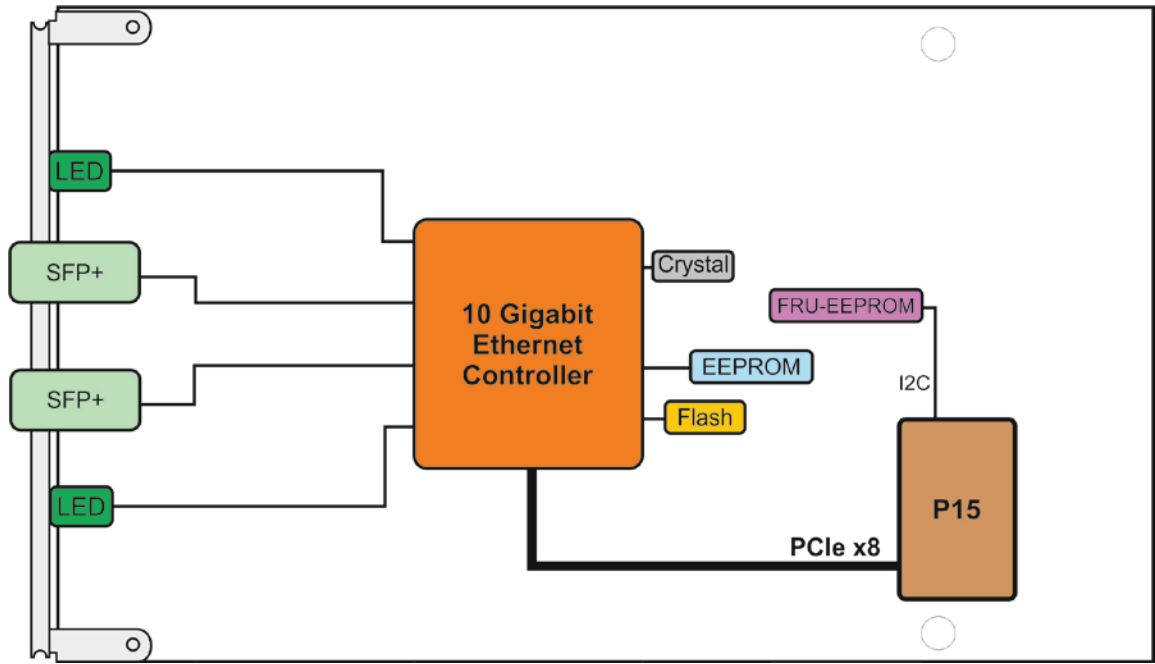

Figure 1-1 : Block Diagram

## 2 Technical Specification

<b>XMC Interface</b>	
<b>Mechanical Interface</b>	Switched Mezzanine Card (XMC) Interface conforming to ANSI/VITA 42.0-2008 (Auxiliary Standard) Standard single-width (149 mm x 74 mm)
<b>Electrical Interface</b>	PCI Express (Base Specification 2.0) up to x8 compliant interface conforming to ANSI/VITA 42.3-2006 (XMC PCI Express Protocol Layer Standard)
<b>On Board Devices</b>	
<b>10 Gigabit Ethernet Controller</b>	82599ES (Intel)
<b>IPMI resource FRU Data EEPROM</b>	M24C02 (STMicroelectronics)
<b>Ethernet Interface</b>	
<b>Number of Interfaces</b>	2
<b>Link</b>	10GBase-CU (SFP+ Direct Attach, twinax) SFPwire SFP+ Active Optical Cable 10GBase-SR/SW / 1000Base-SX 10GBase-LR/LW / 1000Base-LX 1000Base-T
<b>I/O Connector</b>	SFP+ (Molex 74754-0103 and 74441-0001 or compatible)
<b>Physical Data</b>	
<b>Power Requirements</b>	350mA typical @ VPWR = +12V DC (no link) app. -10mA per 1Gbit/s Link app. additional 50mA per 10Gbit/s Link  800mA typical @ VPWR = +5V DC (no link) app. -30mA per 1Gbit/s Link app. additional 100mA per 10Gbit/s Link  1mA typical @ +3.3Vaux DC
<b>Temperature Range</b>	Operating    0°C to +70°C Storage       -40°C to +85°C
<b>MTBF</b>	555000 h MTBF values shown are based on calculation according to MIL-HDBK-217F and MIL-HDBK-217F Notice 2; Environment: G <sub>B</sub> 20°C. The MTBF calculation is based on component FIT rates provided by the component suppliers. If FIT rates are not available, MIL-HDBK-217F and MIL-HDBK-217F Notice 2 formulas are used for FIT rate calculation.
<b>Humidity</b>	5 – 95 % non-condensing
<b>Weight</b>	105 g

Table 2-1 : Technical Specification



### 3 10 Gigabit Ethernet Controller

#### 3.1 PCI Bus Topology

The Intel 82599ES 10 Gigabit Ethernet Controller is represented by a multifunctional device on the PCI bus. The two different Ethernet Channels can be identified by the corresponding function of the device.

##### Multifunctional device (Intel Corporation)

Bus : Device : **Function 0x00**

Ethernet Controller	
Vendor ID	0x8086 (Intel Corporation)
Device ID	0x10FB (82599ES 10-Gigabit SFI/SFP+ Network Connection)

Bus : Device : **Function 0x01**

Ethernet Controller	
Vendor ID	0x8086 (Intel Corporation)
Device ID	0x10FB (82599ES 10-Gigabit SFI/SFP+ Network Connection)

#### 3.2 Intel 82599ES Function PCI Header

PCI CFG Register Address	Write '0' to all unused (Reserved) bits							PCI writeable	Initial Values (Hex Values)
	31	24	23	16	15	8	7		
0x00	Device ID			Vendor ID				N	10FB 8086
0x04	Status Register			Command Register				Y	0010 0406
0x08	Class Code		Subclass		Programming Interface		Revision ID	Y[7:0]	02 00 00 01
0x0C	BIST		Header Type		Latency Timer		Cache Line Size	Y[7:0]	00 80 00 10
0x10	Base Address Register 0							Y	FFFE0004
0x14	Base Address Register 1							Y	FFFFFFFF
0x18	Base Address Register 2							Y	FFFFFFE1
0x1C	Base Address Register 3							Y	00000000
0x20	Base Address Register 4							Y	FFFFC004
0x24	Base Address Register 5							Y	FFFFFFFF
0x28	CardBus CIS							N	00000000
0x2C	Subsystem Device ID			Subsystem Vendor ID				N	FFFF FFFF
0x30	Expansion ROM							Y	00000000
0x34	Reserved					Capabilities Pointer		N	000000 40
0x38	Reserved							N	00000000
0x3C	Max_Lat		Min_Gnt		Interrupt Pin		Interrupt Line	Y[7:0]	00 00 <b>01/02</b> 00
0x40	PMC			Next_Item_Ptr		Cap_ID		N	4823 50 01
0x44	Unknown		Data Register		PMCSR			Y	00 00 1E00

Table 3-1 : Intel 82559ES PCI Header

## 4 LEDs

The TXMC888 provides four LEDs in the front panel for each of the two channels indicating the corresponding network behavior.

LED	Colour	Description
10G	Yellow	Asserted when a 10 Gbit/s link is established and maintained
1G	Blue	Asserted when a 1 Gbit/s link is established and maintained
ACT	Green	Active when link is established and packets are being transmitted or received
100M	Orange	Asserted when a 100 Mbit/s link is established and maintained

Table 4-1 : LED behavior

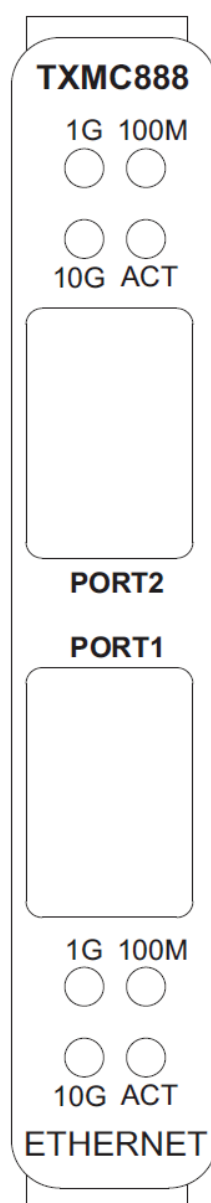

Figure 4-1 : TXMC888 Front Panel

## 5 Pin Assignment – I/O Connector

### 5.1 XMC Connector P15

	A	B	C	D	E	F
1	PET0p0	PET0n0	3.3V	PET0p1	PET0n1	VPWR
2	GND	GND	$\overline{TRST}$	GND	GND	$\overline{PERST}$
3	PET0p2	PET0n2	3.3V	PET0p3	PET0n3	VPWR
4	GND	GND	TCK	GND	GND	$\overline{MRSTO}$
5	PET0p4	PET0n4	3.3V	PET0p5	PET0n5	VPWR
6	GND	GND	TMS	GND	GND	+12V
7	PET0p6	PET0n6	3.3V	PET0p7	PET0n7	VPWR
8	GND	GND	TDI	GND	GND	-12V
9	Reserved	Reserved	Reserved	Reserved	Reserved	VPWR
10	GND	GND	TDO	GND	GND	GA0
11	PER0p0	PER0n0	$\overline{MBIST}$	PER0p1	PER0n1	VPWR
12	GND	GND	GA1	GND	GND	$\overline{MPRESENT}$
13	PER0p2	PER0n2	3.3V AUX	PER0p3	PER0n3	VPWR
14	GND	GND	GA2	GND	GND	MSDA
15	PER0p4	PER0n4	Reserved	PER0p5	PER0n5	VPWR
16	GND	GND	MVMRO	GND	GND	MSCL
17	PER0p6	PER0n6	Reserved	PER0p7	PER0n7	Reserved
18	GND	GND	Reserved	GND	GND	Reserved
19	REFCLK+0	REFCLK-0	Reserved	$\overline{WAKE}$	$\overline{ROOT0}$	Reserved

Table 5-1 : XMC Connector P15

---

## 5.2 SFP+ Connector

Pin	Signal
1	VeeT
2	Tx_Fault
3	Tx_Disable
4	SDA
5	SCL
6	Mod-ABS
7	RS0
8	Rx_LOS
9	RS1
10	VeeR
11	VeeR
12	RD-
13	RD+
14	VeeR
15	VccR
16	VccT
17	VeeT
18	TD+
19	TD-
20	VeeT

Table 5-2 : SFP+ Connector