

L2 & L3 Gigabit Ethernet Switch

cPCI_3U

4050a_3U

- 10 * 10/100/1000 Ethernet ports with a full-wire speed switching capacity of up to 37Mpps.

Layer2 Switching capabilities :

- 16K entries forwarding data-base
- Automatic or controlled learning and aging routing table
- Full-line rate switching engine
- Port and MAC access control
- Flow control and backpressure
- 9 KB Jumbo Frame
- IPV4 IGMP IPV6 MLD snooping
- MAC address transplanting for Rapid Reconfiguration 802.1w

Link aggregation static or LACP

Bandwidth management :

- Multicast rate limiting
- Egress rate shaping with rate ranging port from 64K to 1Gbs
- Minimal bandwidth guarantee per traffic Class

VLANs services :

- 4K actives VLANs
- 4K Bridge multicast groups
- Flexible VLAN assignment 802.1Q port -based, protocol based 802.1v, service Vlans 802.1ad, Policy-based Vlans

Quality of Service engine :

- 8 priority queues per port
- Traffic Class assignment according to 802-1p tag, MAC address, Port, DiffServ CP or Po-licy engine

L3 IP V4 & V6 routing :

- 1K UC ARP entries
- RIPV2, OSPF V2 Routing
- proxy-ARP
- DHCP relay

Security features :

- 802.1X Port authentication
- Multicast/Broadcast limiting
- STP/RSTP protocol
- Virtual cable tester On-Line

Flexible management tools :

- Web or CLI management
- Standard & private MIBs
- Enhanced Port mirroring
- Easy software updating



Description

The ComEth4050a 3U is built on the latest generation of Gigabit switch engine and PHY transceiver. It combines a layer 2+ switch and a full layer 3 router in a single equipment with an optimized power consumption.

ComEth4050a 3U supports full-wire speed L2 bridging and L3 routing with L2-L4 advanced traffic classification, filtering and prioritization. For instance, it can provide strict priority traffic needed for delay-sensitive or critical applications.

ComEth4050a ports are compatible with cPCI 3U 32-bit system. Ten GigaEthernet are routed on J2 rear I/O connector. Two Giga Ethernet channels are available on the front or on the rear panel through a RTM. The optional front fiber ports use LC connectors. The Gigabit transceivers select automatically the media with activity.

Auto-crossover, auto-polarity, auto-negotiation and automatic MAC address management make ComEth4050a 3U a true Plug&Play switch.

The Marvell Virtual Cable tester allows a remote identification of potential cable malfunctions as excessive pair skew, cable opens, impedance mismatch...

This switch is fully upward compatible with ComEth4000a, 40x0 range.

Management Capabilities

The ComEth4050a 3U can be monitored from a browser, a CLI or SNMP. The whole system can be easily managed and handled. A comprehensive Built-in test makes easier the maintenance of this switch. Many additional functions are provided on this full-managed version :

- Configuration of all the PHY and switch parameters: ports monitoring, static MAC address, QoS policy, Multicast and VLAN control, STP/RSTP protocols, MAC security
- Monitoring of all statistical counters and an extensive list of RMON counters

The Switchware software provides layer 3 functions, allowing local IP forwarding (IPv4/IPv6), static and dynamic protocols (RIP, OSPF) routing, proxy-ARP and DHCP-relay. These L3 functions are managed through a CLI interface. The IP routing and the L3 protocols are carried out by the processor and the forwarding by a full-speed L3 engine router.

ComEth4050a can be used as an open switching platform to implement specific functionalities.

Flexible configurations

Its 3U form factor allows the ComEth4050a to be integrated in cPCI 3U or stand-alone applications. ComEth4050a is available from standard to Conduction-Cooled grade.

COMETH 4050a_3U

L2 & L3 Gigabit Ethernet Switch— cPCI 3U

Main features

Physical layer

10 auto-sensing 10/100/1000Mbps ports.
Auto-Negotiation with Downshift , automatic polarity correction

1000SX transceivers with :

LC-duplex connectors with 850nm source
maximum link lengths :
275m for 62.5/125µm MMfiber or 550m for 50/125µm fiber

1000LX transceivers with :

LC-duplex connectors with 1300nm source
maximum link lengths :
550m for 62.5/125µm MMfiber or
10 Km for 8/125µm SM fiber

Consult us for other Fiber transceiver : WDM or 1500nm

Layer 2 switching

802.1D/Q Compliant with a full-line rate Ethernet switching engine
16000 MAC address database
automatic or controlled aging and learning mechanism,
Tag extraction and insertion
(802.1p), Jumbo frames up to 9KBytes.
Back pressure for half-duplex, IEEE802.3x for full-duplex.
Discard broadcasts above critical threshold.
Link aggregation with static or dynamic LACP (7 trunks of 8 channels)
Enhanced port mirroring.

VLAN

802.1Q compliant, Layer 2 partitioning of up to 4000 active VLANs.
VLAN is flexibly programmed to any value from 1 to 4094 Protocol-based
VLAN (802.1v) or Port-based VLAN (802.1v).

Security

Port and MAC access control compliant with 802.1X authentication.

L2/3 QoS

Eight queues per port.
Minimal and maximal bandwidth affectation per traffic class using weighted
round robin and strict priority scheduling.

L3 services

IGMP V2 (+ IGMP & MLD snooping)
RIP V2, OSPF V2
UDP relay
STP/RSTP provides redundant link support. Rapid STP capability for mini-
mizing STP convergence.

Front panel LEDs

Power supply and Switch status
Switched ports : activity & link

VME

3.3VDC Power Supply only

Power supply

Ptyp=32W

Switch Management

Onboard firmware is implemented with comprehensive Built-In Test (loop
back mode used during the diagnostic), maintenance functions and network
(BootP) updating functions.

Management software provides a wide range of configuration L2/3 functions
on any port : transmission speed/mode, VLAN, STP parameters, mirroring,
QoS, etc.

Supervision get lots of information in real time on the switch.

MIB, RMON counters and private informations are reachable from SNMP
agent, web-browser and CLI for L3 functions. This Open Application, named
SWITCHWARE, is carried out by a PowerPC processor.

Standard Conformance

Emissions

EN55022 Class A

Immunity

CEI 6000-4-2 (ESD), 6000-4-3 (Electric field), 6000-4-4 (Burst), 6000-4-5
(Surge).

Security

EN60950MTBF

Environment

See ordering grade Information.

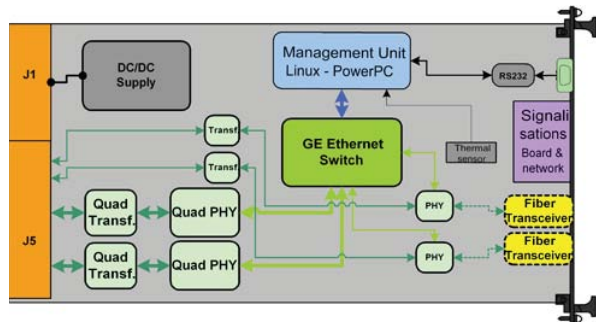

Rear Transition Module:

Ref. RTM05, RTM10

Environnement Specifications:

Please consult the ComEth 4050a_3U page at www.interfaceconcept.com.

Ordering Information:

Please contact our sales department : tel. +33 (0)2 98 573 030 - email : info@interfaceconcept.com

This document supersedes any earlier documentation relating to the products referred to herein. The information contained in this document is current at the date of publication. It may subsequently be updated or withdrawn without notice.

