

*The Embedded I/O Company*



---

# TPCE260

## PCI Express PMC Carrier

Version 1.0

### User Manual

Issue 1.0.1

August 2014



Ehlbeek 15a  
30938 Burgwedel  
fon 05139-9980-0  
fax 05139-9980-49

[www.powerbridge.de](http://www.powerbridge.de)  
[info@powerbridge.de](mailto:info@powerbridge.de)

---

**TEWS TECHNOLOGIES GmbH**

Am Bahnhof 7 25469 Halstenbek, Germany  
Phone: +49 (0) 4101 4058 0 Fax: +49 (0) 4101 4058 19  
e-mail: [info@tews.com](mailto:info@tews.com) [www.tews.com](http://www.tews.com)

## TPCE260-10R

PCI Express PMC Carrier, 5V PCI VI/O, +12V Power Supply from PCIe Connector

## TPCE260-11R

PCI Express PMC Carrier, 3.3V PCI VI/O, +12V Power Supply from PCIe Connector

## TPCE260-20R

PCI Express PMC Carrier, 5V PCI VI/O, +12V Power Supply via PCIe Graphics Power Connector, 2 x 5.25" to 6-pin adapter cable included

## TPCE260-21R

PCI Express PMC Carrier, 3.3V PCI VI/O, +12V Power Supply via PCIe Graphics Power Connector, 2 x 5.25" to 6-pin adapter cable included

This document contains information, which is proprietary to TEWS TECHNOLOGIES GmbH. Any reproduction without written permission is forbidden.

TEWS TECHNOLOGIES GmbH has made any effort to ensure that this manual is accurate and complete. However TEWS TECHNOLOGIES GmbH reserves the right to change the product described in this document at any time without notice.

TEWS TECHNOLOGIES GmbH is not liable for any damage arising out of the application or use of the device described herein.

### Style Conventions

Hexadecimal characters are specified with prefix 0x, i.e. 0x029E (that means hexadecimal value 029E).

For signals on hardware products, an 'Active Low' is represented by the signal name with # following, i.e. IP\_RESET#.

Access terms are described as:

W	Write Only
R	Read Only
R/W	Read/Write
R/C	Read/Clear
R/S	Read/Set

©2014 by TEWS TECHNOLOGIES GmbH

All trademarks mentioned are property of their respective owners.

---

<b>Issue</b>	<b>Description</b>	<b>Date</b>
1.0.0	Initial Issue	May 2011
1.0.1	General Revision	August 2014

# Table of Contents

<b>1</b>	<b>PRODUCT DESCRIPTION .....</b>	<b>6</b>
<b>2</b>	<b>TECHNICAL SPECIFICATION .....</b>	<b>7</b>
<b>3</b>	<b>HANDLING AND OPERATING INSTRUCTIONS .....</b>	<b>8</b>
3.1	ESD Protection .....	8
3.2	PCI Bus Signaling Voltage and Keying .....	8
3.3	Power Limits for PMC Modules .....	8
3.4	Installation of PMC Modules .....	8
<b>4</b>	<b>PCIE-TO-PCI BRIDGE .....</b>	<b>9</b>
4.1	PCI Configuration Registers .....	9
4.1.1	PCIe-to-PCI Bridge Configuration Space Header .....	9
4.2	PCI Bus Device Number Mapping .....	10
4.3	PCI Clock Frequency .....	10
<b>5</b>	<b>PMC INTERFACE .....</b>	<b>11</b>
5.1	PMC BUSMODE[4:1] Signals .....	11
5.2	PCI Signaling Voltage .....	11
5.2.1	V_I/O Configuration .....	11
5.2.2	Voltage Keying Configuration .....	12
5.3	Power Limits for PMC Modules .....	13
5.4	Installation of a PMC Module .....	13
<b>6</b>	<b>PIN ASSIGNMENTS .....</b>	<b>14</b>
6.1	PMC J11 / P11 .....	14
6.2	PMC J12 / P12 .....	15
6.3	PMC J14 / P14 .....	16
6.4	X4 VG64 Rear-I/O Connector .....	17

## List of Figures

FIGURE 1-1 : BLOCK DIAGRAM.....	6
FIGURE 5-1 : PCI SIGNALING VOLTAGE CONFIGURATION RESISTORS.....	11
FIGURE 5-2 : PMC VOLTAGE KEYING .....	12

## List of Tables

TABLE 2-1 : TECHNICAL SPECIFICATION.....	7
TABLE 4-1 : PCIE-TO-PCI BRIDGE CONFIGURATION SPACE HEADER .....	9
TABLE 4-2 : PCI BUS DEVICE NUMBER MAPPING.....	10
TABLE 5-1 : TPCE260 PMC BUSMODE[4:1] SIGNALS .....	11
TABLE 5-2 : TPCE260 PCI SIGNALING VOLTAGE FACTORY DEFAULTS .....	11
TABLE 5-3 : PCI SIGNALING VOLTAGE CONFIGURATION RESISTORS.....	11
TABLE 5-4 : PCI SIGNAL VOLTAGE CONFIGURATION MATRIX.....	12
TABLE 5-5 : CURRENT LIMITS FOR THE PMC MODULES.....	13
TABLE 6-1 : PMC J11/P11 PIN ASSIGNMENT .....	14
TABLE 6-2 : PMC J12/P12 PIN ASSIGNMENT.....	15
TABLE 6-3 : PMC J14/P14 PIN ASSIGNMENT .....	16
TABLE 6-4 : X4 VG64 PIN ASSIGNMENT .....	17

# 1 Product Description

The TPCE260 is a standard height PCI Express Revision 1.1 compatible module that provides one slot for a single-width PMC module used to build modular, flexible and cost effective I/O solutions for all kinds of applications like process control, medical systems, telecommunication and traffic control. The TPCE260 is a versatile solution to upgrade well known PMC I/O solutions to the PCI Express signaling standard.

The bridging between the system host board and the PMC slot is handled by the transparent PCIe-to-PCI Bridge PI7C9X111SL from Pericom.

The PCI bus side of the bridge allows 32-bit PCI accesses with either 33 MHz or 66 MHz. Both 3.3V (TPCE260-x1R) and 5V (TPCE260-x0R) PCI I/O signaling voltages are supported.

The TPCE260 supports PMC front panel I/O and also PMC P14 Rear I/O through a VME P2 style connector (IEC 60603-2, Type C). The I/O mapping of P14 complies with VITA-35 (“PMC P4 to VME-P2, Rows A-C mapping”).

The PCIe edge card connector provides +12V and +3.3V. All TPCE260-xx variants use the +3.3V solely to power the PCIe-to-PCI Bridge. The TPCE260-1xR uses the +12V of the PCIe edge card connector to generate all four power supply voltages for the PMC slot (+3.3V, +5V, +12V and -12V). According to the PCIe specification, a PCIe x1 card is limited to 6W on the +12V which allows to operate most of the available 32-bit 33/66 MHz PMC modules on the TPCE260-1xR.

For PMC modules with increased power requirements, the TPCE260-2xR offer a PCIe Graphics Power Connector to supply the +12V for generating all the power supply voltages for the PMC slot providing a power of up to 25W.

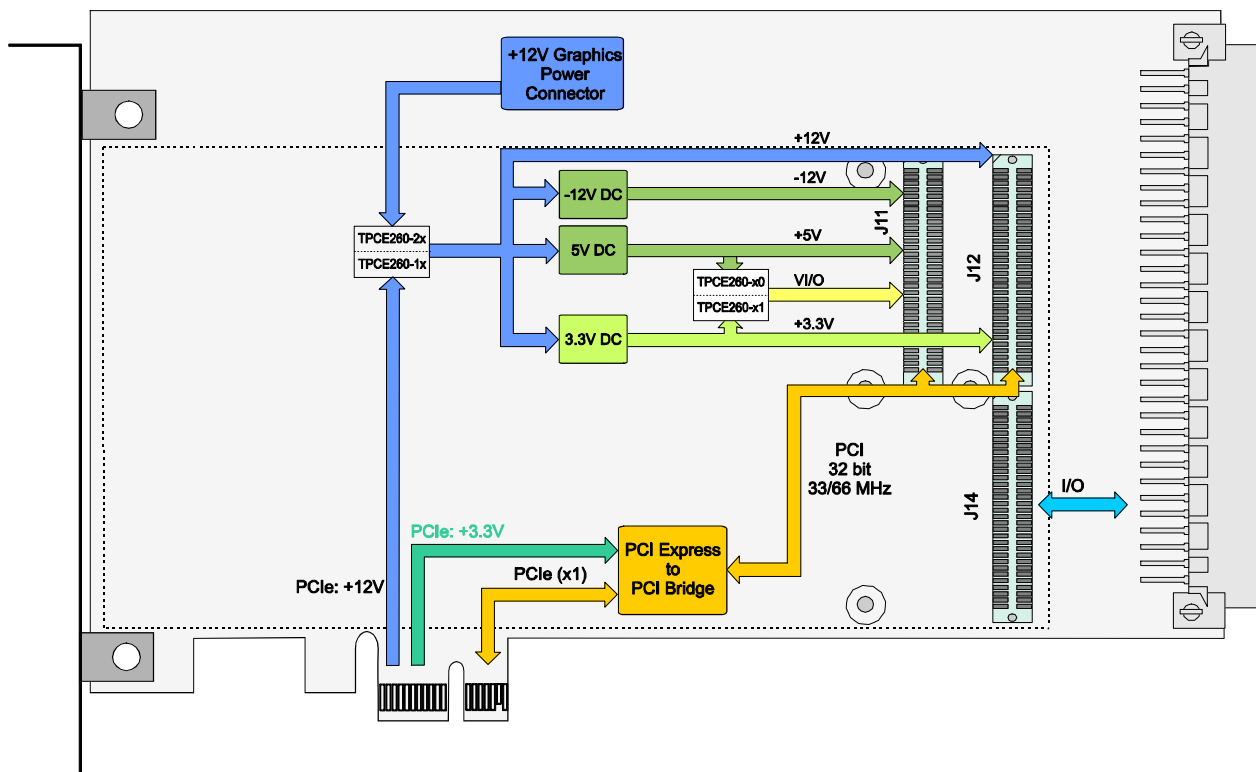

Figure 1-1 : Block Diagram

## 2 Technical Specification

<b>Mechanical and Electrical Interfaces</b>	
<b>PCI Express</b>	PCI Express x1, Revision 1.1 Standard Height Full Length
<b>PCI (PMC Slot)</b>	PCI Mezzanine Card (PMC) Interface conforming to IEEE P1386/P1386.1 Single Size PCI Rev. 3.0 compliant 33/66 MHz / 32-Bit PCI 3.3V and 5V PCI Signaling Voltage
<b>PMC Interface</b>	
<b>Number of PMC Slots</b>	1
<b>PMC I/O Access</b>	PMC Front Panel I/O PMC P14 Back I/O through VG64 Right Angle Male Connector
<b>On Board Devices</b>	
<b>PCI Express to PCI Bridge</b>	PI7C9X111SL (Pericom)
<b>Physical Data</b>	
<b>Power Requirements</b>	250mA typical @ +3.3V DC 50mA typical @ +12V DC <b>Additional power is required by the PMC Module!</b>
<b>Maximum Power for PMC Slot</b>	<u>TPCE260-1xR:</u> 3 A maximum @ +3.3V DC 2 A maximum @ +5V DC 200 mA maximum @ +12V DC 200 mA maximum @ -12V DC  <u>TPCE260-2xR:</u> 5 A maximum @ +3.3V DC 5 A maximum @ +5V DC 200 mA maximum @ +12V DC 200 mA maximum @ -12V DC
<b>Temperature Range</b>	Operating    -40°C to +85°C Storage       -40°C to +85°C
<b>MTBF</b>	TPCE260-1xR: 664000 h TPCE260-2xR: 582000 h MTBF values shown are based on calculation according to MIL-HDBK-217F and MIL-HDBK-217F Notice 2; Environment: G <sub>B</sub> 20°C. The MTBF calculation is based on component FIT rates provided by the component suppliers. If FIT rates are not available, MIL-HDBK-217F and MIL-HDBK-217F Notice 2 formulas are used for FIT rate calculation.
<b>Humidity</b>	5 – 95 % non-condensing
<b>Weight</b>	TPCE260-1xR: 99 g TPCE260-2xR: 101 g

Table 2-1 : Technical Specification

## 3 Handling and Operating Instructions

### 3.1 ESD Protection



The TPCE260 is sensitive to static electricity. Packing, unpacking and all other handling of the TPCE260 has to be done in an ESD/EOS protected Area.

### 3.2 PCI Bus Signaling Voltage and Keying



Be sure that the TPCE260 PCI bus signal voltage configuration matches the TPCE260 PMC slots keying pin configuration. If PMC modules are plugged into a PCI environment where the PCI signaling voltage does not match, damage to the equipment could occur, voiding product warranties. Refer to the chapter “PCI Signaling Voltage” for details.

### 3.3 Power Limits for PMC Modules



The PCIe specification limits the power for PCIe add-in cards. These limitations have implications for the use of PMC modules. Refer to the chapter “Power Limits for PMC Modules” for details.

### 3.4 Installation of PMC Modules



Before mounting PMC Modules on the TPCE260, be sure that the system is powered off. Also, follow the installation instructions in the “PMC Interface” chapter.

### 3.5 Installation of TPCE260-2xR



For the TPCE260-2xR variants, it is imperative to always connect a PCI Express VGA power connector to the TPCE260, even if no PMC is mounted.



## 4 PCIe-to-PCI Bridge

### 4.1 PCI Configuration Registers

#### 4.1.1 PCIe-to-PCI Bridge Configuration Space Header

PCI CFG Register Address	PCI Configuration Registers							Initial Values (Hex Values)	
	31	24	23	16	15	8	7		0
0x00	Device ID				Vendor ID				E111 12D8
0x04	Status				Command				0010 0000
0x08	Class Code					Revision ID			060400 02
0x0C	BIST		Header Type		Primary Latency Timer		Cacheline Size		00 01 00 00
0x10	Reserved							-	
0x14	Reserved							-	
0x18	Secondary Latency Timer		Subordinate Bus Number		Secondary Bus Number		Primary Bus Number		00 00 00 00
0x1C	Secondary Status				I/O Limit		I/O Base		02A0 01 01
0x20	Memory Limit				Memory Base				0000 8000
0x24	Prefetchable Memory Limit				Prefetchable Memory Base				0001 8001
0x28	Prefetchable Base Upper 32-Bit							00000000	
0x2C	Prefetchable Limit Upper 32-Bit							00000000	
0x30	I/O Limit Upper 16-Bit				I/O Base Upper 16-Bit				0000 0000
0x34	Reserved					Capability Pointer			000000 80
0x38	Expansion ROM Base Address							00000000	
0x3C	Bridge Control				Interrupt Pin		Interrupt Line		00 00 01 00

Table 4-1 : PCIe-to-PCI Bridge Configuration Space Header

## 4.2 PCI Bus Device Number Mapping

The PCI bus device number of the PMC slot is defined by configuration type translation of the PCI-Express to PCI Bridge.

By default, the PMC slot is mapped to the bus device number 0x0.

PCI Bus Device Number (HEX)	PCI AD Line used as PMC IDSEL	Purpose
0x0	16	Default IDSEL for PMC Slot
0x1	17	Not used on TPCE260
0x2	18	
0x3	19	
0x4	20	Optional IDSEL for PMC Slot
0x5	21	Not used on TPCE260
-	-	
0xF	31	

Table 4-2 : PCI Bus Device Number Mapping

## 4.3 PCI Clock Frequency

The TPCE260 supports 66 MHz PCI clock frequency. The actual PCI clock frequency on the TPCE260 is configured by the plugged PMC module. If the plugged PMC module supports 66 MHz operation, the PCI bus will operate with 66 MHz; otherwise it will operate with 33 MHz.

## 5 PMC Interface

### 5.1 PMC BUSMODE[4:1] Signals

The BUSMODE[4:1]# signals are defined in the IEEE1386 (CMC) specification and allow a host to identify the used mezzanine card type. The TPCE260 supports PMC cards only.

The TPCE260 indicates the “PMC only” support with the signal levels presented in the table below. The PMC card should decode these signals and drive out a logic “0” on BUSMODE1#.

Signal	Logic Level
BUSMODE4#	Pulled LOW
BUSMODE3#	Pulled LOW
BUSMODE2#	Pulled HIGH

Table 5-1 : TPCE260 PMC BUSMODE[4:1] Signals

### 5.2 PCI Signaling Voltage

PMC modules are specified either for 3.3V only, 5V only or universal (3.3V or 5V) PCI signaling voltage operation.

The TPCE260 onboard V\_I/O voltage level defines the PCI signaling voltage level for the TPCE260 PCI bus. A voltage keying pin indicates the voltage level and prevents incompatible PMC modules from being plugged onto the carrier.

TPCE260	V_I/O Configuration	5V Keying Pin	3.3V Keying Pin
-x0	5V	Installed	Not Installed
-x1	3.3V	Not Installed	Installed

Table 5-2 : TPCE260 PCI Signaling Voltage Factory Defaults

#### 5.2.1 V\_I/O Configuration

The V\_I/O signaling voltage level is configured by three resistors. To change the voltage level, these resistors must be soldered to the appropriate soldering terminals. They are grouped and labeled appropriately.



Figure 5-1 : PCI Signaling Voltage Configuration Resistors

TPCE260 V_I/O	Populated Resistors	Unpopulated Resistors
5V	R500, R501, R502	R300, R301, R302
3.3V	R300, R301, R302	R500, R501, R502

Table 5-3 : PCI Signaling Voltage Configuration Resistors

## 5.2.2 Voltage Keying Configuration

To prevent a PMC module from being plugged into a PMC system with a different PCI signaling voltage, the PMC specification defines a voltage keying system with keying pins (on the PMC carrier board) and keying holes (on the PMC module).

PMC modules supporting only 5V PCI signaling voltage provide a single keying hole for the 5V keying pin.

PMC modules supporting only 3.3V PCI signaling voltage provide a single keying hole for the 3.3V keying pin.

Universal PMC modules supporting both 3.3V and 5V PCI signaling voltages provide keying holes for both voltage keying pins.

In certain system configurations it may be necessary to remove the keying pin from one location and assemble it at the other keying pin location.

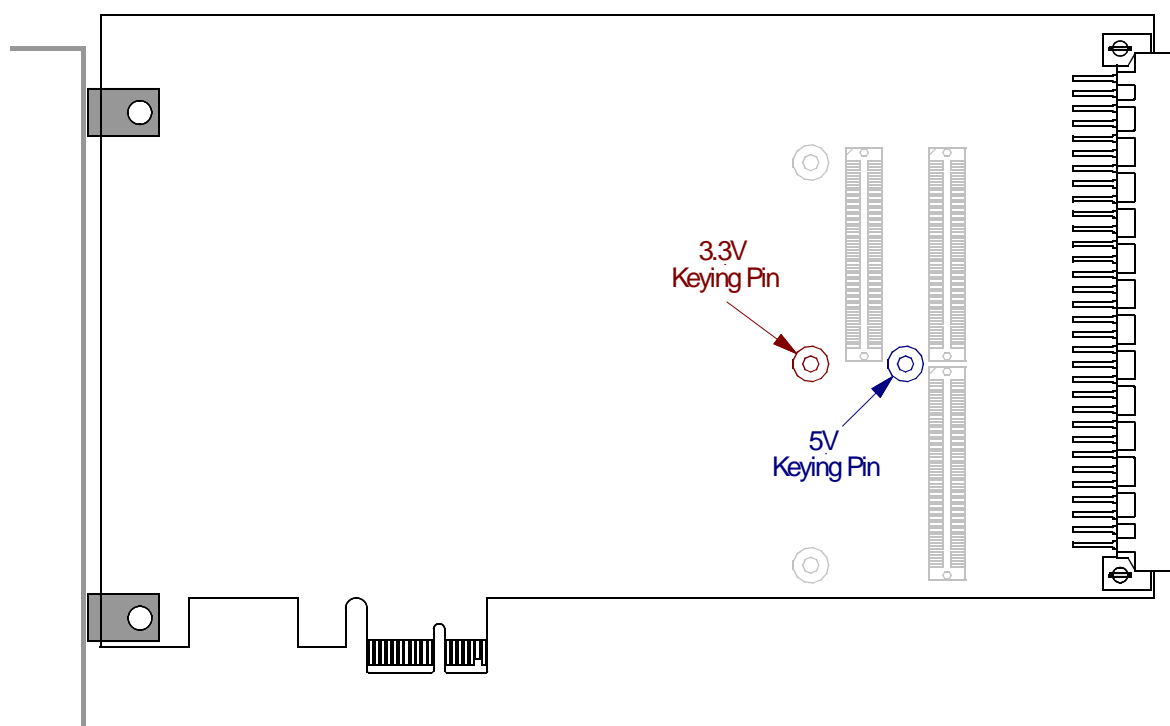

Figure 5-2 : PMC Voltage Keying

Use the following table to identify the required TPCE260 voltage keying for the actual PMC modules that are to be used.

PMC PCI Signaling Voltage Capability	TPCE260 V_I/O Configuration	TPCE260 5V Keying Pin	TPCE260 3.3V Keying Pin
3.3V only	3.3V	Not Installed	Installed
3.3V or 5V	3.3V	Not Installed	Installed
	5V	Installed	Not Installed
5V only	5V	Installed	Not Installed

Table 5-4 : PCI Signal Voltage Configuration Matrix

## 5.3 Power Limits for PMC Modules

The following current limits have to be taken into account when choosing the appropriate TPCE260 for the power requirements of the PMC module.

TPCE260	Voltage	Current Limits
TPCE260-1xR	+3.3V	3 A
	+5V	2 A
	+12V	200 mA
	-12V	200 mA
TPCE260-2xR	+3.3V	5 A
	+5V	5 A
	+12V	200 mA
	-12V	200 mA

Table 5-5 : Current Limits for the PMC Modules

## 5.4 Installation of a PMC Module

The PMC modules are mounted to the TPCE260 prior to installation into the system.

If the PMC has a front panel, first remove the cover from the PMC front panel cut-out of the TPCE260. Install the PMC at an angle so that the PMC front panel penetrates the PMC front panel cut-out. Then rotate down to mate with the PMC connectors on the TPCE260. If the PMC has no front panel, simply plug in the PMC, and leave the cover in the PMC front panel cut-out of the TPCE260.

After the PMC module has been installed, it can be mounted on the TPCE260 using the mounting screws that come with the PMC module. There are four screw mounting locations, two at the PMC front panel and two at the standoffs near the PMC bus connectors.

**Before installing a PMC module, be sure that the power supply for the TPCE260 is turned off.**

**The components are Electrostatic Sensitive Devices (ESD). Use an anti-static mat connected to a wristband when handling or installing the components.**

**WARNING!!!**

**Be sure that the TPCE260 PCI bus signaling voltage (V\_I/O) configuration matches the TPCE260 PMC slots keying pin configuration.**

**Be sure that the used PMC modules match the TPCE260 PCI bus signaling voltage and PMC slot keying pin configuration.**

**If PMC modules are plugged into a PCI environment where the PCI signaling voltage does not match, damage to the equipment could occur, voiding product warranties.**

## 6 Pin Assignments

### 6.1 PMC J11 / P11

Pin	Signal		Signal	Pin
1	TCK		-12V	2
3	GND		INTA#	4
5	INTB#		INTC#	6
7	BUSMODE1#		+5V	8
9	INTD#		PCI-RSVD	10
11	GND		3.3Vaux	12
13	CLK		GND	14
15	GND		GNT#	16
17	REG#		+5V	18
19	V (I/O)		AD[31]	20
21	AD[28]		AD[27]	22
23	AD[25]		GND	24
25	GND		C/BE[3]#	26
27	AD[22]		AD[21]	28
29	AD[19]		+5V	30
31	V (I/O)		AD[17]	32
33	FRAME#		GND	34
35	GND		IRDY#	36
37	DEVSEL#		+5V	38
39	GND		LOCK#	40
41	PCI-RSVD		PCI-RSVD	42
43	PAR		GND	44
45	V (I/O)		AD[15]	46
47	AD[12]		AD[11]	48
49	AD[09]		+5V	50
51	GND		C/BE[0]#	52
53	AD[06]		AD[05]	54
55	AD[04]		GND	56
57	V (I/O)		AD[03]	58
59	AD[02]		AD[01]	60
61	AD[00]		+5V	62
63	GND		REQ64#	64

Table 6-1 : PMC J11/P11 Pin Assignment

## 6.2 PMC J12 / P12

Pin	Signal		Signal	Pin
1	+12V		TRST#	2
3	TMS		TDO	4
5	TDI		GND	6
7	GND		PCI-RSVD	8
9	PCI-RSVD		PCI-RSVD	10
11	BUSMODE2#		+3.3V	12
13	RST#		BUSMODE3#	14
15	+3.3V		BUSMODE4#	16
17	PME#		GND	18
19	AD[30]		AD[29]	20
21	GND		AD[26]	22
23	AD[24]		+3.3V	24
25	IDSEL		AD[23]	26
27	+3.3V		AD[20]	28
29	AD[18]		GND	30
31	AD[16]		C/BE[2]#	32
33	GND		PMC-RSVD	34
35	TRDY#		+3.3V	36
37	GND		STOP#	38
39	PERR#		GND	40
41	+3.3V		SERR#	42
43	C/BE[1]#		GND	44
45	AD[14]		AD[13]	46
47	M66EN		AD[10]	48
49	AD[08]		+3.3V	50
51	AD[07]		PMC-RSVD	52
53	+3.3V		PMC-RSVD	54
55	PMC-RSVD		GND	56
57	PMC-RSVD		PMC-RSVD	58
59	GND		PMC-RSVD	60
61	ACK64#		+3.3V	62
63	GND		PMC-RSVD	64

Table 6-2 : PMC J12/P12 Pin Assignment

## 6.3 PMC J14 / P14

The PMC J14 / P14 connector routes the PMC I/O lines directly to its appropriate pins. The actual signal assignment is PMC specific.

Pin	Signal		Signal	Pin
1	I/O 1		I/O 2	2
3	I/O 3		I/O 4	4
5	I/O 5		I/O 6	6
7	I/O 7		I/O 8	8
9	I/O 9		I/O 10	10
11	I/O 11		I/O 12	12
13	I/O 13		I/O 14	14
15	I/O 15		I/O 16	16
17	I/O 17		I/O 18	18
19	I/O 19		I/O 20	20
21	I/O 21		I/O 22	22
23	I/O 23		I/O 24	24
25	I/O 25		I/O 26	26
27	I/O 27		I/O 28	28
29	I/O 29		I/O 30	30
31	I/O 31		I/O 32	32
33	I/O 33		I/O 34	34
35	I/O 35		I/O 36	36
37	I/O 37		I/O 38	38
39	I/O 39		I/O 40	40
41	I/O 41		I/O 42	42
43	I/O 43		I/O 44	44
45	I/O 45		I/O 46	46
47	I/O 47		I/O 48	48
49	I/O 49		I/O 50	50
51	I/O 51		I/O 52	52
53	I/O 53		I/O 54	54
55	I/O 55		I/O 56	56
57	I/O 57		I/O 58	58
59	I/O 59		I/O 60	60
61	I/O 61		I/O 62	62
63	I/O 63		I/O 64	64

Table 6-3 : PMC J14/P14 Pin Assignment



## 6.4 X4 VG64 Rear-I/O Connector

The PMC J14 / P14 I/O connector routes the PMC I/O lines to the VG64 Right Angle Male, Type C connector compliant to VITA-35 (“PMC P4 to VME-P2, Rows A-C mapping”). The actual signal assignment of the PMC J14 / P14 connector is PMC specific.

Pin	Signal		Signal	Pin
c1	I/O 1		I/O 2	a1
c2	I/O 3		I/O 4	a2
c3	I/O 5		I/O 6	a3
c4	I/O 7		I/O 8	a4
c5	I/O 9		I/O 10	a5
c6	I/O 11		I/O 12	a6
c7	I/O 13		I/O 14	a7
c8	I/O 15		I/O 16	a8
c9	I/O 17		I/O 18	a9
c10	I/O 19		I/O 20	a10
c11	I/O 21		I/O 22	a11
c12	I/O 23		I/O 24	a12
c13	I/O 25		I/O 26	a13
c14	I/O 27		I/O 28	a14
c15	I/O 29		I/O 30	a15
c16	I/O 31		I/O 32	a16
c17	I/O 33		I/O 34	a17
c18	I/O 35		I/O 36	a18
c19	I/O 37		I/O 38	a19
c20	I/O 39		I/O 40	a20
c21	I/O 41		I/O 42	a21
c22	I/O 43		I/O 44	a22
c23	I/O 45		I/O 46	a23
c24	I/O 47		I/O 48	a24
c25	I/O 49		I/O 50	a25
c26	I/O 51		I/O 52	a26
c27	I/O 53		I/O 54	a27
c28	I/O 55		I/O 56	a28
c29	I/O 57		I/O 58	a29
c30	I/O 59		I/O 60	a30
c31	I/O 61		I/O 62	a31
c32	I/O 63		I/O 64	a32

Table 6-4 : X4 VG64 Pin Assignment