

The Embedded I/O Company



TPMC895

Dual/Four Channel 10/100/1000 Mbit/s Ethernet

Version 1.0

User Manual

Issue 1.0.1

December 2021



Ehlbeek 15a
30938 Burgwedel
fon 05139-9980-0
fax 05139-9980-49

www.powerbridge.de
info@powerbridge.de

TEWS TECHNOLOGIES GmbH

Am Bahnhof 7 25469 Halstenbek, Germany
Phone: +49 (0) 4101 4058 0 Fax: +49 (0) 4101 4058 19
e-mail: info@tews.com www.tews.com

TPMC895-10R

Four Channel 10/100/1000 Mbit/s Ethernet, Intel I210IT, RJ45

(RoHS compliant)

TPMC895-11R

Four Channel 10/100/1000 Mbit/s Ethernet, Intel I210IT, P14 Back I/O

(RoHS compliant)

TPMC895-20R

Two Channel 10/100/1000 Mbit/s Ethernet, Intel I210IT, RJ45

(RoHS compliant)

TPMC895-21R

Two Channel 10/100/1000 Mbit/s Ethernet, Intel I210IT, P14 Back I/O

(RoHS compliant)

TPMC895-30R

Four Channel 10/100/1000 Mbit/s Ethernet, Intel I210IT, RJ45, IEEE 1588 auxiliary devices via P14

(RoHS compliant)

This document contains information, which is proprietary to TEWS TECHNOLOGIES GmbH. Any reproduction without written permission is forbidden.

TEWS TECHNOLOGIES GmbH has made any effort to ensure that this manual is accurate and complete. However, TEWS TECHNOLOGIES GmbH reserves the right to change the product described in this document at any time without notice.

TEWS TECHNOLOGIES GmbH is not liable for any damage arising out of the application or use of the device described herein.

©2021 by TEWS TECHNOLOGIES GmbH

All trademarks mentioned are property of their respective owners.

Issue	Description	Date
1.0.0	Initial issue	January 2021
1.0.1	Issue after Revision Update to V1.0 Rev.B	December 2021

Table of Contents

1	PRODUCT DESCRIPTION	6
2	TECHNICAL SPECIFICATION	8
3	HANDLING AND OPERATION INSTRUCTIONS	10
3.1	ESD Protection	10
3.2	Power Dissipation	10
4	PCI INTERFACE	11
4.1	TPMC895 PCI Device Topology	11
4.2	TPMC895 PCI Memory and I/O Size Requirements	11
4.3	I210 PCI Identifiers	12
4.4	I210 PCI Base Address Register Configuration	12
5	ETHERNET INTERFACE STATUS LEDS	13
6	SYNCHRONIZATION WITH IEEE 1588 AUXILIARY DEVICES	13
7	PIN ASSIGNMENT – I/O CONNECTORS	14
7.1	RJ45 Connector	14
7.2	Back I/O P14 Connector (TPMC895-11R)	14
7.3	Back I/O P14 Connector (TPMC895-21R)	15
7.4	Back I/O P14 Connector (TPMC895-30R)	16

List of Figures

FIGURE 1-1 : BLOCK DIAGRAM RJ45	7
FIGURE 1-2 : BLOCK DIAGRAM P14 BACK I/O	7
FIGURE 4-1 : TPMC895 PCI DEVICE TOPOLOGY.....	11

List of Tables

TABLE 2-1 : TECHNICAL SPECIFICATION.....	9
TABLE 4-1 : TPMC895 PCI MEMORY AND I/O SIZE REQUIREMENTS.....	11
TABLE 4-2 : I210 PCI IDENTIFIERS	12
TABLE 4-3 : I210 PCI BASE ADDRESS REGISTER CONFIGURATION.....	12
TABLE 5-1 : STATUS LED.....	13
TABLE 6-1 : ELECTRICAL CHARACTERISTICS OF ETHERNET CONTROLLERS' GPIO PINS.....	13
TABLE 7-1 : RJ45 CONNECTOR	14
TABLE 7-2 : BACK I/O P14 CONNECTOR (TPMC895-11R).....	14
TABLE 7-3 : BACK I/O P14 CONNECTOR (TPMC895-21R).....	15
TABLE 7-4 : BACK I/O P14 CONNECTOR (TPMC895-30R).....	16

1 Product Description

The TPMC895 is a PCI Mezzanine Card (PMC) compatible module providing a dual or four channel Ethernet 10Base-T / 100Base-TX / 1000Base-T interface.

A transparent 64 bit, up to 133 MHz PCI-X/PCI to PCIe Bridge and a PCIe Switch provide access to the Intel I210IT Gigabit Ethernet controllers. Each Ethernet interface supports 10, 100 and 1000 Mbit/s transmission rates and is equipped with a 16 Mbit Serial Flash to support PXE and iSCSI boot.

The two/four Ethernet interfaces of the TPMC895 are capable of performing an auto negotiation algorithm which allows both link-partners to determine the best link-parameters. The TPMC895 supports IEEE 1588/802.1AS Precision Time Protocol (PTP) and IEEE 802.1Qav Audio/Video Bridging (AVB) traffic shaping (with software extensions).

The TPMC895-10R provides four 10/100/1000 Mbit/s Ethernet connections via front panel RJ45 connectors.

The TPMC895-11R routes four Ethernet ports to the Back I/O P14 connector without any RJ45 connector at the front.

The TPMC895-20R provides two 10/100/1000 Mbit/s Ethernet connections via front panel RJ45 connectors.

The TPMC895-21R routes two Ethernet ports to the Back I/O P14 connector without any RJ45 connector at the front.

The TPMC895-30R is a TPMC895-10R with an additional Back I/O P14 connector for IEEE 1588 auxiliary device connections.

All ports are galvanically isolated from the Ethernet controllers and LEDs on the board indicate the different network activities.

The module meets the requirements to operate in extended temperature range from -40°C to +85°C.

Software Support:

- Software support for Intel I210IT at www.intel.com
- For operating systems not supported by Intel, please contact TEWS.

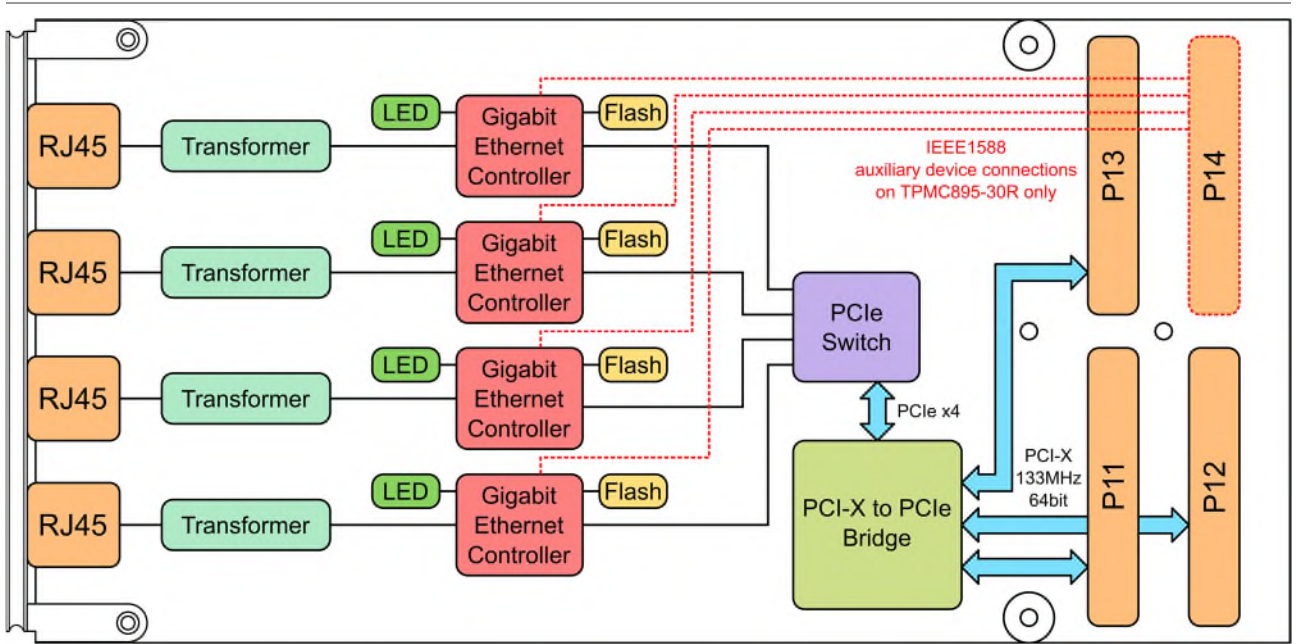

Figure 1-1 : Block Diagram RJ45

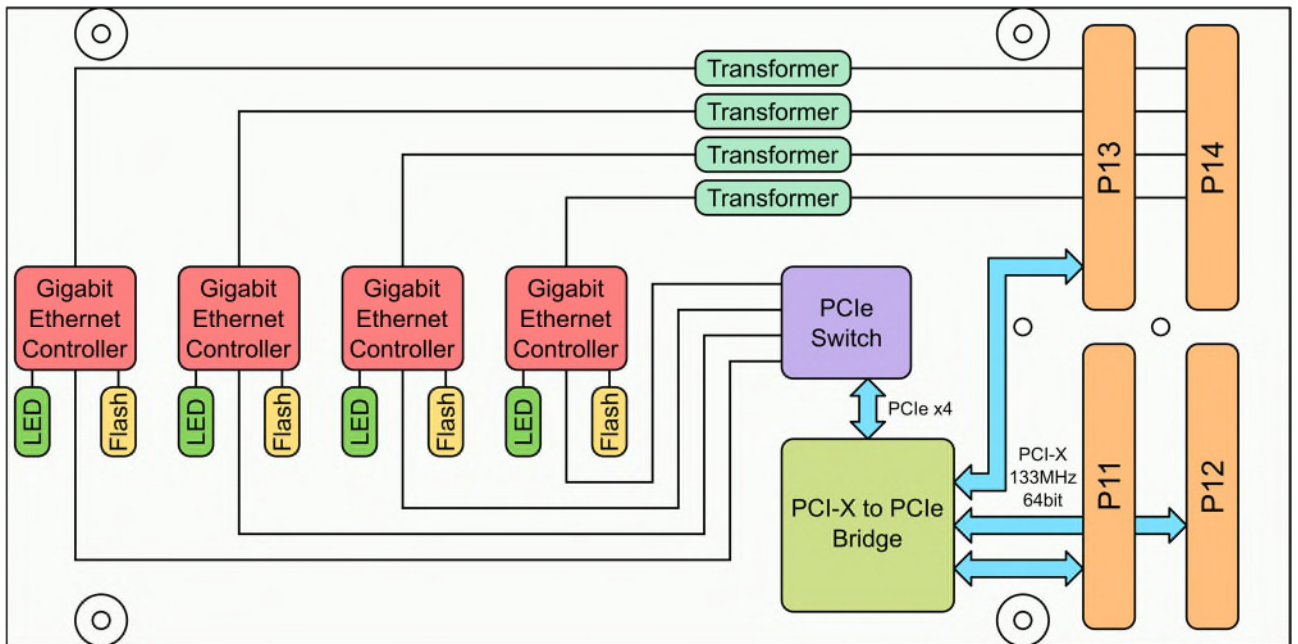

Figure 1-2 : Block Diagram P14 Back I/O

2 Technical Specification

PMC Interface	
Mechanical Interface	PCI Mezzanine Card (PMC) Interface conforming to IEEE P1386/P1386.1 Standard single-width (149 mm x 74 mm)
Electrical Interface	64 bit PCI (Specification 3.0) up to 66 MHz and 64 bit PCI-X (Specification 2.0a) up to 133 MHz compliant interface conforming to 3.3V PCI signaling with 5V I/O tolerance

On Board Devices	
PCI/PCI-X to PCIe Bridge	PI7C9X130 (Diodes Incorporated)
PCIe Switch	PI7C9X2G608GP (Diodes Incorporated)
Gigabit Ethernet Controllers	For each interface: I210-IT (Intel)
16 Mbit Serial Flashes for Boot ROM	For each interface: W25Q16JV (Winbond)

I/O Interface	
Number of Channels	2/4
I/O Standards	1000Base-T 100Base-TX 10Base-T
I/O Connector	TPMC895-x0R: RJ45 (TE Connectivity 406732 or compatible) TPMC895-x1R: Back I/O P14 (Molex 714362864 or compatible)

Physical Data	
Power Requirements	1000mA typical @ +5V (four channel, no link) app. additional 10mA to 100mA per link
Temperature Range	Operating -40°C to +85°C (constant airflow of 2m/s is required) Storage -40°C to +85°C
MTBF	TPMC895-10R: 427000 h TPMC895-11R: 587000 h TPMC895-20R: 593000 h TPMC895-21R: 679000 h TPMC895-30R: 389000 h MTBF values shown are based on calculation according to MIL-HDBK-217F and MIL-HDBK-217F Notice 2; Environment: G _B 20°C. The MTBF calculation is based on component FIT rates provided by the component suppliers. If FIT rates are not available, MIL-HDBK-217F and MIL-HDBK-217F Notice 2 formulas are used for FIT rate calculation.
Humidity	5 – 95 % non-condensing

Weight	TPMC895-10R: 83 g TPMC895-11R: 72 g TPMC895-20R: 73 g TPMC895-21R: 69 g TPMC895-30R: 85 g
---------------	---

Table 2-1 : Technical Specification

3 Handling and Operation Instructions

3.1 ESD Protection



This PMC module is sensitive to static electricity.
Packing, unpacking and all other module handling has to be done with appropriate care.

3.2 Power Dissipation



This PMC module requires adequate forced air cooling!

4 PCI Interface

4.1 TPMC895 PCI Device Topology

The TPMC895 uses two/four Gigabit Ethernet Controllers (Intel I210-IT) each communicating via a PCIe Rev. 2.1 compliant x1 Interface.

To be able to access the Ethernet controllers they are connected to the x1 Downstream Ports of a PCIe Switch (Diodes Incorporated PI7C9X2G608GP).

The x4 Upstream Port of the PCIe Switch is connected to a PCI/PCI-X to PCIe Bridge (Diodes Incorporated PI7C9X130) which communicates with the host system.

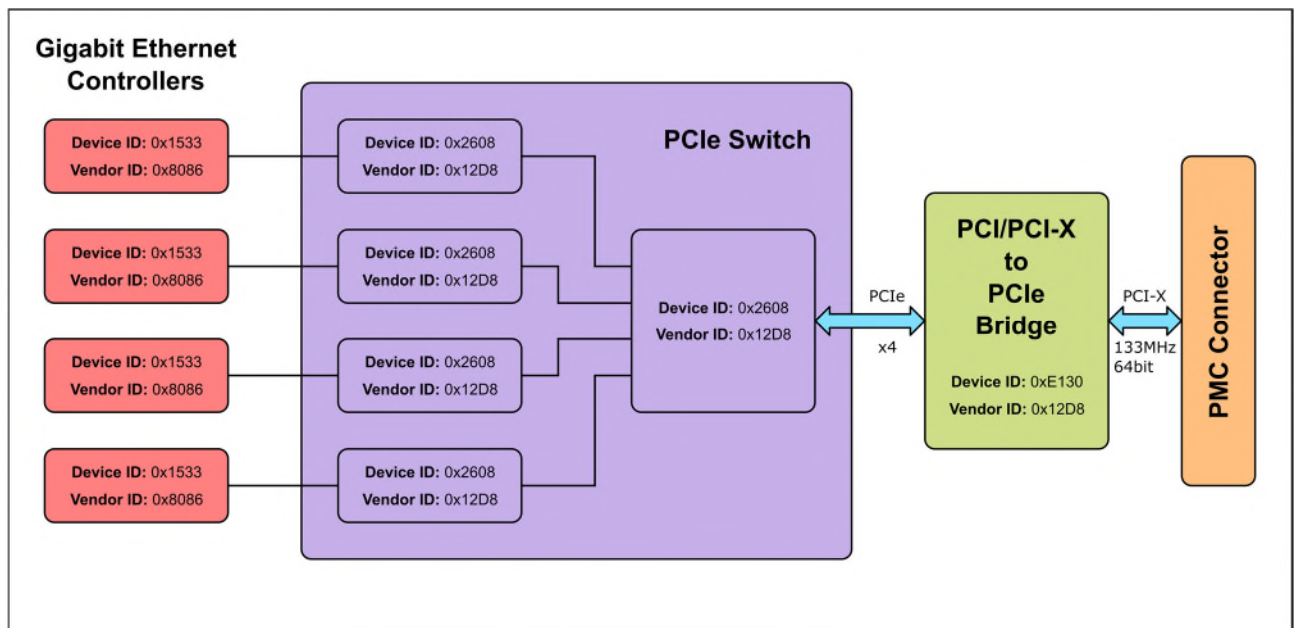

Figure 4-1 : TPMC895 PCI Device Topology

4.2 TPMC895 PCI Memory and I/O Size Requirements

PCI Space Mapping	Four Channel (Byte)	Two Channel (Byte)
MEM	4M	2M
I/O	16K	8K

Table 4-1 : TPMC895 PCI Memory and I/O Size Requirements

4.3 I210 PCI Identifiers

Vendor-ID	0x8086 (Intel)
Device-ID	0x1533 (I210-IT copper only)
Class Code	0x020000 (Ethernet Controller)
Subsystem Vendor-ID	0xFFFF
Subsystem Device-ID	0x0000

Table 4-2 : I210 PCI Identifiers

4.4 I210 PCI Base Address Register Configuration

PCI Base Address Register (Offset in PCI Configuration Space)	PCI Space Mapping	Size (Byte)	Description
0 (0x10)	MEM	128K	Internal Registers
1 (0x14)	-	-	-
2 (0x18)	I/O	32	Internal Registers via I/O Space
3 (0x1C)	MEM	16K	MSI-X

Table 4-3 : I210 PCI Base Address Register Configuration

5 Ethernet Interface Status LEDs

The TPMC895 provides an individual Status LED for every Ethernet Interface. Due to the fact that PMCs are mounted upside-down on the carrier card the Status LEDs are visible on the back side of the TPMC895. A marking is placed close to each Status LED to indicate the Ethernet Port it corresponds to.

See table below for more details:

Status LED	Description
OFF	No cable is connected or no link is established
ON	A link is established
BLINKING	Activity (the Ethernet Port transmits or receives data)

Table 5-1 : Status LED

6 Synchronization with IEEE 1588 Auxiliary Devices

The TPMC895 supports IEEE 1588/802.1AS Precision Time Protocol (PTP).

If you additionally want to synchronize with IEEE 1588 auxiliary devices, this can be realized with TPMC895-30R via the Ethernet Controllers' GPIO Software-Definable Pins (SDPx) that are connected to the Back I/O P14 connector.

The electrical characteristics of the Ethernet Controllers' GPIO Pins are listed in the following table:

Symbol	Parameter	Conditions	Min	Max	Units
V _{OH}	Output High Voltage	I _{OH} = -8 mA; VCC3P3 = Min	2.4		V
		I _{OH} = -100 µA; VCC3P3 = Min	VCC3P3 - 0.2		V
V _{OL}	Output Low Voltage	I _{OL} = 8 mA; VCC = Min		0.4	V
		I _{OL} = 100 µA; VCC = Min		0.2	V
V _{IH}	Input High Voltage		0.7 * VCC3P3	VCC3P3 + 0.4	V
V _{IL}	Input Low Voltage		-0.4	0.3 * VCC3P3	V

Table 6-1 : Electrical characteristics of Ethernet Controllers' GPIO Pins

7 Pin Assignment – I/O Connectors

7.1 RJ45 Connector

	Pin	Signal (1000Base-T)	Signal (100Base-TX/10Base-T)
	1	TX0/RX0+	TX+
2	TX0/RX0-	TX-	
3	TX1/RX1+	RX+	
4	TX2/RX2+	not used	
5	TX2/RX2-	not used	
6	TX1/RX1-	RX-	
7	TX3/RX3+	not used	
8	TX3/RX3-	not used	

Table 7-1 : RJ45 Connector

7.2 Back I/O P14 Connector (TPMC895-11R)

Signal	Pin		Pin	Signal
TERM PLANE	63		64	TERM PLANE
ETHERNET 2 TX3/RX3-	61	62	ETHERNET 1 TX3/RX3-	
ETHERNET 2 TX3/RX3+	59	60	ETHERNET 1 TX3/RX3+	
TERM PLANE	57	58	TERM PLANE	
ETHERNET 2 TX2/RX2-	55	56	ETHERNET 1 TX2/RX2-	
ETHERNET 2 TX2/RX2+	53	54	ETHERNET 1 TX2/RX2+	
TERM PLANE	51	52	TERM PLANE	
ETHERNET 1 TX0/RX0-	49	50	ETHERNET 1 TX1/RX1-	
TERM PLANE	47	48	TERM PLANE	
ETHERNET 1 TX0/RX0+	45	46	ETHERNET 1 TX1/RX1+	
TERM PLANE	43	44	TERM PLANE	
TERM PLANE	41	42	TERM PLANE	
ETHERNET 2 TX0/RX0-	39	40	ETHERNET 2 TX1/RX1-	
TERM PLANE	37	38	TERM PLANE	
ETHERNET 2 TX0/RX0+	35	36	ETHERNET 2 TX1/RX1+	
TERM PLANE	33	34	TERM PLANE	
TERM PLANE	31	32	TERM PLANE	
ETHERNET 3 TX0/RX0-	29	30	ETHERNET 3 TX1/RX1-	
TERM PLANE	27	28	TERM PLANE	
ETHERNET 3 TX0/RX0+	25	26	ETHERNET 3 TX1/RX1+	
TERM PLANE	23	24	TERM PLANE	
TERM PLANE	21	22	TERM PLANE	
ETHERNET 4 TX0/RX0-	19	20	ETHERNET 4 TX1/RX1-	
TERM PLANE	17	18	TERM PLANE	
ETHERNET 4 TX0/RX0+	15	16	ETHERNET 4 TX1/RX1+	
TERM PLANE	13	14	TERM PLANE	
ETHERNET 4 TX2/RX2-	11	12	ETHERNET 3 TX2/RX2-	
ETHERNET 4 TX2/RX2+	9	10	ETHERNET 3 TX2/RX2+	
TERM PLANE	7	8	TERM PLANE	
ETHERNET 4 TX3/RX3-	5	6	ETHERNET 3 TX3/RX3-	
ETHERNET 4 TX3/RX3+	3	4	ETHERNET 3 TX3/RX3+	
TERM PLANE	1	2	TERM PLANE	

Table 7-2 : Back I/O P14 Connector (TPMC895-11R)

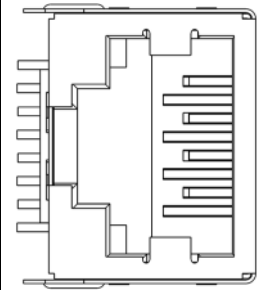
7.3 Back I/O P14 Connector (TPMC895-21R)

Signal	Pin	Pin	Signal
TERM_PLANE	63	64	TERM_PLANE
ETHERNET_2_TX3/RX3-	61	62	ETHERNET_1_TX3/RX3-
ETHERNET_2_TX3/RX3+	59	60	ETHERNET_1_TX3/RX3+
TERM_PLANE	57	58	TERM_PLANE
ETHERNET_2_TX2/RX2-	55	56	ETHERNET_1_TX2/RX2-
ETHERNET_2_TX2/RX2+	53	54	ETHERNET_1_TX2/RX2+
TERM_PLANE	51	52	TERM_PLANE
ETHERNET_1_TX0/RX0-	49	50	ETHERNET_1_TX1/RX1-
TERM_PLANE	47	48	TERM_PLANE
ETHERNET_1_TX0/RX0+	45	46	ETHERNET_1_TX1/RX1+
TERM_PLANE	43	44	TERM_PLANE
TERM_PLANE	41	42	TERM_PLANE
ETHERNET_2_TX0/RX0-	39	40	ETHERNET_2_TX1/RX1-
TERM_PLANE	37	38	TERM_PLANE
ETHERNET_2_TX0/RX0+	35	36	ETHERNET_2_TX1/RX1+
TERM_PLANE	33	34	TERM_PLANE
TERM_PLANE	31	32	TERM_PLANE
NC	29	30	NC
TERM_PLANE	27	28	TERM_PLANE
NC	25	26	NC
TERM_PLANE	23	24	TERM_PLANE
TERM_PLANE	21	22	TERM_PLANE
NC	19	20	NC
TERM_PLANE	17	18	TERM_PLANE
NC	15	16	NC
TERM_PLANE	13	14	TERM_PLANE
NC	11	12	NC
NC	9	10	NC
TERM_PLANE	7	8	TERM_PLANE
NC	5	6	NC
NC	3	4	NC
TERM_PLANE	1	2	TERM_PLANE

Table 7-3 : Back I/O P14 Connector (TPMC895-21R)

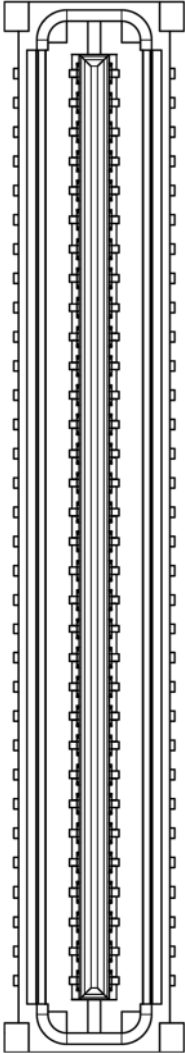
7.4 Back I/O P14 Connector (TPMC895-30R)

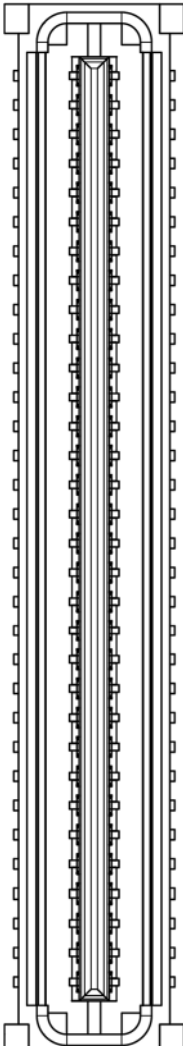
Signal	Pin		Pin	Signal
NC	63		64	NC
NC	61		62	NC
NC	59		60	NC
NC	57		58	NC
NC	55		56	NC
NC	53		54	NC
NC	51		52	NC
NC	49		50	NC
NC	47		48	NC
NC	45		46	NC
NC	43		44	NC
NC	41		42	NC
NC	39		40	NC
NC	37		38	NC
NC	35		36	NC
GND	33		34	ETHERNET 4 SDP3
GND	31		32	ETHERNET 4 SDP2
GND	29		30	ETHERNET 4 SDP1
GND	27		28	ETHERNET 4 SDP0
GND	25		26	ETHERNET 3 SDP3
GND	23		24	ETHERNET 3 SDP2
GND	21		22	ETHERNET 3 SDP1
GND	19		20	ETHERNET 3 SDP0
GND	17		18	ETHERNET 2 SDP3
GND	15		16	ETHERNET 2 SDP2
GND	13		14	ETHERNET 2 SDP1
GND	11		12	ETHERNET 2 SDP0
GND	9		10	ETHERNET 1 SDP3
GND	7		8	ETHERNET 1 SDP2
GND	5		6	ETHERNET 1 SDP1
GND	3		4	ETHERNET 1 SDP0
NC	1		2	NC

Table 7-4 : Back I/O P14 Connector (TPMC895-30R)