

The Embedded I/O Company



TXMC465

8 Channel RS232/RS422/RS485 Programmable Serial Interface

Version 1.0

User Manual

Issue 1.0.3

December 2017



Ehlbeek 15a
30938 Burgwedel
fon 05139-9980-0 www.powerbridge.de
fax 05139-9980-49 info@powerbridge.de

TEWS TECHNOLOGIES GmbH

Am Bahnhof 7 25469 Halstenbek, Germany
Phone: +49 (0) 4101 4058 0 Fax: +49 (0) 4101 4058 19
e-mail: info@tews.com www.tews.com

TXMC465-10R

8 channel programmable serial interface, front panel I/O

TXMC465-20R

8 channel programmable serial interface, front panel I/O, P16 I/O

TXMC465-30R

8 channel programmable serial interface, front panel I/O, P14 I/O

This document contains information, which is proprietary to TEWS TECHNOLOGIES GmbH. Any reproduction without written permission is forbidden.

TEWS TECHNOLOGIES GmbH has made any effort to ensure that this manual is accurate and complete. However TEWS TECHNOLOGIES GmbH reserves the right to change the product described in this document at any time without notice.

TEWS TECHNOLOGIES GmbH is not liable for any damage arising out of the application or use of the device described herein.

Style Conventions

Hexadecimal characters are specified with prefix 0x, i.e. 0x029E (that means hexadecimal value 029E).

For signals on hardware products, an 'Active Low' is represented by the signal name with # following, i.e. IP_RESET#.

Access terms are described as:

W	Write Only
R	Read Only
R/W	Read/Write
R/C	Read/Clear
R/S	Read/Set

©2017 by TEWS TECHNOLOGIES GmbH

All trademarks mentioned are property of their respective owners.

Issue	Description	Date
1.0.0	Initial Issue	July 2015
1.0.1	Clarified "x1" PCIe Interface	February 2016
1.0.2	Added TXMC465-20R (P16 Back I/O) and TXMC465-30R (P14 Back I/O) Variants	March 2016
1.0.3	Correction of Connector View in Table 7-1: Pin Assignment Front Panel I/O Connector	December 2017

Table of Contents

1	PRODUCT DESCRIPTION	6
2	TECHNICAL SPECIFICATION	7
2.1	Compatibility Identification Block	8
3	LOCAL SPACE ADDRESSING	9
3.1	XR17V358 Local Space Configuration	9
3.2	Device Configuration Space	9
3.2.1	UART Register Sets	10
3.2.2	Device Configuration Registers	11
3.2.3	UART Channel Configuration Registers	12
4	XR17V358 TARGET CHIP	14
4.1	PCI Configuration Registers (PCR)	14
4.2	Configuration EEPROM	15
5	CONFIGURATION HINTS.....	18
5.1	CPLD Description.....	18
5.1.1	CPLD Address Map	18
5.1.2	Channel Control Register	18
5.2	CPLD Access	19
5.2.1	Accessing XR17V358 MPIO Pins.....	20
5.2.2	CPLD Bus Protocol	20
5.2.2.1	Write.....	20
5.2.2.2	Read	21
5.3	Serial Interface Channel Setup	23
5.3.1	Special Features.....	23
5.3.1.1	Auto RS485 Operation.....	23
5.3.1.2	RS485 Receiver Control	23
5.3.1.3	Slew Rate Limiting	23
5.3.1.4	Low-Power Shutdown.....	23
5.3.2	Channel Setup	24
5.4	RS485/RS422 Configuration Examples.....	25
5.4.1	RS422 Multidrop	25
5.4.2	RS422 Full Duplex Point to Point	25
5.4.3	RS485 Full Duplex Point to Point	25
5.4.4	RS485 Half Duplex Point to Point.....	26
5.4.5	RS485 Full Duplex Multi-point	26
5.4.6	RS485 Half Duplex Multi-point.....	27
5.5	I/O Electrical Interface	28
5.5.1	±15kV ESD Protection	28
5.5.2	RS232 Transceivers	28
5.5.3	RS485/RS422 Transceivers	28
5.5.4	Termination	28
5.6	Block Diagram	29
6	PROGRAMMING HINTS	30
6.1	UART Baud Rate Programming.....	30
7	PIN ASSIGNMENT – I/O CONNECTOR.....	32
7.1	Front Panel I/O Connector	32
7.2	Back I/O XMC Connector (P16).....	33
7.3	Back I/O PMC Connector (P14).....	34

List of Figures

FIGURE 1-1 : BLOCK DIAGRAM.....	6
FIGURE 5-1 : CPLD BUS BLOCK DIAGRAM.....	19
FIGURE 5-2 : CPLD BUS WRITE	20
FIGURE 5-3 : CPLD BUS READ.....	21
FIGURE 5-4 : RS422 MULTIDROP CONFIGURATION	25
FIGURE 5-5 : RS422 FULL DUPLEX POINT TO POINT CONFIGURATION	25
FIGURE 5-6 : RS485 FULL DUPLEX POINT TO POINT CONFIGURATION.....	25
FIGURE 5-7 : RS485 HALF DUPLEX POINT TO POINT CONFIGURATION	26
FIGURE 5-8 : RS485 FULL DUPLEX MULTI-POINT CONFIGURATION.....	26
FIGURE 5-9 : RS485 HALF DUPLEX MULTI-POINT CONFIGURATION	27
FIGURE 5-10: I/O BLOCK DIAGRAM.....	29

List of Tables

TABLE 2-1 : TECHNICAL SPECIFICATION.....	8
TABLE 3-1 : XR17V358 LOCAL SPACE CONFIGURATION.....	9
TABLE 3-2 : DEVICE CONFIGURATION SPACE.....	9
TABLE 3-3 : UART REGISTER SET OFFSET	10
TABLE 3-4 : UART REGISTER SET.....	10
TABLE 3-5 : DEVICE CONFIGURATION REGISTERS	11
TABLE 3-6 : UART CHANNEL CONFIGURATION REGISTERS.....	12
TABLE 4-1 : PCI HEADER.....	14
TABLE 4-2 : CONFIGURATION EEPROM TXMC465.....	15
TABLE 4-3 : PHYSICAL CONFIGURATION EEPROM DATA	17
TABLE 5-1 : CPLD REGISTER ADDRESS MAP.....	18
TABLE 5-2 : CHANNEL CONTROL REGISTER.....	19
TABLE 5-3 : MPIO PINS	19
TABLE 5-4 : MPIO DEVICE CONFIGURATION REGISTERS	20
TABLE 5-5 : SERIAL CHANNEL SETUP.....	24
TABLE 6-1 : UART BAUD RATE PROGRAMMING	30
TABLE 7-1 : PIN ASSIGNMENT FRONT PANEL I/O CONNECTOR.....	32
TABLE 7-2 : PIN ASSIGNMENT P16 BACK I/O CONNECTOR.....	33
TABLE 7-3 : PIN ASSIGNMENT P14 BACK I/O CONNECTOR.....	34

1 Product Description

The TXMC465 is a standard Switched Mezzanine Card (XMC) compatible module offering 8 channels of high performance RS232/RS422/RS485 programmable asynchronous serial interface. The module offers front panel I/O with a HD50 SCSI-2 type connector. The TXMC465-20R offers additional P16 I/O, the TXMC465-30R offers additional P14 I/O.

The serial channels can be individually programmed to operate as RS232, RS422 or RS485 full duplex/half duplex interface. In addition programmable termination is provided for the RS422/RS485 interfaces. After power-up all serial I/O lines are in a high impedance state.

Each RS232 channel supports Rx, Tx, RTS, CTS and GND. RS422 and RS485 full duplex supports a four wire interface (RX+, RX-, TX+, TX-) plus ground (GND). RS485 half duplex supports a two wire interface (DX+, DX-) plus ground (GND).

Each channel has 256 byte transmit and receive FIFOs to significantly reduce the overhead required to provide data to and get data from the transmitters and receivers. The FIFO trigger levels are programmable and the baud rate is individually programmable up to 1 Mbps for RS232 channels and 10 Mbps for RS422/RS485 channels. The UART offers readable FIFO levels.

All serial channels use ESD protected transceivers. ESD protection is up to $\pm 15\text{KV}$.

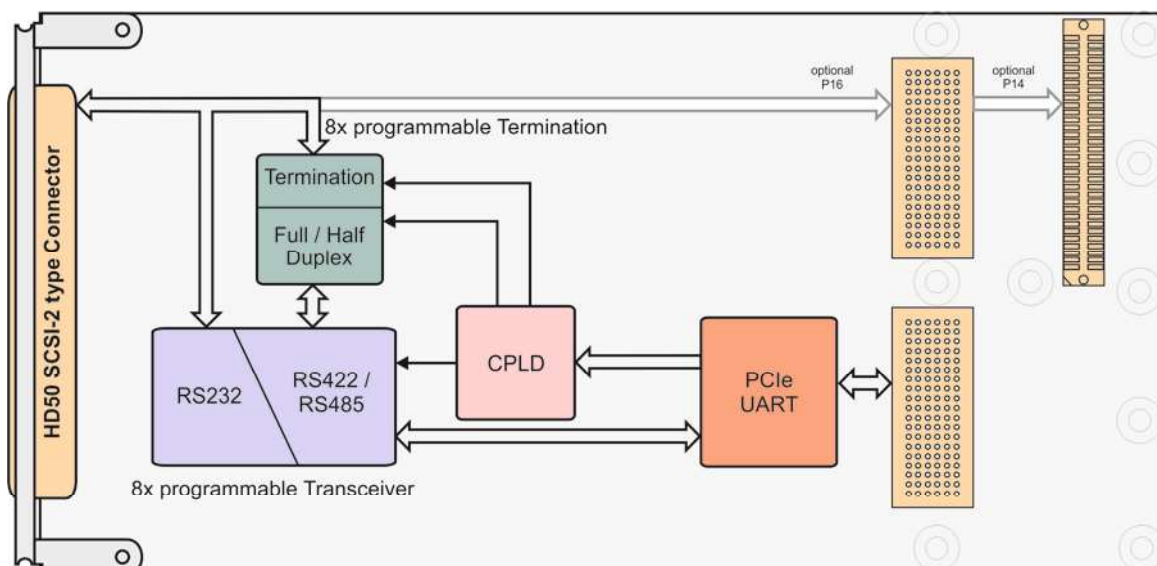

Figure 1-1 : Block Diagram

2 Technical Specification

XMC Interface			
Mechanical Interface	Switched Mezzanine Card (XMC) Interface conforming to ANSI/VITA 42.0-2008 and ANSI/VITA 20-2001 (R2005) Standard single-width (149mm x 74mm)		
Electrical Interface	x1 PCI Express (Base Specification 2.0 Gen 1) compliant interface conforming to ANSI/VITA 42.3-2006 (XMC PCI Express Protocol Layer Standard)		
On Board Devices			
PCIe Target Chip	XR17V358 (Exar)		
Transceiver	MAX3161E		
IPMI Support	per serial EEPROM, as defined in ANSI/VITA 42.0-2008		
I/O Interface			
Interface Type	Asynchronous serial interface		
Number of Channels	8		
Physical Interface	Software selectable RS232, RS422, RS485 full duplex, RS485 half duplex		
Serial Channel I/O Signals	RS232: TxD, RxD, RTS, CTS, GND RS422/RS485 Full Duplex: TxD+/-, RxD+/-, GND RS485 Half Duplex: Dx+/-, GND		
Termination	Software selectable 120Ω		
Programmable Baud Rates	RS232: up to 1 Mbps RS422: up to 10 Mbps		
ESD Protection	±15kV - Human Body Model		
I/O Connector	HD50 SCSI-2 type connector (e.g. AMP# 787395-5) TXMC465-20R: XMC P16 I/O (114 pin Mezzanine Connector) TXMC465-30R: PMC P14 I/O (64 pin Mezzanine Connector)		
Physical Data			
Power Requirements	VPWR is not used +3.3V DC:		
	Mode	No load	Loopback
	Transceiver Shutdown	70 mA	-
	RS232	80 mA	130 mA
	RS422	150 mA	330 mA
	RS485 Full Duplex Master	400 mA	510 mA
	RS485 Half Duplex	150 mA	390 mA
	Loopback: Ch 0 connected to CH 1, CH 2 connected to Ch 3, ...		
Temperature Range	Operating	-40 °C to +85 °C	
	Storage	-40 °C to +85 °C	

MTBF	1 355 000 h MTBF values shown are based on calculation according to MIL-HDBK-217F and MIL-HDBK-217F Notice 2; Environment: G _B 20°C. The MTBF calculation is based on component FIT rates provided by the component suppliers. If FIT rates are not available, MIL-HDBK-217F and MIL-HDBK-217F Notice 2 formulas are used for FIT rate calculation.
Humidity	5 – 95 % non-condensing
Weight	62 g

Table 2-1 : Technical Specification

2.1 Compatibility Identification Block

The ANSI/VITA 42.0 specification demands that a compatibility identification block is published, which identifies supported protocols for each implemented XMC connector.

Standard XMC.3		
P15		
PCIe		
Standard		
1 Lane	Link 0	2.5Gb/s

3 Local Space Addressing

3.1 XR17V358 Local Space Configuration

The local on board addressable regions are accessed from the PCI side by using the XR17V358 local space.

XR17V358 PCI Base Address (Offset in PCI Configuration Space)	PCI Space Mapping	Size (Byte)	Port Width (Bit)	Endian Mode	Description
0 (0x10)	MEM	16k	32	BIG	Device Configuration Space

Table 3-1 : XR17V358 Local Space Configuration

3.2 Device Configuration Space

PCI Base Address: XR17V358 PCI Base Address 0 (Offset 0x10 in PCI Configuration Space).

The TXMC465 uses the Exar XR17V358 Octal UART to provide and control the 8 channels.

Device Configuration Space Content	PCI Address	Size (Bit)
UART 0 Register Set	PCI Base Address 0 + (0x0000 to 0x03FF)	32
UART 1 Register Set	PCI Base Address 0 + (0x0400 to 0x07FF)	32
UART 2 Register Set	PCI Base Address 0 + (0x0800 to 0x0BFF)	32
UART 3 Register Set	PCI Base Address 0 + (0x0C00 to 0x0FFF)	32
UART 4 Register Set	PCI Base Address 0 + (0x1000 to 0x13FF)	32
UART 5 Register Set	PCI Base Address 0 + (0x1400 to 0x17FF)	32
UART 6 Register Set	PCI Base Address 0 + (0x1800 to 0x1BFF)	32
UART 7 Register Set	PCI Base Address 0 + (0x1C00 to 0x1FFF)	32

Table 3-2 : Device Configuration Space

All registers can be accessed in 8, 16, 24 or 32 bit width with exception to one special case: When reading the receive data together with its LSR register content, the host must read them in 16 or 32 bits format in order to maintain integrity of the data byte with its associated error flags.

3.2.1 UART Register Sets

The Device Configuration Space provides a register set for each of the 4 UARTs.

UART Register Set	Register Set Offset
Serial Channel 0	0x0000
Serial Channel 1	0x0400
Serial Channel 2	0x0800
Serial Channel 3	0x0C00
Serial Channel 4	0x1000
Serial Channel 5	0x1400
Serial Channel 6	0x1800
Serial Channel 7	0x1C00

Table 3-3 : UART Register Set Offset

Offset Address	Description	Access	Data Width
0x0000 – 0x000F	UART Channel Configuration Registers First 8 registers are 16550 compatible	R/W	8, 16, 24, 32
0x0010 – 0x007F	Reserved	-	-
0x0080 – 0x009A	Device Configuration Registers	R/W	8, 16, 24, 32
0x009B – 0x00FF	Reserved	-	-
0x0100 – 0x01FF	Read FIFO – 256 bytes of RX FIFO data	R	8, 16, 24, 32
	Write FIFO – 256 bytes of TX FIFO data	W	8, 16, 24, 32
0x0200 – 0x03FF	Read FIFO with errors – 256 bytes of RX FIFO data + LSR	R	16, 32

Table 3-4 : UART Register Set

3.2.2 Device Configuration Registers

The Device Configuration Registers control general operating conditions and monitor the status of various functions. This includes a 16 bit general purpose counter, multipurpose input/outputs (not supported by the TXMC465), sleep mode, soft-reset and device identification, and revision. They are embedded inside the UART register sets. Some registers are accessible from the Device Configuration Registers in all UART register sets, but control only the bit for that channel.

Address	Register	Description	Access	Reset Value
0x080	INT0 [7:0]	Channel Interrupt Indicator	R	0x00
0x081	INT1 [15:8]	Interrupt Source Details	R	0x00
0x082	INT2 [23:16]		R	0x00
0x083	INT3 [31:24]		R	0x00
0x084	TIMERCNTL	Timer Control Register	R/W	0x00
0x085	REGA	Reserved	-	0x00
0x086	TIMERLSB	Programmable Timer Value	R/W	0x00
0x087	TIMERMSB		R/W	0x00
0x088	8XMODE	8X Sampling Rate Enable	R/W	0x00
0x089	4XMODE	4X Sampling Rate Enable	R/W	0x00
0x08A	RESET	UART Reset	W	0x00
0x08B	SLEEP	UART Sleep Mode Enable	R/W	0x00
0x08C	DREV	Device Revision	R	Rev.
0x08D	DVID	Device Identification	R	0x88
0x08E	REGB	Simultaneous UART Write & EEPROM Interface	R/W	0x00
0x08F	MPIOINT	MPIO[7:0] Interrupt Mask	R/W	0x00
0x090	MPIOLVL	MPIO[7:0] Level Control	R/W	0x00
0x091	MPIO3T	MPIO[7:0] Output Pin Tri-state Control	R/W	0x00
0x092	MPIOINV	MPIO[7:0] Input Polarity Select	R/W	0x00
0x093	MPIOSEL	MPIO[7:0] Input/Output Select	R/W	0xFF
0x094	MPIOOD	MPIO[7:0] Open Drain Output Control	R/W	0x00
0x095	MPIOINT	MPIO[15:8] Interrupt Mask	R/W	0x00
0x096	MPIOLVL	MPIO[15:8] Level Control	R/W	0x00
0x097	MPIO3T	MPIO[15:8] Output Pin Tri-state Control	R/W	0x00
0x098	MPIOINV	MPIO[15:8] Input Polarity Select	R/W	0x00
0x099	MPIOSEL	MPIO[15:8] Input/Output Select	R/W	0xFF
0x09A	MPIOD	MPIO[15:8] Open Drain Output Control	R/W	0x00
0x09B	Reserved		-	0x00

Table 3-5 : Device Configuration Registers

For a detailed description of the Device Configuration Registers please refer to the XR17V358 data sheet which is available on the Exar website (www.exar.com).

3.2.3 UART Channel Configuration Registers

Each UART channel has its own set of internal UART configuration registers for its own operation control and status reporting. The following table provides the register offsets within a register set, access types and access control:

Register Offset	Comment	Register	Access	Reset Value
16550 Compatible				
0x00	LCR[7] = 0	RHR – Receive Holding Register	R	0xXX
		THR – Transmit Holding Register	W	
	LCR[7] = 1	DLL – Baud Rate Generator Divisor Latch Low	R/W	0xXX
0x01	LCR[7] = 0	IER – Interrupt Enable Register	R/W	0x00
		LCR[7] = 1	DLM – Baud Rate Generator Divisor Latch High	
0x02	LCR[7] = 0	ISR – Interrupt Status Register	R	0x01
		FCR – FIFO Control Register	W	0x00
	LCR[7] = 1	DLD – Divisor Fractional	R/W	0xXX
0x03		LCR – Line Control Register	R/W	0x00
0x04		MCR – Modem Control Register	R/W	0x00
0x05		LSR – Line Status Register	R	0x60
		Reserved	W	
0x06		MSR – Modem Status Register	R	0xX0
		– Auto RS485 Delay (not supported by the TXMC465)	W	
0x07	User Data	SPR – Scratch Pad Register	R/W	0xFF
Enhanced Registers				
0x08		FCTR – Feature Control Register	R/W	0x00
0x09		EFR – Enhanced Function Register	R/W	0x00
0x0A		TXCNT – Transmit FIFO Level Counter	R	0x00
		TXTRG – Transmit FIFO Trigger Level	W	
0x0B		RXCNT – Receiver FIFO Level Counter	R	0x00
		RXTRG – Receiver FIFO Trigger Level	W	
0x0C		Xchar – Xon, Xoff Received Flags	R	0x00
		Xoff-1 – Xoff Character 1	W	
0x0D		Reserved	R	0x00
		Xoff-2 – Xoff Character 2	W	
0x0E		Reserved	R	0x00
		Xon-1 – Xon Character 1	W	
0x0F		Reserved	R	0x00
		Xon-2 – Xon Character 2	W	

Table 3-6 : UART Channel Configuration Registers

The address for a UART Channel Configuration Register *x* in a UART Register Set for channel *y* is:

PCI Base Address 0 (PCI Base Address for the UART Register Space)

+ UART Register Set Offset for *channel y*

+ Register Offset for *register x*

Addressing example:

The address for the LCR register of UART channel 2 is:

PCI Base Address (PCI Base Address for the Device Configuration Space)

+ 0x0800 (Offset of the UART register set for serial channel 2)

+ 0x0003 (Offset of the LCR register within a UART register set)

For a detailed description of the serial channel registers please refer to the XR17V358 data sheet which is available on the Exar website (www.exar.com).

4 XR17V358 Target Chip

4.1 PCI Configuration Registers (PCR)

PCI CFG Register Address	Write '0' to all unused (Reserved) bits							PCI writeable	Initial Values (Hex Values)	
	31	24	23	16	15	8	7			0
0x00	Device ID				Vendor ID				N	91D1 1498
0x04	Status				Command				Y	0080 0000
0x08	Class Code					Revision ID			N	070002 ??
0x0C	BIST	Header Type		PCI Latency Timer		Cache Line Size		N	00 00 00 00	
0x10	Memory Base Address Register (BAR0)							Y	FFFC000	
0x14	Base Address Register (Unimplemented)							N	00000000	
0x18	Base Address Register (Unimplemented)							N	00000000	
0x1C	Base Address Register (Unimplemented)							N	00000000	
0x20	Base Address Register (Unimplemented)							N	00000000	
0x24	Base Address Register (Unimplemented)							N	00000000	
0x28	Reserved							N	00000000	
0x2C	Subsystem ID			Subsystem Vendor ID				N	s.b. 1498	
0x30	Expansion ROM Base Address (Unimplemented)							N	00000000	
0x34	Reserved							N	00000000	
0x38	Reserved							N	00000000	
0x3C	Max_Lat	Min_Gnt		Interrupt Pin		Interrupt Line		Y[7:0]	00 00 01 00	

Table 4-1 : PCI Header

Device-ID: 0x91D1 TXMC465
 Vendor-ID: 0x1498 TEWS TECHNOLOGIES
 Revision ID: XR17V358 silicon revision
 Subsystem-ID: 0x900A -10R
 0x9014 -20R
 0x901E -30R
 Subsystem Vendor-ID: 0x1498 TEWS TECHNOLOGIES

4.2 Configuration EEPROM

After power-on or PCI reset, the XR17V358 loads initial configuration register data from the on board configuration EEPROM.

The configuration EEPROM contains the following configuration data:

- Vendor ID
- Vendor Device ID
- Subsystem Vendor-ID
- Subsystem ID

See the XR17V358 Manual for more information.

Address	Configuration Register	Value
0x00	Address Word	0x0000
0x01	Vendor ID	0x1498
0x02	Address Word	0x8001
0x03	Device ID	0x91D1
0x04	Address Word	0x8004
0x05	Subsystem Vendor-ID	0x1498
0x06	Address Word	0x4005
0x07	Subsystem ID	s.b.

Table 4-2 : Configuration EEPROM TXMC465

Subsystem-ID Value (Offset 0x07): TXMC465-10R 0x900A
TXMC465-20R 0x9014
TXMC465-30R 0x901E

The words following the configuration data contain:

- The module version and revision
- The UART clock frequency in Hz
- The physical interface attached to the serial channels
- The maximal baud rate of the transceivers in bps
- The supported control signals of the serial channels

For the physical interfaces and the control signals applies: Bit 7 represents UART channel 7 and bit 0 represents UART channel 0. The appropriate bit is set to '1' for each UART channel attached to the physical interface represented by the word. Bit 15 to bit 8 are always '0'.

Address	Configuration Register	TXMC465
0x08	Module Version	Reflects Module Version (i.e. V1.0)
0x09	Module Revision	Reflects Module Revision (i.e. Rev.A)
0x0A	EEPROM Revision	0x0003
0x0B	Oscillator Frequency (high)	0x0773
0x0C	Oscillator Frequency (low)	0x5940
0x0D	Reserved	-
0x0E	Reserved	-
0x0F	Controller Type	0x0001
0x10	RS232 Channels	0x00FF
0x11	RS422 Channels	0x00FF
0x12	TTL Channels	0x0000
0x13	RS485 Full Duplex Channels	0x00FF
0x14	RS485 Half Duplex Channels	0x00FF
0x15-0x1E	Reserved	-
0x1F	Programmable Interfaces	0x00FF
0x20	Max Data Rate RS232 (high)	0x000F
0x21	Max Data Rate RS232 (low)	0x4240
0x22	Max Data Rate RS422 (high)	0x0098
0x23	Max Data Rate RS422 (low)	0x9680
0x24	Max Data Rate TTL (high)	0x0000
0x25	Max Data Rate TTL (low)	0x0000
0x26	Max Data Rate RS485 Full Duplex (high)	0x0098
0x27	Max Data Rate RS485 Full Duplex (low)	0x9680
0x28	Max Data Rate RS485 Half Duplex (high)	0x0098
0x29	Max Data Rate RS485 Half Duplex (low)	0x9680
0x2A-0x2F	Reserved	-
0x30	RxD & TxD	0x00FF
0x31	RTS & CTS	0x0000
0x32	Full modem	0x0000
0x33-0x37	Reserved	-
0x38	Enhanced RTS & CTS (Front- or Back I/O only)	0x0000
0x39	Enhanced Full modem (Front- or Back I/O only)	0x0000
0x3A	Channels with enhanced RTS & CTS Support for RS232 only	0x00FF
0x3B	Channels with RxD support only	0x0000

Address	Configuration Register	TXMC465
0x3B-0x3F	Reserved	-

Table 4-3 : Physical Configuration EEPROM Data

5 Configuration Hints

The TXMC465 physical interfaces of the serial channels are individually software programmable to various interface configurations. For this purpose a CPLD provides a control register for each interface channel.

5.1 CPLD Description

The CPLD provides a Channel Control Register for each of the interface channels. Each of the Channel Control Registers is individually addressable. The access to this registers is described in detail in chapter “CPLD Access”.

5.1.1 CPLD Address Map

Refer to the following chart for the register addresses.

Address	Register Name	Size (Bit)
000	Control Register Channel 0	7
001	Control Register Channel 1	7
010	Control Register Channel 2	7
011	Control Register Channel 3	7
100	Control Register Channel 4	7
101	Control Register Channel 5	7
110	Control Register Channel 6	7
111	Control Register Channel 7	7

Table 5-1 : CPLD Register Address Map

5.1.2 Channel Control Register

This register is identical for all channels.

Bit	Symbol	Description	Access	Reset Value
6	SHDN	Active-Low Shutdown-Control. Drive SHDN high to shut down transmitters and charge pump. '0': Normal operation '1': Shutdown	R/W	1
5	SLEW LIMIT	Transmitter Speed-Select. Select slew-rate limiting for RS232 and RS485. Slew-rate limits with a logic-level high. '0': Normal data rate limit (RS232: 1 Mbps; RS485: 10 Mbps) '1': Limit data rate to 250 kbps (both RS232 & RS485)	R/W	0
4	TTERM	Transmitter Termination Enable Terminate transmit line with a 120Ω termination resistor '0': Termination inactive '1': Termination active	R/W	0
3	RTERM	Receiver Termination Enable Terminate receive line with a 120Ω termination resistor '0': Termination inactive '1': Termination active	R/W	0

Bit	Symbol	Description	Access	Reset Value
2	RENA	Auto RS485 Receiver Enable When the Auto RTS Control feature of the XR17V358 is used in half duplex configurations, this bit can be used to inhibit the reception of an echo of the own data transmission '0': Normal operation (receiver is always enabled) '1': Inhibit echo reception (receiver is disabled during data transmission)	R/W	0
1	HDPLX	Selectable Mode Functionality. Operates in full-duplex mode when low; operates in half-duplex mode when high. '0': Full-duplex '1': Half-Duplex	R/W	0
0	RS485/ RS232#	Selectable Mode Functionality. Operates as RS485 with a logic-level high; operates as RS232 with a logic-level low. '0': RS232 '1': RS485	R/W	0

Table 5-2 : Channel Control Register

5.2 CPLD Access

The CPLD is connected to the MPIO-pins of the XR17V358 to provide access to the control registers.

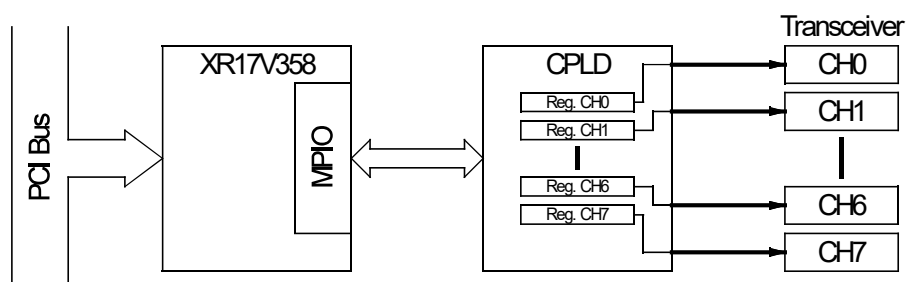

Figure 5-1 : CPLD Bus Block Diagram

The MPIO pins form a simple bus to the CPLD. The following chart gives an overview about the MPIO pin assignment:

MPIO Pin	Direction	Function
MPIO[0]	Output	CEN – Chip Enable
MPIO[1]	Output	R/W# - Read/Write Low: Write to Address High: Read from Address
MPIO[2]	Output	CLK – Clock
MPIO[5-3]	Output	ADR – Register Address
MPIO[6]	Output	DATAOUT – Serial Data Output
MPIO[7]	Input	DATAIN – Serial Data Input

Table 5-3 : MPIO Pins

5.2.1 Accessing XR17V358 MPIO Pins

The MPIO Registers are accessible at PCI Base Address 0 + Device Configuration Register Offset.

Address Offset	Register	Description	Access	Reset Value
0x08F	MPIOINT	MPIO[7:0] Interrupt Mask	R/W	0x00
0x090	MPIOLVL	MPIO[7:0] Level Control	R/W	0x00
0x091	MPIO3T	MPIO[7:0] Output Pin Tri-state Control	R/W	0x00
0x092	MPIOINV	MPIO[7:0] Input Polarity Select	R/W	0x00
0x093	MPIOSEL	MPIO[7:0] Input/Output Select	R/W	0xFF
0x094	MPIOOD	MPIO[7:0] Open Drain Output Control	R/W	0x00
0x095	MPIOINT	MPIO[15:8] Interrupt Mask	R/W	0x00
0x096	MPIOLVL	MPIO[15:8] Level Control	R/W	0x00
0x097	MPIO3T	MPIO[15:8] Output Pin Tri-state Control	R/W	0x00
0x098	MPIOINV	MPIO[15:8] Input Polarity Select	R/W	0x00
0x099	MPIOSEL	MPIO[15:8] Input/Output Select	R/W	0xFF
0x09A	MPIOOD	MPIO[15:8] Open Drain Output Control	R/W	0x00

Table 5-4 : MPIO Device Configuration Registers

MPIOINT, MPIOLVL, MPIO3T and MPIOOD must be left at their default values. MPIOSEL must be set to 0x80 to configure MPIO[6-0] pins as outputs and MPIO[7] as input. MPIOLVL sets the output level of the MPIO output pins and is used to write on the CPLD bus.

5.2.2 CPLD Bus Protocol

5.2.2.1 Write

A CPLD register write access starts with setting CEN to '1'. This resets the CPLD's internal state-machine. Before the first clock pulse is issued, ADR and DATAOUT have to be set; R/W# must be left '0'. The first rising edge of CLK samples the ADR bits and the DATAOUT bit. ADR determines which internal register is accessed. The following 6 rising edges of CLK sample the remaining data bits, additional CLK pulses are ignored. Setting CEN back to '0' completes the access and the configuration of the transceivers will be updated.

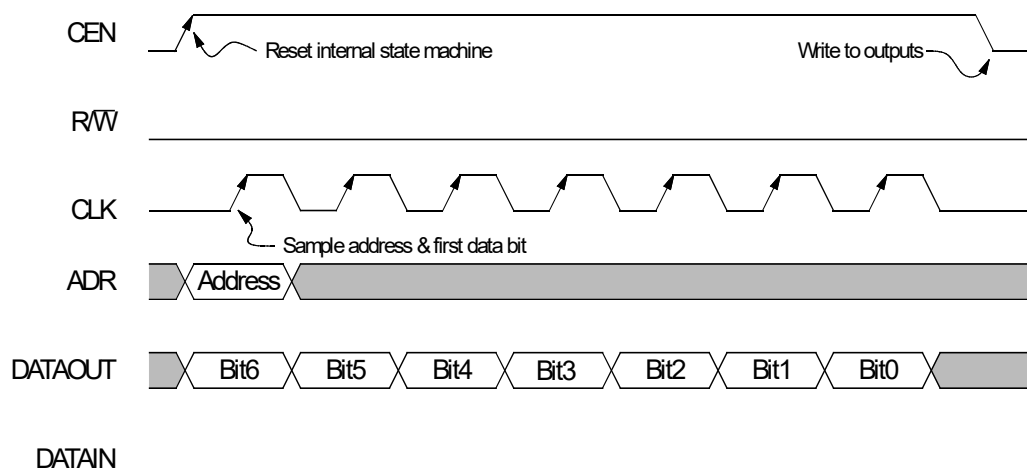

Figure 5-2 : CPLD Bus Write

Example (pseudocode):

Write value 0x05 to CPLD address 0x03

```

define MPIOLVL 0x90;
define MPIOSEL 0x93;
void Write_XR17V358(int address, int value);

Write_XR17V358(MPIOSEL, 0x80);           // Setting up MPIOSEL

Write_XR17V358(MPIOLVL, 0x19);          // CEN = '1', ADR = "011", D(6) = '0'
Write_XR17V358(MPIOLVL, 0x1D);          // CLK = '1'
Write_XR17V358(MPIOLVL, 0x01);          // CLK = '0', ADR = "000", D(5) = '0'
Write_XR17V358(MPIOLVL, 0x05);          // CLK = '1'
Write_XR17V358(MPIOLVL, 0x01);          // CLK = '0', D(4) = '0'
Write_XR17V358(MPIOLVL, 0x05);          // CLK = '1'
Write_XR17V358(MPIOLVL, 0x01);          // CLK = '0', D(3) = '0'
Write_XR17V358(MPIOLVL, 0x05);          // CLK = '1'
Write_XR17V358(MPIOLVL, 0x41);          // CLK = '0', D(2) = '1'
Write_XR17V358(MPIOLVL, 0x45);          // CLK = '1'
Write_XR17V358(MPIOLVL, 0x01);          // CLK = '0', D(1) = '0'
Write_XR17V358(MPIOLVL, 0x05);          // CLK = '1'
Write_XR17V358(MPIOLVL, 0x41);          // CLK = '0', D(0) = '1'
Write_XR17V358(MPIOLVL, 0x45);          // CLK = '1'
Write_XR17V358(MPIOLVL, 0x00);          // CLK = '0', CEN = '0'

```

5.2.2.2 Read

A CPLD register read access starts with setting CEN to '1'. This resets the CPLD's internal state-machine. Before the first clock pulse is issued, ADR and R/W# have to be set. The first rising edge of CLK samples the ADR bits and starts the output of the first DATAIN bit. ADR determines which internal register is accessed. The following 6 rising edges of CLK put out the remaining data bits, additional CLK pulses are ignored. Setting CEN back to '0' completes the access.

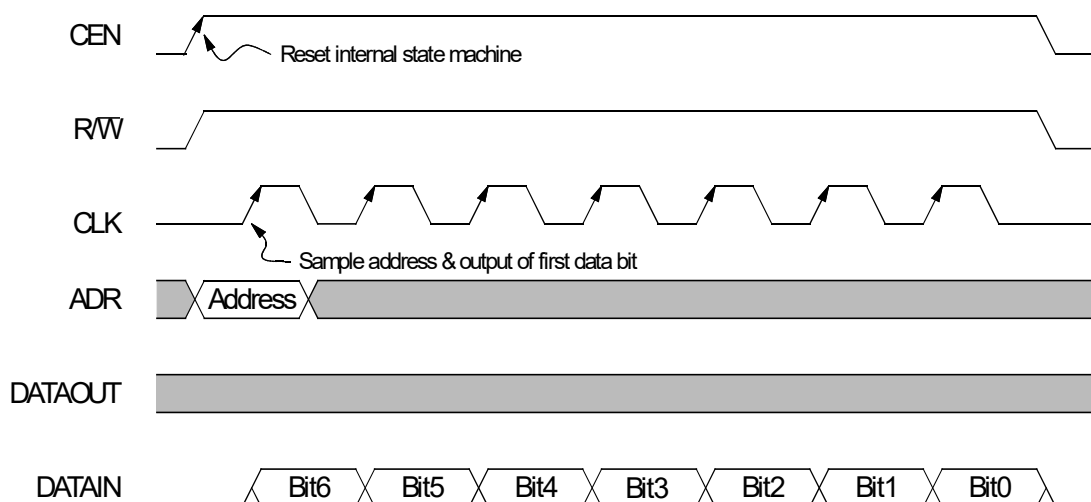

Figure 5-3 : CPLD Bus Read

Example (pseudocode):

Read value 0x05 to CPLD address 0x03

```

define MPIOLVL 0x90;
define MPIOSEL 0x93;
int    Read_XR17V358(int address);           // Returns the address' bit 7
int    value

Write_XR17V358(MPIOSEL, 0x80);              // Setting up MPIOSEL

Write_XR17V358(MPIOLVL, 0x1B);              // CEN = '1', ADR = "011", R/W# = '1'
Write_XR17V358(MPIOLVL, 0x1F);              // CLK = '1'
Write_XR17V358(MPIOLVL, 0x03);              // CLK = '0', ADR = "000"
value |= (Read_XR17V358(MPIOLVL) << 6);    // Read D(6)
Write_XR17V358(MPIOLVL, 0x07);              // CLK = '1'
Write_XR17V358(MPIOLVL, 0x03);              // CLK = '0'
value |= (Read_XR17V358(MPIOLVL) << 5);    // Read D(5)
Write_XR17V358(MPIOLVL, 0x07);              // CLK = '1'
Write_XR17V358(MPIOLVL, 0x03);              // CLK = '0'
value |= (Read_XR17V358(MPIOLVL) << 4);    // Read D(4)
Write_XR17V358(MPIOLVL, 0x07);              // CLK = '1'
Write_XR17V358(MPIOLVL, 0x03);              // CLK = '0'
value |= (Read_XR17V358(MPIOLVL) << 3);    // Read D(3)
Write_XR17V358(MPIOLVL, 0x07);              // CLK = '1'
Write_XR17V358(MPIOLVL, 0x03);              // CLK = '0'
value |= (Read_XR17V358(MPIOLVL) << 2);    // Read D(2)
Write_XR17V358(MPIOLVL, 0x07);              // CLK = '1'
Write_XR17V358(MPIOLVL, 0x03);              // CLK = '0'
value |= (Read_XR17V358(MPIOLVL) << 1);    // Read D(1)
Write_XR17V358(MPIOLVL, 0x07);              // CLK = '1'
Write_XR17V358(MPIOLVL, 0x03);              // CLK = '0'
value |= (Read_XR17V358(MPIOLVL) << 0);    // Read D(0)
Write_XR17V358(MPIOLVL, 0x00);              // CEN = '0', R/W# = '0'

```

5.3 Serial Interface Channel Setup

After power-up all transceivers are in shutdown mode, i.e. the outputs are in tri-state mode. Therefore the serial interfaces must be properly set up before they can be used.

The interfaces can be programmed to following modes:

- RS232
- RS485/RS422 full-duplex (with optional termination)
- RS485 half-duplex (Master/Slave, with optional termination)

5.3.1 Special Features

5.3.1.1 Auto RS485 Operation

In RS485 half duplex applications it is necessary to tristate the driver when it is not active. The XR17V358 provides a special function, the “Auto RS485 Operation” for this purpose. The UART’s RTS signal is connected to the driver enable pin of the transceiver. The UART asserts RTS to enable the driver before it starts to send a character and deasserts the RTS signal after a programmable delay after the stop bit of the last transmitted character. The delay optimizes the time needed for the last transmission to reach the farthest station on a long cable network before switching off the line driver.

The Auto RS485 Operation is enabled by FCTR bit 5. The delay is specified in MSR[7:4]

5.3.1.2 RS485 Receiver Control

In RS485 half duplex applications the driver and receiver are connected with each other. To prevent the echo of local data, the receive line can be inhibited for the time the driver is enabled. This is done by activating the “Auto RS485 Receiver Enable” in the Channel Control Register.

When the Auto RS485 Receiver Enable is not activated in a half duplex application, this will result in a kind of loopback mode. This may be done on purpose to monitor the loopback data for errors which would indicate a line contention. When the channel is unconnected, this may also be used as a build in self test.

5.3.1.3 Slew Rate Limiting

The SLEW LIMIT control is used to select the slew-rate limiting of the RS232 transmitters and the RS485/RS422 drivers. With SLEW LIMIT asserted, the RS232 transmitters and the RS485/RS422 driver are slew-rate limited to reduce EMI, resulting in a max data rate of 250kbps. RS232 data rates up to 1Mbps and RS485/RS422 data rates up to 10Mbps are possible when SLEW LIMIT is unasserted. SLEW LIMIT can be changed during operation without interrupting data communications.

5.3.1.4 Low-Power Shutdown

The MAX3161E has a shutdown control input, SHDN. When SHDN is ON, the charge pump and transmitters are shut down and supply current is reduced to 10nA. The RS232 receiver outputs remain active if in RS232 mode. The charge-pump capacitors must be recharged when coming out of shutdown before resuming operation in either RS232 or RS485/RS422 mode.

5.3.2 Channel Setup

Each interface channel must be set up in its associated Channel Control Register in the CPLD. Depending on the interface configuration the “Auto RS485 Operation” must be activated in the Feature Control Register in the XR17V358. Refer to the next chapter “RS485/RS422 Configuration Examples” to find out which interface configurations suits your needs.

The following table shows how to program the interfaces to the commonly used modes:

Bit	Symbol	Reset Value	RS232	RS422 Multidrop	RS422 FD	RS485 FD (Master)	RS485 FD Slave	RS485 HD
	CPLD	Channel Control Register						
0	RS485/RS232#	OFF	OFF	ON	ON	ON	ON	ON
1	HDPLX	OFF	OFF	OFF	OFF	OFF	OFF	ON
2	RENA	OFF	OFF	OFF	OFF	OFF	OFF	ON
3	RTERM	OFF	OFF (1)	ON (2)	ON	ON	ON (2)	OFF
4	TTERM	OFF	OFF (1)	OFF	OFF	ON	ON (2)	ON (2)
5	SLEW LIMIT	OFF	User	User	User	User	User	User
6	SHDN	ON	OFF	OFF	OFF	OFF	OFF	OFF
	XR17V358	Feature Control Register (FCTR)						
5	Auto RS485 Operation	OFF	OFF	OFF	OFF	OFF	ON	ON

(1) RTERM / TTERM settings are ignored in RS232 mode.

(2) Depends on bus configuration. Terminate only if the transceiver is the end-point of the bus.

Table 5-5 : Serial Channel Setup

5.4 RS485/RS422 Configuration Examples

5.4.1 RS422 Multidrop

RS485	HDPLX	RENA	RTERM	TTERM	FCTR[5]
ON	OFF	OFF	ON*	OFF	OFF

* Terminate only if the device is a receiver and the end-point of the bus.

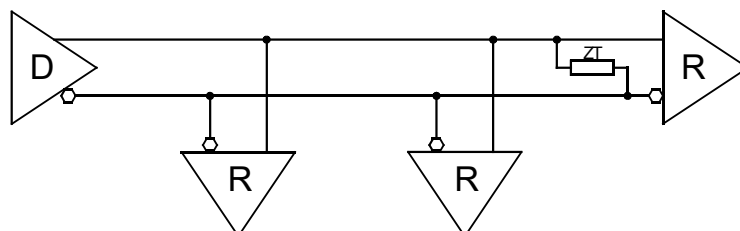

Figure 5-4 : RS422 Multidrop Configuration

5.4.2 RS422 Full Duplex Point to Point

RS485	HDPLX	RENA	RTERM	TTERM	FCTR[5]
ON	OFF	OFF	ON	OFF	OFF

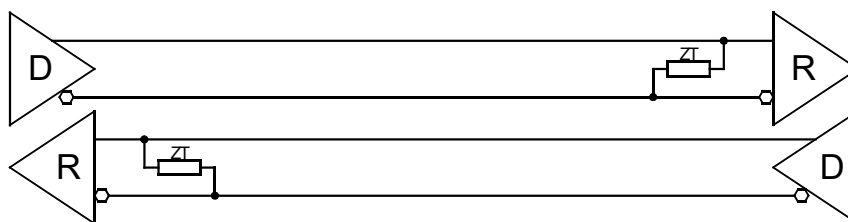

Figure 5-5 : RS422 Full Duplex Point to Point Configuration

5.4.3 RS485 Full Duplex Point to Point

RS485	HDPLX	RENA	RTERM	TTERM	FCTR[5]
ON	OFF	OFF	ON	ON	OFF

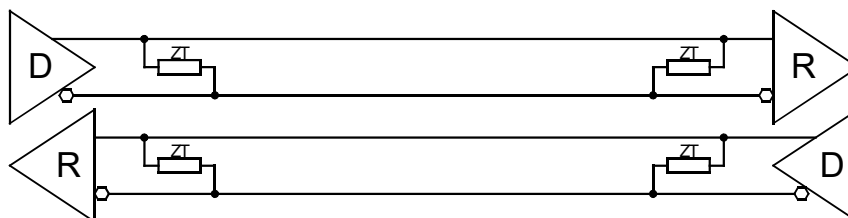

Figure 5-6 : RS485 Full Duplex Point to Point Configuration

5.4.4 RS485 Half Duplex Point to Point

RS485	HDPLX	RENA	RTERM	TTERM	FCTR[5]
ON	ON	ON	OFF	ON	ON

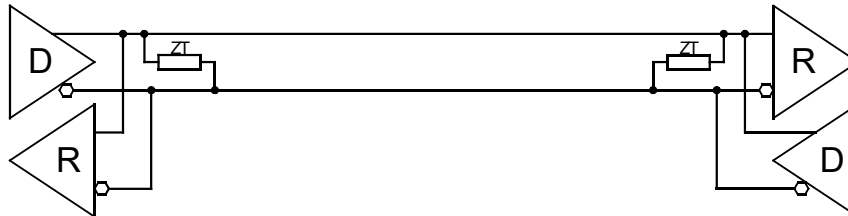

Figure 5-7 : RS485 Half Duplex Point to Point Configuration

5.4.5 RS485 Full Duplex Multi-point

Also referred to as “party-line”

Master

RS485	HDPLX	RENA	RTERM	TTERM	FCTR[5]
ON	OFF	OFF	ON	ON	OFF

Slave

RS485	HDPLX	RENA	RTERM	TTERM	FCTR[5]
ON	OFF	OFF	ON*	ON*	ON

* Terminate only if the device is the end-point of the bus.

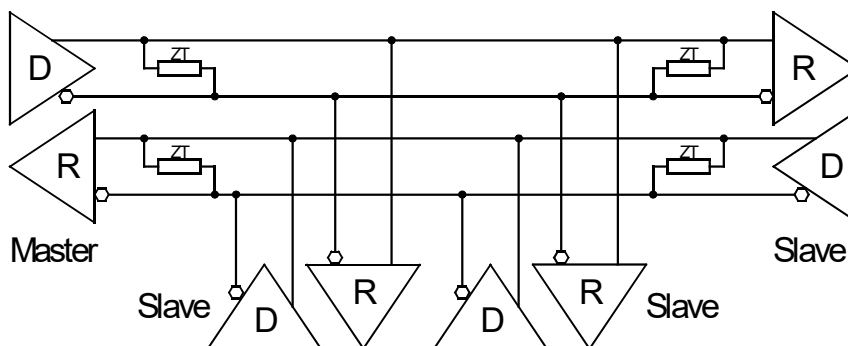

Figure 5-8 : RS485 Full Duplex Multi-Point Configuration

5.4.6 RS485 Half Duplex Multi-point

Also referred to as “party-line”

RS485	HDPLX	RENA	RTERM	TTERM	FCTR[5]
ON	ON	ON	OFF	ON*	ON

* Terminate only if the device is the end-point of the bus.

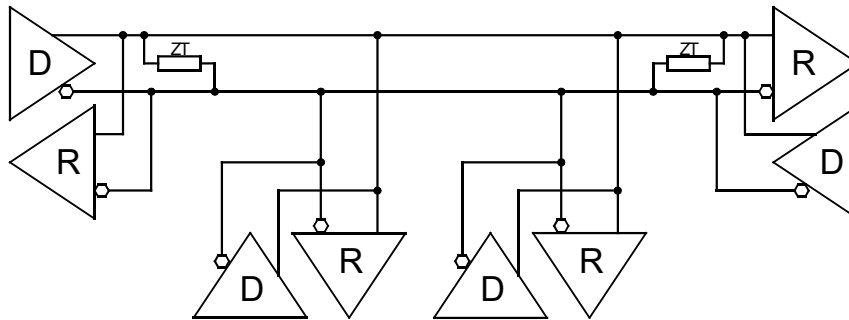

Figure 5-9 : RS485 Half Duplex Multi-Point Configuration

5.5 I/O Electrical Interface

5.5.1 $\pm 15\text{kV}$ ESD Protection

The receiver inputs and transmitter outputs are characterized for $\pm 15\text{kV}$ ESD protection using the Human Body Model.

5.5.2 RS232 Transceivers

The RS232 transmitters are inverting-level translators that convert CMOS-logic levels to $\pm 5\text{V}$ EIA/TIA-232-compliant levels. The transmitters are guaranteed at a 250kbps data rate in slew-rate limited mode with worst-case loads of $3\text{k}\Omega$ in parallel with 1000pF . Data rates up to 1Mbps can be achieved by not asserting SLEW LIMIT. When powered down or in shutdown, the outputs are high impedance and can be driven to $\pm 13.2\text{V}$.

The receivers convert RS232 signals to CMOS-logic output levels. All receivers have inverting outputs that remain active in shutdown. The MAX3161E permit their receiver inputs to be driven to $\pm 25\text{V}$. Floating receiver input signals are pulled to ground through internal $5\text{k}\Omega$ resistors, forcing the outputs to a logic-high.

5.5.3 RS485/RS422 Transceivers

The RS485/RS422 transceivers feature fail-safe circuitry that guarantees a logic-high receiver output when the receiver inputs are open or shorted, or when they are connected to a terminated transmission line with all drivers disabled. They also feature selectable reduced slew-rate drivers that minimize EMI and reduce reflections caused by improperly terminated cables, allowing error-free data transmission up to 250kbps. The transmitters can operate at speeds up to 10Mbps with the slew-rate limiting disabled. Drivers are short-circuit current limited and thermally limited to protect them against excessive power dissipation. Half-duplex communication is enabled by driving HDPLX high.

5.5.4 Termination

The receive and the transmit line can be terminated with a 120Ω termination resistor. The termination is software selectable.

5.6 Block Diagram

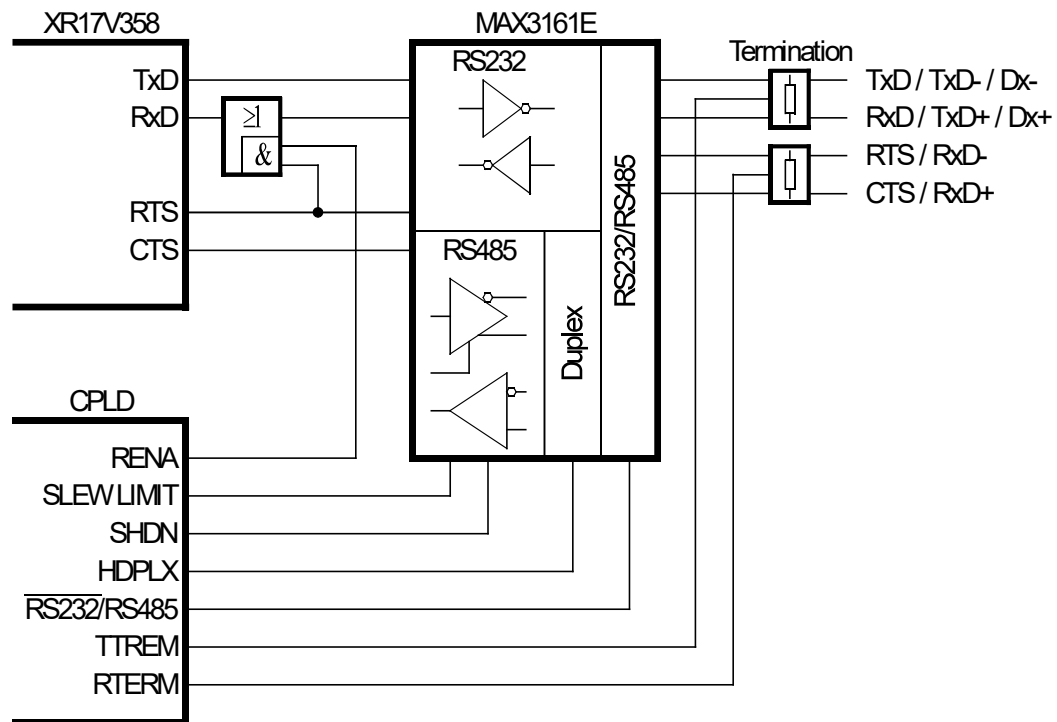

Figure 5-10: I/O Block Diagram

6 Programming Hints

6.1 UART Baud Rate Programming

Each of the 8 UART channels of the TXMC465 provides a programmable Baud Rate Generator. The clock of the XR17V358 UART can be divided by any divisor from 1 to $2^{16} - 0.0625$. The divisor can be programmed by the UART channel DLM (Divisor MSB), DLL (Divisor LSB) and DLD (Divisor Fractional) registers. After a reset bit 7 of the UART channels MCR register defaults to '0' and the divisor value is 0xFFFF.

The sampling rate for a UART channel can be set to 8x (normal operation is 16x) in the 8XMODE register or 4x in the 4XMODE register. Transmit and receive data rates will double by selecting 8x sample rate or quadruple by selecting the 4x sample rate.

The basic formula of baud rate programming is:

$$\text{Baud Rate} = \frac{125\text{MHz}}{\text{MODE} \cdot \text{Divisor} \cdot (1 + 3 \cdot \text{MCR}[7])}$$

where MODE is 16 for 16XMODE, 8 for 8XMODE and 4 for 4XMODE.

Examples for standard baud rates are given in following chart (using 16XMODE sampling):

Baud Rate MCR[7] = 0	Baud Rate MCR[7] = 1	Divisor	DLM Value	DLL Value	DLD Value	Error (%)
9600	2400	813 12/16	0x03	0x2D	0xC	0.01
19.2k	4800	406 14/16	0x01	0x96	0xE	0.01
115.2k	28.8k	67 13/16	0x00	0x43	0xD	0.01
230.4k	57.6k	33 14/16	0x00	0x21	0xE	0.10
460.8k	115.2k	16 15/16	0x00	0x10	0xF	0.10
500k	125k	15 10/16	0x00	0x0F	0xA	0
750k	187.5	10 6/16	0x00	0x0A	0x6	0.40
921.6k	230.4k	8 7/16	0x00	0x08	0x7	0.47
1000k	250k	7 13/16	0x00	0x07	0xD	0
1250k	312.5k	6 4/16	0x00	0x06	0x4	0
1500k	375k	5 3/16	0x00	0x05	0x3	0.40

Table 6-1 : UART Baud Rate Programming

The achievable baud rate will not always exactly match the desired baud rate (see the "Error" column in the table above). A small error (up to 1%) will not affect the UART function.

To calculate a divisor value for a given baud rate, use following formula:

$$\text{Divisor} = \frac{125\text{MHz}}{\text{MODE} \cdot \text{Baud Rate} \cdot (1 + 3 \cdot \text{MCR}[7])}$$

where MODE is 16 for 16XMODE, 8 for 8XMODE and 4 for 4XMODE.

These steps should be used to modify the DLM, DLL and DLD registers of an UART channel:

1. Write 0x80 to the LCR register of the UART channel (enable access to the DLM, DLL and DLD registers).
2. Program the DLM, DLL and DLD registers of the UART channel.
3. Write normal operation byte value to the LCR register of the UART channel.

These steps should be used to modify MCR register bit 7 of an UART channel (set baud rate generator prescaler):

1. Set UART channel EFR register bit 4 to '1' (enable modification of MCR register bits 5-7).
2. Modify UART channel MCR register bit 7.
3. Set UART channel EFR register bit 4 to '0' (latch modified MCR register setting).

Note that the maximum baud rate for RS232 channel is 1 Mbps. Thus the minimum divisor value for RS232 channels is 0x0007D with MCR[7] = 0 and 16XMODE sampling.

7 Pin Assignment – I/O Connector

7.1 Front Panel I/O Connector

Connector Type		HD50 SCSI-2 female				
Source & Order Info		AMP# 787395-5				
Pin Assignment						
Description		Pin	Connector View	Pin	Description	
RS232	RS422 RS485				RS232	RS422 RS485
GND		1		26	GND	
TxD0	TxD0-/Dx0-	2		27	TxD5	TxD5-/Dx5-
RxD0	TxD0+/Dx0+	3		28	RxD5	TxD5+/Dx5+
RTS0	RxD0-	4		29	RTS5	RxD5-
CTS0	RxD0+	5		30	CTS5	RxD5+
GND		6		31	GND	
TxD1	TxD1-/Dx1-	7		32	TxD6	TxD6-/Dx6-
RxD1	TxD1+/Dx1+	8		33	RxD6	TxD6+/Dx6+
RTS1	RxD1-	9		34	RTS6	RxD6-
CTS1	RxD1+	10		35	CTS6	RxD6+
GND		11		36	GND	
TxD2	TxD2-/Dx2-	12		37	TxD7	TxD7-/Dx7-
RxD2	TxD2+/Dx2+	13		38	RxD7	TxD7+/Dx7+
RTS2	RxD2-	14		39	RTS7	RxD7-
CTS2	RxD2+	15		40	CTS7	RxD7+
GND		16		41	GND	
TxD3	TxD3-/Dx3-	17		42	-	-
RxD3	TxD3+/Dx3+	18		43	-	-
RTS3	RxD3-	19		44	-	-
CTS3	RxD3+	20		45	-	-
GND		21		46	-	-
TxD4	TxD4-/Dx4-	22		47	-	-
RxD4	TxD4+/Dx4+	23		48	-	-
RTS4	RxD4-	24		49	-	-
CTS4	RxD4+	25		50	-	-

Table 7-1 : Pin Assignment Front Panel I/O Connector

7.2 Back I/O XMC Connector (P16)

This pinout is compatible with carriers that implement a VITA 46.9 X8d + X12d or X12d + X8d style pin mapping.

	A	B	C	D	E	F
1	RxD0 / TxD0+	TxD0 / TxD0-	-	CTS0 / RxD0+	RTS0 / RxD0-	-
2	GND	GND	-	GND	GND	-
3	RxD1 / TxD1+	TxD1 / TxD1-	-	CTS1 / RxD1+	RTS1 / RxD1-	-
4	GND	GND	-	GND	GND	-
5	RxD4 / TxD4+	TxD4 / TxD4-	-	CTS4 / RxD4+	RTS4 / RxD4-	-
6	GND	GND	-	GND	GND	-
7	RxD5 / TxD5+	TxD5 / TxD5-	-	CTS5 / RxD5+	RTS5 / RxD5-	-
8	GND	GND	-	GND	GND	-
9	-	-	-	-	-	-
10	GND	GND	-	GND	GND	-
11	RxD2 / TxD2+	TxD2 / TxD2-	-	CTS2 / RxD2+	RTS2 / RxD2-	-
12	GND	GND	-	GND	GND	-
13	RxD3 / TxD3+	TxD3 / TxD3-	-	CTS3 / RxD3+	RTS3 / RxD3-	-
14	GND	GND	-	GND	GND	-
15	RxD6 / TxD6+	TxD6 / TxD6-	-	CTS6 / RxD6+	RTS6 / RxD6-	-
16	GND	GND	-	GND	GND	-
17	RxD7 / TxD7+	TxD7 / TxD7-	-	CTS7 / RxD7+	RTS7 / RxD7-	-
18	GND	GND	-	GND	GND	-
19	-	-	-	-	-	-

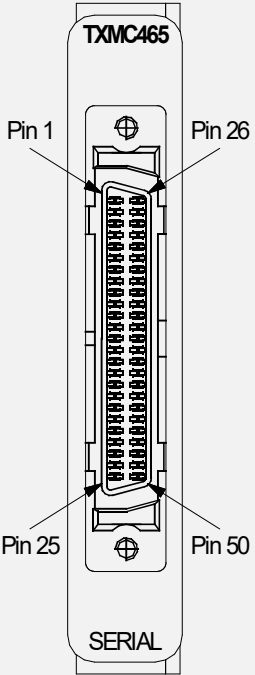
Table 7-2 : Pin Assignment P16 Back I/O Connector

7.3 Back I/O PMC Connector (P14)

Pin Assignment						
Description		Pin		Pin	Description	
RS232	RS422/RS485				RS232	RS422/RS485
GND		1		33	RxD6	TxD6+/Dx6+
TxD0	TxD0-/Dx0-	2		34	RTS6	RxD6-
RxD0	TxD0+/Dx0+	3		35	CTS6	RxD6+
RTS0	RxD0-	4		36	GND	
CTS0	RxD0+	5		37	TxD7	TxD7-/Dx7-
GND		6		38	RxD7	TxD7+/Dx7+
TxD1	TxD1-/Dx1-	7		39	RTS7	RxD7-
RxD1	TxD1+/Dx1+	8		40	CTS7	RxD7+
RTS1	RxD1-	9		41	GND	
CTS1	RxD1+	10		42	-	-
GND		11		43	-	-
TxD2	TxD2-/Dx2-	12		44	-	-
RxD2	TxD2+/Dx2+	13		45	-	-
RTS2	RxD2-	14		46	-	-
CTS2	RxD2+	15		47	-	-
GND		16		48	-	-
TxD3	TxD3-/Dx3-	17		49	-	-
RxD3	TxD3+/Dx3+	18		50	-	-
RTS3	RxD3-	19		51	-	-
CTS3	RxD3+	20		52	-	-
GND		21		53	-	-
TxD4	TxD4-/Dx4-	22		54	-	-
RxD4	TxD4+/Dx4+	23		55	-	-
RTS4	RxD4-	24		56	-	-
CTS4	RxD4+	25		57	-	-
GND		26		58	-	-
TxD5	TxD5-/Dx5-	27		59	-	-
RxD5	TxD5+/Dx5+	28		60	-	-
RTS5	RxD5-	29		61	-	-
CTS5	RxD5+	30		62	-	-
GND		31		63	-	-
TxD6	TxD6-/Dx6-	32		64	-	-

Table 7-3 : Pin Assignment P14 Back I/O Connector