



ADLINK
TECHNOLOGY INC.

cPCIS-6130R Series
1U Height Subsystem for
6U CompactPCI
User's Manual



Ehlbeek 15a
30938 Burgwedel
fon 05139-9980-0
fax 05139-9980-49

www.powerbridge.de
info@powerbridge.de

Manual Rev. 2.01
Revision Date: December 26, 2006
Part No: 50-15011-100



Recycled Paper

Advance Technologies; Automate the World.



Copyright 2005 ADLINK TECHNOLOGY INC.

All Rights Reserved.

The information in this document is subject to change without prior notice in order to improve reliability, design, and function and does not represent a commitment on the part of the manufacturer.

In no event will the manufacturer be liable for direct, indirect, special, incidental, or consequential damages arising out of the use or inability to use the product or documentation, even if advised of the possibility of such damages.

This document contains proprietary information protected by copyright. All rights are reserved. No part of this manual may be reproduced by any mechanical, electronic, or other means in any form without prior written permission of the manufacturer.

Trademarks

Product names mentioned herein are used for identification purposes only and may be trademarks and/or registered trademarks of their respective companies.

Getting Service from ADLINK

Customer Satisfaction is top priority for ADLINK Technology Inc. Please contact us should you require any service or assistance.

ADLINK TECHNOLOGY INC.

Web Site: <http://www.adlinktech.com>
 Sales & Service: Service@adlinktech.com
 TEL: +886-2-82265877
 FAX: +886-2-82265717
 Address: 9F, No. 166, Jian Yi Road, Chungho City,
 Taipei, 235 Taiwan

Please email or FAX this completed service form for prompt and satisfactory service.

Company Information	
Company/Organization	
Contact Person	
E-mail Address	
Address	
Country	
TEL	FAX:
Web Site	
Product Information	
Product Model	
Environment	OS: M/B: CPU: Chipset: BIOS:

Please give a detailed description of the problem(s):



Table of Contents

Table of Contents	i
List of Figures	iii
1 Introduction	1
1.1 Features.....	1
General	1
Boards Space	2
CompactPCI Compliancy	2
Enclosure	2
1.2 Specifications.....	2
1.3 Mechanical Layout.....	3
1.4 Compatible CPU Modules	4
1.5 Customized Systems	4
2 Getting Started	5
2.1 Shipping Contents	5
2.2 CompactPCI Card Installation	5
2.3 Rear Transition Module Installation/Removal	7
2.4 Powering Up the System	8
3 Backplanes	9
3.1 Features.....	9
3.2 Specifications.....	9
3.3 Mechanical Drawing	10
3.4 Connector and Jumpers	11
4 Cooling System	23
4.1 Air Filter Replacement (cPCIS-6400U only).....	23
4.2 Fan Specifications	24
5 Power Supply Unit	25
5.1 cPCIS-6130R: APS-120XU	25
Features	25
Specifications	25
Output Characteristics	25
Mechanical Drawing	26

5.2	cPCIS-6130R/DC4: APS-115XU	26
	Features	26
	Specifications	27
	Output Characteristics	27
	Mechanical Drawing	27
	Important Safety Instructions.....	29
	Warranty Policy	31

List of Figures

Figure 1-1:	cPCIS-6130R Front View	3
Figure 1-2:	cPCIS-6130R Rear View	3
Figure 1-3:	cPCIS-6130R Left View	3
Figure 1-4:	cPCIS-6130R Right View	3
Figure 2-1:	Installing a 6U SBC module.....	6
Figure 2-2:	Latching the cPCI module handles securely.	7
Figure 2-3:	cPCIS-6130R Series switches and LED.....	8
Figure 3-1:	cBP-6105R Backplane Front View	10
Figure 3-2:	cBP-6105R Backplane Rear View.....	10
Figure 4-1:	Air filter removal and replacement.....	23

1 Introduction

The cPCIS-6130R Series subsystem is designed for Telecom Data Center and Enterprise applications requiring a low profile PICMG 2.0 R3.0 CompactPCI compliant chassis with PICMIG 2.1 R2.0 hot swap support. The chassis is 1U height and standard 19" rack mount width for 6U cPCI cards, has a 2-slot board space, a hot swap backplane, a 64-bit/66MHz cPCI bus, and provides rear I/O for 80mm RTMs.

The cPCIS-6130R is equipped with an ATX 200W AC power supply (cPCIS-6130R/DC4 has a 150W DC PSU) and efficient cooling with 7 fans to meet the needs of a highly integrated single slot system board and matching peripheral. Guarded power and reset switches prevent accidental resets and a removable air filter provides for convenient maintenance.

1.1 Features

General

- ▶ 19" rackmount, 1U height chassis provides 2 slots for 6U cPCI cards with 80mm RTMs for front and rear I/O access
- ▶ PICMG 2.0 R3.0, PICMG 2.1 Hot Swap compliant 64-bit/66MHz 2-slot CompactPCI backplane with P3 & P5 rear I/O (one system slot and one peripheral slot)
- ▶ 2+1 hot swappable 500W+250W redundant power supplies with universal AC input (cPCIS-6400U)
- ▶ Built-in 200W 1U AC/ATX Power Supply or 150W 1U DC-48V/ATX with cooling fan
- ▶ Two intake fans and four exhaust fans provide efficient cooling. Intake fans have removable air filter for convenient maintenance.
- ▶ Guarded power switch and reset button
- ▶ Power LED
- ▶ Comprehensive EMC shielding: EMC gaskets are installed on bottom edges of both front and rear panel apertures

Boards Space

- ▶ Board space supports standard 6U height and 2-slot width
- ▶ Accommodates single or dual-slot system boards.
- ▶ Both front and rear access possible

CompactPCI Compliancy

- ▶ PICMG 2.0 R3.0 CompactPCI Core Specification
- ▶ PICMG 2.1 R2.0 CompactPCI Hot Swap

Enclosure

- ▶ EIA RS-310C 19" 1U high rackmount enclosure
- ▶ Coated metal plate outer covering

1.2 Specifications

CompactPCI Standards	PICMG 2.0; 2.1
Form Factor	6U cPCI with 80 mm depth rear I/O
Enclosure	EIA RS-310C 19" 1U high rack-mount enclosure Coated metal plate outer covering Guarded power switch and reset button
Cooling System	Two intake fans with removable air filter, four exhaust fans (see Chapter 4 Cooling for details)
Power Supply	200W 1U AC/ATX Power Supply or 150W 1U DC-48V/ATX with cooling fan
Dimension	482.6 x 43.9 x 296.2 (mm, WxHxD, including brackets)
Operating Temperature	0 to 45°C (depending on system configuration)
Storage Temperature	-20 to 80°C
Humidity	5% to 95%, non-condensing
Shock	15G peak-to-peak, 11ms duration, non-operation
Vibration	Non-operation: 1.88Grms, 5-500Hz, each axis Operation: 0.5Grms, 5-500Hz, each axis
Safety, Certification, EBS	CE, FCC class A, Designed for NEBS Level 3

1.3 Mechanical Layout

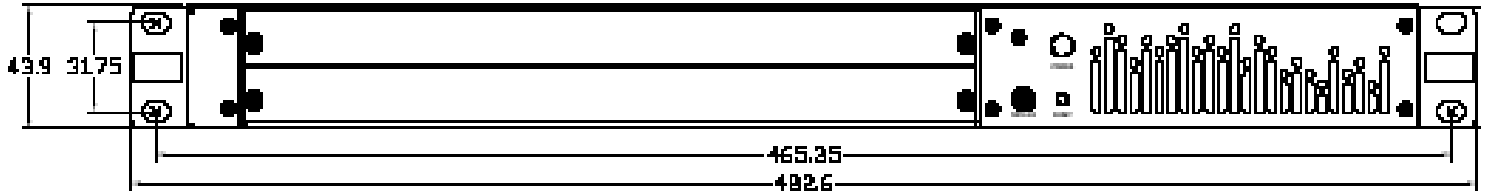

Figure 1-1: cPCIS-6130R Front View

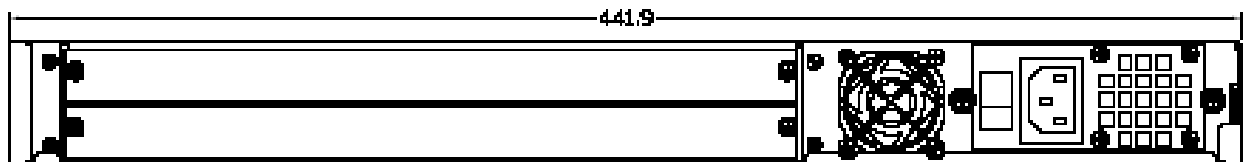

Figure 1-2: cPCIS-6130R Rear View



Figure 1-3: cPCIS-6130R Left View

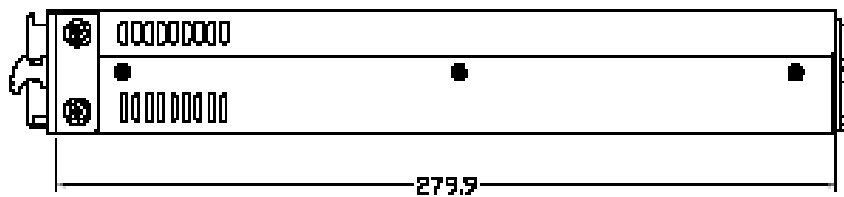

Figure 1-4: cPCIS-6130R Right View

1.4 Compatible CPU Modules

For complete systems, users must order CPU modules in addition to the subsystem. The following table lists which ADLINK CompactPCI CPU modules are compatible with the cPCIS-6130R Series models.

CPU Module	64-bit/66MHz
cPCI-6860A	yes
cPCI-6840	yes
cPCI-6830	yes
cPCI-6820	yes
cPCI-6810	yes
cPCI-6780	yes
cPCI-6765/6765A	yes
cPCI-6760D	—

1.5 Customized Systems

Subsystems can be customized to meet the specific needs of your application. To customize a subsystem please contact an ADLINK dealer, or visit the *Where to Buy* page of our website for more information: <http://www.adlinktech.com>.

2 Getting Started

This chapter describes the unpacking procedure of the subsystem and installation procedures for CompactPCI boards and power supply units (PSUs), and hard drive rack operation procedures.

2.1 Shipping Contents

Check the shipping carton for any damage. If the shipping carton and contents are damaged, please notify the dealer for a replacement. Retain the shipping carton and packing material for inspection by the dealer. Obtain authorization before returning any product to ADLINK.

Check that the following items are included in the package. If there are any missing items, please contact your dealer:

- ▶ One cPCIS-6130R Subsystem
- ▶ Accessory Package: includes power cords, replacement air filter, ergonomic rackmount handles, and pouch containing screws, zip ties, etc.
- ▶ This User's Manual

2.2 CompactPCI Card Installation

CompactPCI connectors are rigid, and therefore require careful handling when inserted and removed. Improper manipulation of the cards will result in damage to the backplane.

System slots usually have some obvious indicators, something like red card guide rail, triangle mark enclosing the slot number on the backplane. The system card only can be installed in the system slot, and do not insert system card into any other slot, or insert any peripheral card into system slot.

The handles on CompactPCI card helps users to install or remove easily and safety. Please follow the procedures below to install a CompactPCI module into a chassis:

The handles on CompactPCI cards and PSUs ensure simple and safe installation and removal. Please follow the procedures below to install a CompactPCI module into a chassis:

1. Place the subsystem on a level surface or rackmount it. Remove the blanking plates where required by undoing the retaining screws at each end. Retain the blanking plates for possible future use. The system should not be put into use without blanking plates for all empty slots, otherwise the EMC and cooling performance will be compromised.
2. Hold the SBC module or peripheral card horizontally. Make sure that the handles are unlatched (i.e. that they are spread outwards). If necessary, unlatch the handle by pressing on the release button with your thumb.

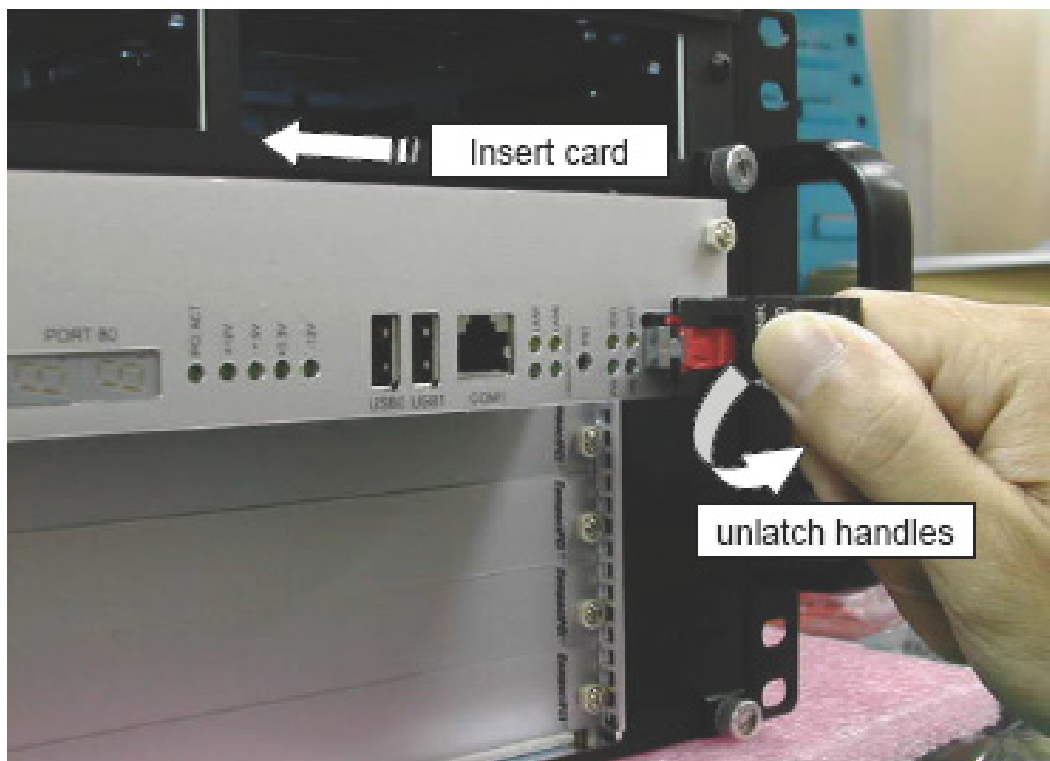

Figure 2-1: Installing a 6U SBC module

3. Carefully insert the module into the desired slot by sliding the edges of the board into the appropriate card guide rail. Take care to ensure correct alignment of the card with the chassis during insertion to prevent damage to the card and/or backplane.

4. Continue inserting the card until the handles engage with the chassis.
5. Pull inwards on the handles for final insertion. Ensure that the red buttons on the handles fully latch into position as unless this is done the card is not correctly inserted. Fasten the retaining screws at each end of the card (2 for single slot cards, 4 for double slot cards)



Figure 2-2: Latching the cPCI module handles securely.

6. To remove the module, undo the retaining screws, press the red release buttons, and reverse steps 1 through 5 above.

2.3 Rear Transition Module Installation/Removal

The installation and removal procedures for a Rear Transition Module (RTM) are the same as those for CompactPCI boards. Because they are shorter than front boards, pay careful attention when inserting or removing RTMs. Only models with an “R” at the end of the model number support RTMs.

Note: We strongly recommended the use of RTMs with AB type connectors to prevent the damage to the backplane during RTM installation.

2.4 Powering Up the System

Connect the supplied power cord to the socket on the back of the chassis. Insert the desired boards into the appropriate card slots as described in Sections 2.2 and 2.3. Turn on the main power switch next to the power cord connector.

The cPCIS-6130R subsystems feature a guarded power switch and reset button that provide ATX power control capability. Use the tool provided in the Accessory Packet or a suitably shaped object (such as a pen) to actuate the power switch and reset button. The Power LED indicates that both the rear main power switch and guarded ATX power switch are turned on.

Refer to the diagram below for LED and switch locations.

cPCIS-6130R Series

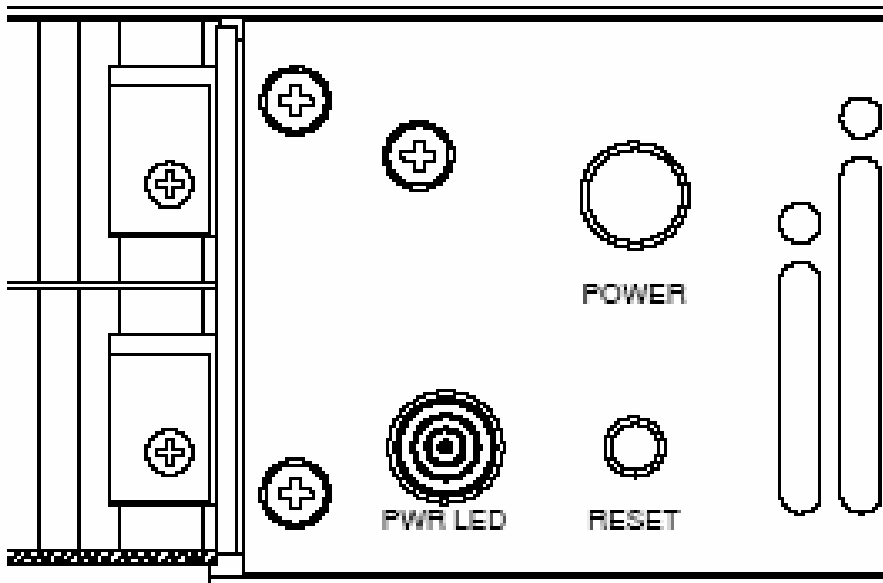

Figure 2-3: cPCIS-6130R Series switches and LED

3 Backplanes

In this chapter, we will describe the backplane for the cPCIS-6130R Series, the cBP-6402R.

3.1 Features

- ▶ Standard CompactPCI for 6U cPCI cards
- ▶ Suitable for one single-slot system module and one expansion card, or one dual system module.
- ▶ Supports 80mm rear I/O for each slot
- ▶ PICMG 2.1 Hot Swap compliant 64-bit 2-slot CompactPCI backplane with P3 & P5 rear I/O

3.2 Specifications

- ▶ CompactPCI Compliancy
 - ▷ PICMG 2.0 CompactPCI core specification R3.0
 - ▷ PICMG 2.1 CompactPCI hot swap R2.0
- ▶ Dimension: 321.5 x 39.64 (mm, W x H)
- ▶ PCI bus clock: 64-bit/66MHz
- ▶ System slot rear I/O: P3, P4 and P5 rear I/O with AB type shroud
- ▶ Peripheral slots: one
- ▶ V (I/O): 3.3V or 5V selectable, default 5V
- ▶ Power Connectors: ATX connector x1
- ▶ System slot legacy I/O: FDD, IDE1, and IDE2 (pin compatible with cPCI-6760D and cPCI-6780 only)
- ▶ Other connectors: Power Switch, Reset Button, Fans, Power LED, Speaker

3.3 Mechanical Drawing

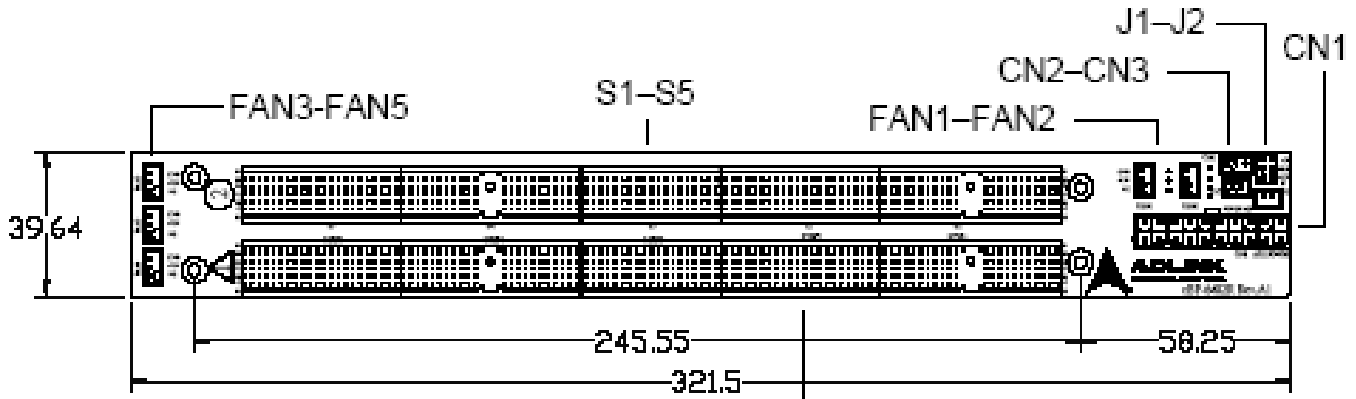

Figure 3-1: cBP-6105R Backplane Front View

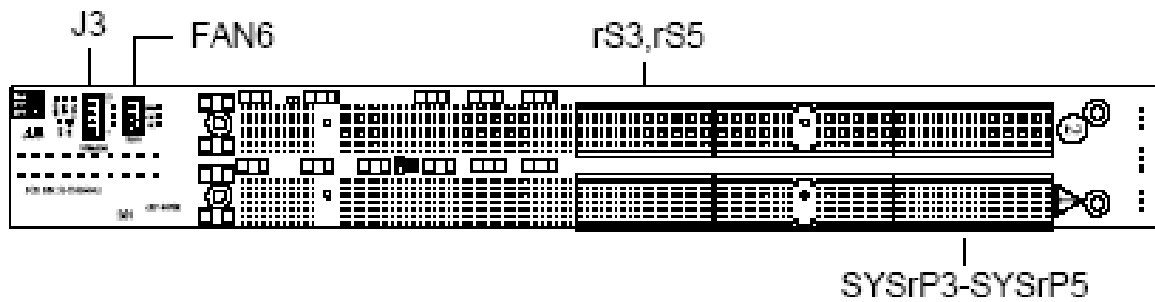
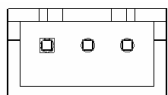

Figure 3-2: cBP-6105R Backplane Rear View

3.4 Connector and Jumpers

Fan Connectors [Fan1 – Fan6]



Pin	Signal
1	NC
2	12V
3	GND

V(I/O) Select [J1]

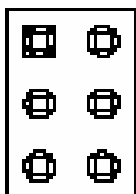

Pin	Signal	Pin	Signal
1	+5V	2	+5V
3	V(I/O)	4	V(I/O)
5	+3.3V	6	+3.3V

(default: J4-J5 shorted – jumpers must be set in pairs)

Power LED [J2]

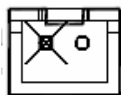

Pin	Signal
1	+5V
2	GND

Speaker [J3]



Pin	Signal
1	+5V
2	NC
3	NC
4	BUZZER

ATX Power Connector [CN1]

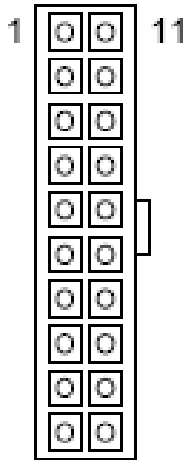

Pin	Signal	Pin	Signal
1	+3.3V	11	+3.3V
2	+3.3V	12	-12V
3	GND	13	GND
4	+5V	14	PS_ON_L
5	GND	15	GND
6	+5V	16	GND
7	GND	17	GND
8	PWRGOOD	18	-5V
9	STB5V	19	+5V
10	+12V	20	+5V

ATX Power Switch [CN2]

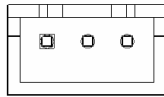

Pin	Signal
1	Power On
2	GND
3	+5VSb

Reset Button [CN3]

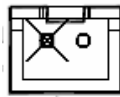

Pin	Signal
1	RESET#
2	GND

System Slot: [SYSP1]

Pin	Z	A	B	C	D	E	F
25	GND	+5V	REQ64#	ENUM#	+3.3V	+5V	GND
24	GND	AD[1]	+5V	V(I/O)	AD[0]	ACK64#	GND
23	GND	+3.3V	AD[4]	AD[3]	+5V	AD[2]	GND
22	GND	AD[7]	GND	+3.3V	AD[6]	AD[5]	GND
21	GND	+3.3V	AD[9]	AD[8]	M66EN	C/BE[0]#	GND
20	GND	AD[12]	GND	V(I/O)	AD[11]	AD[10]	GND
19	GND	+3.3V	AD[15]	AD[14]	GND	AD[13]	GND
18	GND	SERR#	GND	+3.3V	PAR	C/BE[1]#	GND
17	GND	+3.3V	IPMB_SCL	IPMB_SDA	GND	PERR#	GND
16	GND	DEVSEL#	GND	V(I/O)	STOP#	LOCK#	GND
15	GND	+3.3V	FRAME#	IRDY#	BDSEL	TRDY#	GND
12-14	Keying Area						
11	GND	AD[18]	AD[17]	AD[16]	GND	C/BE[2]#	GND
10	GND	AD[21]	GND	+3.3V	AD[20]	AD[19]	GND
9	GND	C/BE[3]#	GND	AD[23]	GND	AD[22]	GND
8	GND	AD[26]	GND	V(I/O)	AD[25]	AD[24]	GND
7	GND	AD[30]	AD[29]	AD[28]	GND	AD[27]	GND
6	GND	REQ#	GND	+3.3V	CLK	AD[31]	GND
5	GND	Reserved	Reserved	PCIRST#	GND	GNT#	GND
4	GND	IPMB_PWR	HEALTHY#	V(I/O)	INTP	INTS	GND
3	GND	INTA#	INTB#	INTC#	+5V	INTD#	GND
2	GND	TCK	+5V	TMS	TDO	TDI	GND
1	GND	+5V	-12V	TRST#	+12V	+5V	GND

System Slot: [SYSP2]

Pin	Z	A	B	C	D	E	F
22	GND	GND	GND	GND	GND	NC	GND
21	GND	NC	GND	NC	NC	NC	GND
20	GND	NC	GND	NC	GND	NC)	GND
19	GND	GND	GND	NC	NC	NC	GND
18	GND	RVA43)	RVB43	RVC43	GND	RVE43	GND
17	GND	RVA42	GND	RESET#	NC	NC	GND
16	GND	RVA41	RVB41	NC	GND	RVE41	GND
15	GND	RVA40	GND	FAL#	NC	NC	GND
14	GND	AD [35]	AD [34]	AD [33]	GND	AD [32]	GND
13	GND	AD [38]	GND	V (I/O)	AD [37]	AD [36]	GND
12	GND	AD [42]	AD [41]	AD [40]	GND	AD [39]	GND
11	GND	AD [45]	GND	V (I/O)	AD [44]	AD [43]	GND
10	GND	AD [49]	AD [48]	AD [47]	GND	AD [46]	GND
9	GND	AD [52]	GND	V (I/O)	AD [51]	AD [50]	GND
8	GND	AD [56]	AD [55]	AD [54]	GND	AD [53]	GND
7	GND	AD [59]	GND	V (I/O)	AD [58]	AD [57]	GND
6	GND	AD [63]	AD [62]	AD [61]	GND	AD [60]	GND
5	GND	C/BE [5]#	GND	V (I/O)	C/BE [4]#	PAR 64	GND
4	GND	V (I/O)	RVB29	C/BE [7]#	GND	C/BE [6]#	GND
3	GND	NC	GND	NC	NC	NC	GND
2	GND	NC	NC	GND	NC	NC	GND
1	GND	NC	GND	NC	NC	NC	GND

System Slot: [SYSP3]

Pin	Z	A	B	C	D	E	F
19	GND	NC	NC	NC	NC	NC	GND
18	GND	NC	NC	NC	NC	NC	GND
17	GND	NC	NC	NC	NC	NC	GND
16	GND	NC	NC	NC	NC	NC	GND
15	GND	NC	NC	NC	NC	NC	GND
14	GND	NC	NC	NC	NC	NC	GND
13	GND	NC	NC	NC	NC	NC	GND
12	GND	NC	NC	NC	NC	NC	GND
11	GND	NC	NC	NC	NC	NC	GND
10	GND	NC	NC	NC	NC	NC	GND
9	GND	NC	NC	NC	NC	NC	GND
8	GND	NC	NC	NC	NC	NC	GND
7	GND	NC	NC	NC	NC	NC	GND
6	GND	NC	NC	NC	NC	NC	GND
5	GND	NC	NC	BUZZER	NC	NC	GND
4	GND	NC	NC	NC	NC	NC	GND
3	GND	NC	NC	NC	NC	NC	GND
2	GND	NC	NC	NC	NC	NC	GND
1	GND	NC	NC	NC	NC	NC	GND

System Slot: [SYSP4]

Pin	Z	A	B	C	D	E	F
25	GND	NC	NC	NC	NC	NC	GND
24	GND	NC	NC	NC	NC	NC	GND
23	GND	NC	NC	NC	NC	NC	GND
22	GND	NC	NC	NC	NC	NC	GND
21	GND	NC	NC	NC	NC	NC	GND
20	GND	NC	NC	NC	NC	NC	GND
19	GND	NC	NC	NC	NC	NC	GND
18	GND	NC	NC	NC	NC	NC	GND
17	GND	NC	NC	NC	NC	NC	GND
16	GND	NC	NC	NC	NC	NC	GND
15	GND	NC	NC	NC	NC	NC	GND
12-14	Keying Area						
11	GND	NC	NC	NC	NC	NC	GND
10	GND	NC	NC	NC	NC	NC	GND
9	GND	NC	NC	NC	NC	NC	GND
8	GND	NC	NC	NC	NC	NC	GND
7	GND	NC	NC	NC	NC	NC	GND
6	GND	NC	NC	NC	NC	NC	GND
5	GND	NC	NC	NC	NC	NC	GND
4	GND	NC	NC	NC	NC	NC	GND
3	GND	NC	NC	NC	NC	NC	GND
2	GND	NC	NC	NC	NC	NC	GND
1	GND	NC	NC	NC	NC	NC	GND

System Slot: [SYSP5]

Pin	Z	A	B	C	D	E	F
22	GND	NC	NC	NC	NC	NC	GND
21	GND	NC	NC	NC	NC	NC	GND
20	GND	NC	NC	NC	NC	NC	GND
19	GND	NC	NC	NC	NC	NC	GND
18	GND	NC	NC	NC	NC	NC	GND
17	GND	NC	NC	NC	NC	NC	GND
16	GND	NC	NC	NC	NC	NC	GND
15	GND	NC	NC	NC	NC	NC	GND
14	GND	NC	NC	NC	NC	NC	GND
13	GND	NC	NC	NC	NC	NC	GND
12	GND	NC	NC	NC	NC	NC	GND
11	GND	NC	NC	NC	NC	NC	GND
10	GND	NC	NC	NC	NC	NC	GND
9	GND	NC	NC	NC	NC	NC	GND
8	GND	NC	NC	NC	NC	NC	GND
7	GND	NC	NC	NC	NC	NC	GND
6	GND	NC	NC	NC	NC	NC	GND
5	GND	NC	NC	NC	NC	NC	GND
4	GND	NC	NC	NC	NC	NC	GND
3	GND	NC	NC	NC	NC	NC	GND
2	GND	NC	NC	NC	NC	NC	GND
1	GND	NC	NC	NC	NC	NC	GND

Peripheral Slot: [P1]

Pin	Z	A	B	C	D	E	F
25	GND	+5V	REQ64#	ENUM#	+3.3V	+5V	GND
24	GND	AD[1]	+5V	V(I/O)	AD[0]	ACK64#	GND
23	GND	+3.3V	AD[4]	AD[3]	+5V	AD[2]	GND
22	GND	AD[7]	GND	+3.3V	AD[6]	AD[5]	GND
21	GND	+3.3V	AD[9]	AD[8]	M66EN	C/BE[0]#	GND
20	GND	AD[12]	GND	V(I/O)	AD[11]	AD[10]	GND
19	GND	+3.3V	AD[15]	AD[14]	GND	AD[13]	GND
18	GND	SERR#	GND	+3.3V	PAR	C/BE[1]#	GND
17	GND	+3.3V	IPMB_SCL	IPMB_SDA	GND	PERR#	GND
16	GND	DEVSEL#	GND	V(I/O)	STOP#	LOCK#	GND
15	GND	+3.3V	FRAME#	IRDY#	BDSEL	TRDY#	GND
12-14	Keying Area						
11	GND	AD[18]	AD[17]	AD[16]	GND	C/BE[2]#	GND
10	GND	AD[21]	GND	+3.3V	AD[20]	AD[19]	GND
9	GND	C/BE[3]#	IDSEL	AD[23]	GND	AD[22]	GND
8	GND	AD[26]	GND	V(I/O)	AD[25]	AD[24]	GND
7	GND	AD[30]	AD[29]	AD[28]	GND	AD[27]	GND
6	GND	REQ#	GND	+3.3V	CLK	AD[31]	GND
5	GND	Reserved	Reserved	PCIRST#	GND	GNT#	GND
4	GND	IPMB_PWR	HEALTHY#	V(I/O)	INTP	INTS	GND
3	GND	INTA#	INTB#	INTC#	+5V	INTD#	GND
2	GND	TCK	+5V	TMS	TDO	TDI	GND
1	GND	+5V	-12V	TRST#	+12V	+5V	GND

Peripheral Slot: [P2]

Pin	Z	A	B	C	D	E	F
22	GND	GND	GND	GND	NC	GND	GND
21	GND	NC	NC	NC	NC	NC	GND
20	GND	NC	NC	NC	GND	NC)	GND
19	GND	NC	NC	NC	NC	NC	GND
18	GND	RVA43)	RVB43	RVC43	GND	RVE43	GND
17	GND	RVA42	GND	RESET#	NC	NC	GND
16	GND	RVA41	RVB41	NC	GND	RVE41	GND
15	GND	RVA40	GND	NC	NC	NC	GND
14	GND	AD [35]	AD [34]	AD [33]	GND	AD [32]	GND
13	GND	AD [38]	GND	V (I/O)	AD [37]	AD [36]	GND
12	GND	AD [42]	AD [41]	AD [40]	GND	AD [39]	GND
11	GND	AD [45]	GND	V (I/O)	AD [44]	AD [43]	GND
10	GND	AD [49]	AD [48]	AD [47]	GND	AD [46]	GND
9	GND	AD [52]	GND	V (I/O)	AD [51]	AD [50]	GND
8	GND	AD [56]	AD [55]	AD [54]	GND	AD [53]	GND
7	GND	AD [59]	GND	V (I/O)	AD [58]	AD [57]	GND
6	GND	AD [63]	AD [62]	AD [61]	GND	AD [60]	GND
5	GND	C/BE [5]#	GND	V (I/O)	C/BE [4]#	PAR 64	GND
4	GND	V (I/O)	RVB29	C/BE [7]#	GND	C/BE [6]#	GND
3	GND	NC	GND	NC	NC	NC	GND
2	GND	NC	NC	NC	NC	NC	GND
1	GND	NC	GND	NC	NC	NC	GND

Peripheral Slot: [P3]

Pin	Z	A	B	C	D	E	F
19	GND	NC	NC	NC	NC	NC	GND
18	GND	NC	NC	NC	NC	NC	GND
17	GND	NC	NC	NC	NC	NC	GND
16	GND	NC	NC	NC	NC	NC	GND
15	GND	NC	NC	NC	NC	NC	GND
14	GND	NC	NC	NC	NC	NC	GND
13	GND	NC	NC	NC	NC	NC	GND
12	GND	NC	NC	NC	NC	NC	GND
11	GND	NC	NC	NC	NC	NC	GND
10	GND	NC	NC	NC	NC	NC	GND
9	GND	NC	NC	NC	NC	NC	GND
8	GND	NC	NC	NC	NC	NC	GND
7	GND	NC	NC	NC	NC	NC	GND
6	GND	NC	NC	NC	NC	NC	GND
5	GND	NC	NC	NC	NC	NC	GND
4	GND	NC	NC	NC	NC	NC	GND
3	GND	NC	NC	NC	NC	NC	GND
2	GND	NC	NC	NC	NC	NC	GND
1	GND	NC	NC	NC	NC	NC	GND

Peripheral Slot: [2-P4] - [5-P4]

Pin	Z	A	B	C	D	E	F
25	GND	NC	NC	NC	NC	NC	GND
24	GND	NC	NC	NC	NC	NC	GND
23	GND	NC	NC	NC	NC	NC	GND
22	GND	NC	NC	NC	NC	NC	GND
21	GND	NC	NC	NC	NC	NC	GND
20	GND	NC	NC	NC	NC	NC	GND
19	GND	NC	NC	NC	NC	NC	GND
18	GND	NC	NC	NC	NC	NC	GND
17	GND	NC	NC	NC	NC	NC	GND
16	GND	NC	NC	NC	NC	NC	GND
15	GND	NC	NC	NC	NC	NC	GND
12-14	Keying Area						
11	GND	NC	NC	NC	NC	NC	GND
10	GND	NC	NC	NC	NC	NC	GND
9	GND	NC	NC	NC	NC	NC	GND
8	GND	NC	NC	NC	NC	NC	GND
7	GND	NC	NC	NC	NC	NC	GND
6	GND	NC	NC	NC	NC	NC	GND
5	GND	NC	NC	NC	NC	NC	GND
4	GND	NC	NC	NC	NC	NC	GND
3	GND	NC	NC	NC	NC	NC	GND
2	GND	NC	NC	NC	NC	NC	GND
1	GND	NC	NC	NC	NC	NC	GND

Peripheral Slot: [2–P5] - [5–P5]

Pin	Z	A	B	C	D	E	F
22	GND	NC	NC	NC	NC	NC	GND
21	GND	NC	NC	NC	NC	NC	GND
20	GND	NC	NC	NC	NC	NC	GND
19	GND	NC	NC	NC	NC	NC	GND
18	GND	NC	NC	NC	NC	NC	GND
17	GND	NC	NC	NC	NC	NC	GND
16	GND	NC	NC	NC	NC	NC	GND
15	GND	NC	NC	NC	NC	NC	GND
14	GND	NC	NC	NC	NC	NC	GND
13	GND	NC	NC	NC	NC	NC	GND
12	GND	NC	NC	NC	NC	NC	GND
11	GND	NC	NC	NC	NC	NC	GND
10	GND	NC	NC	NC	NC	NC	GND
9	GND	NC	NC	NC	NC	NC	GND
8	GND	NC	NC	NC	NC	NC	GND
7	GND	NC	NC	NC	NC	NC	GND
6	GND	NC	NC	NC	NC	NC	GND
5	GND	NC	NC	NC	NC	NC	GND
4	GND	NC	NC	NC	NC	NC	GND
3	GND	NC	NC	NC	NC	NC	GND
2	GND	NC	NC	NC	NC	NC	GND
1	GND	NC	NC	NC	NC	NC	GND

4 Cooling System

The cPCIS-6130R Series subsystems are equipped with several fans to provide cooling for the system board, peripheral card and power supply unit. The intake fans have a replaceable air filter.

Only cPCIS-6130R fan units are hot-swappable. Fan modules other than the front-access intake fan require the user to manually disconnect the power cable.

4.1 Air Filter Replacement (cPCIS-6400U only)

To ensure proper performance of the system, the air filter should be cleaned or replaced as necessary. A replacement air filter is supplied and can be found in the Accessory Packet.

Air Filter Removal and Replacement Procedure

1. Remove the front-access intake fan module as shown in Figure 4.3 above.
2. Lay the fan module on its side, remove the four screws securing the filter cover, and lift the cover to expose the filter element.

Figure 4-1: Air filter removal and replacement

3. Clean the existing filter or replace it with the one provided.

4. Place the filter back in position, replace the filter cover and screws, and reinstall the filter module into the chassis.

4.2 Fan Specifications

SUNON KDE1204PKVX

(right side intake fans x2 and rear exhaust fan x1)

- ▷ Dimensions: 40 x 40 x 20mm
- ▷ Weight: 30 g
- ▷ Type: DC brushless
- ▷ Rated voltage: 12V
- ▷ Rated Current: 0.13 A
- ▷ Rated Power: 1.6 W
- ▷ Fan speed: 8200RPM
- ▷ Max air flow: 10.8 CFM
- ▷ Acoustical Noise: 27.5 dBA/each

NMB 1606KL-04W-B50 (left side exhaust fans x3)

- ▷ Dimensions: 40 x 40 x 20mm
- ▷ Weight: 20g
- ▷ Type: DC brushless
- ▷ Rated voltage: 12V
- ▷ Rated Current: 0.085 A
- ▷ Rated Power: 1.02W
- ▷ Fan speed: 8000RPM
- ▷ Max air flow: 8CFM
- ▷ Acoustical Noise: 34dBA/each

5 Power Supply Unit

The power supply options for the cPCIS-6130R Series are as follows: The cPCIS-6130R is equipped with the APS-120XU and the cPCIS-6130R/DC4 is equipped with the APS-115XU. Both are ATX power supplies.

5.1 cPCIS-6130R: APS-120XU

Features

- ▶ Active PFC (full range), meet IEC-1000-3-2 CLASS D
- ▶ 12V Max. current : 9A
- ▶ Temperature range: Operating 0? ~ 40?.
- ▶ EMI noise filter: FCC CLASS B, CISPR22 CLASS B
- ▶ Safety: UL 1950, CSA 22.2 NO/ 950, TUV IEC 950
- ▶ Cooling: TWO 40 mm NMB ball bearing DC Fans

Specifications

- ▶ Output Watts: 200W
- ▶ Dimensions: 190x100x40 (mm)
- ▶ AC Input Voltage: 90 ~ 264 VAC Full Range
- ▶ MTBF: 84,228 Hours

Output Characteristics

Output Voltage	Output Current (A)		Regulation Load	Regulation Line.	Output Ripple & Noise Max. [P-P]
	MIN.	MAX.			
5V	2	16	± 5%	± 1%	70mV
12V	1	7	± 5%	± 1%	120mV
-5V	0.1	0.2	± 5%	± 1%	100mV
-12V	0.1	0.7	~±10%	± 1%	120mV
3.3V	1	14	± 5%	± 1%	70mV
+5VSB	0.1	1.5	± 5%	± 1%	70mV

- Remarks**
1. The output power of 5V & 3.3V may not exceed 110 watts
 2. Total output power may not exceed 200 watts

Mechanical Drawing

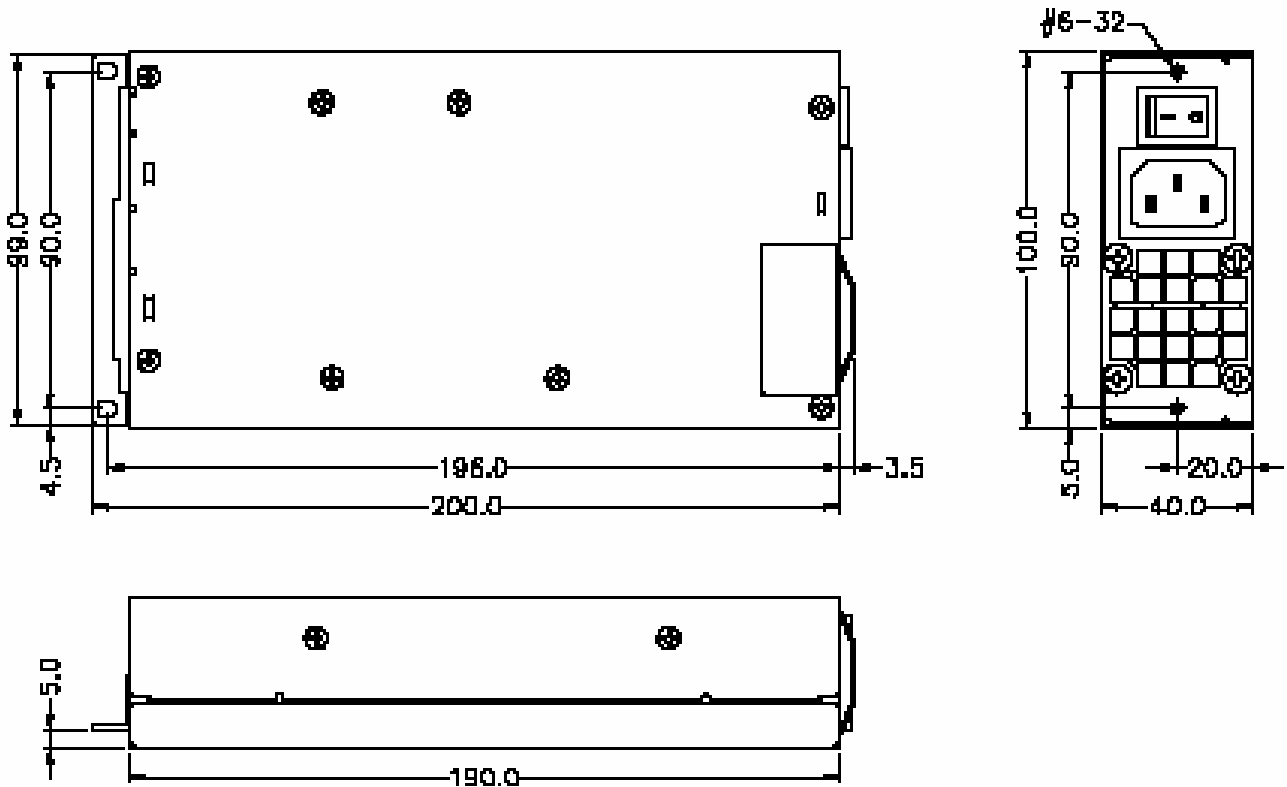

5.2 cPCIS-6130R/DC4: APS-115XU

Features

- ▶ DC -48V input
- ▶ 12V Max. current : 7A
- ▶ Temperature range: Operating 0? ~ 50?
- ▶ Humidity: Operating:20%-95%, Non-operating:10%-95%
- ▶ Remarks:85% is normal condition and 95% is with special coating process
- ▶ EMI noise filter: FCC CLASS A, CISPR22 CLASS A
- ▶ Safety: UL 1950, CSA 22.2 NO/ 950, TUV IEC 950
- ▶ Cooling: One 40 mm DC fan

Specifications

- ▶ Output Watts: 150W
- ▶ Dimensions: 190x100x40.5 (mm)
- ▶ DC Input Voltage: -40 to -56 VAC Full Range
- ▶ MTBF: 112,874 Hours

Output Characteristics

Output Voltage	Output Current (A)		Regulation Load	Regulation Line.	Output Ripple & Noise Max. [P-P]
	MIN.	MAX.			
5V	2	18	± 5%	± 1%	80mV
12V	1	6	± 8%	± 1%	120mV
-5V	0.1	0.5	± 10%	± 1%	120mV
-12V	0.1	1.0	-10%~+10%	± 1%	150mV
3.3V	1	10	± 5%	± 1%	80mV
+5VSB	0.1	1.5	± 5%	± 1%	50mV

- Remarks**
1. The output power of 5V & 3.3V may not exceed 100 watts
 2. Total output power may not exceed 200 watts

Mechanical Drawing

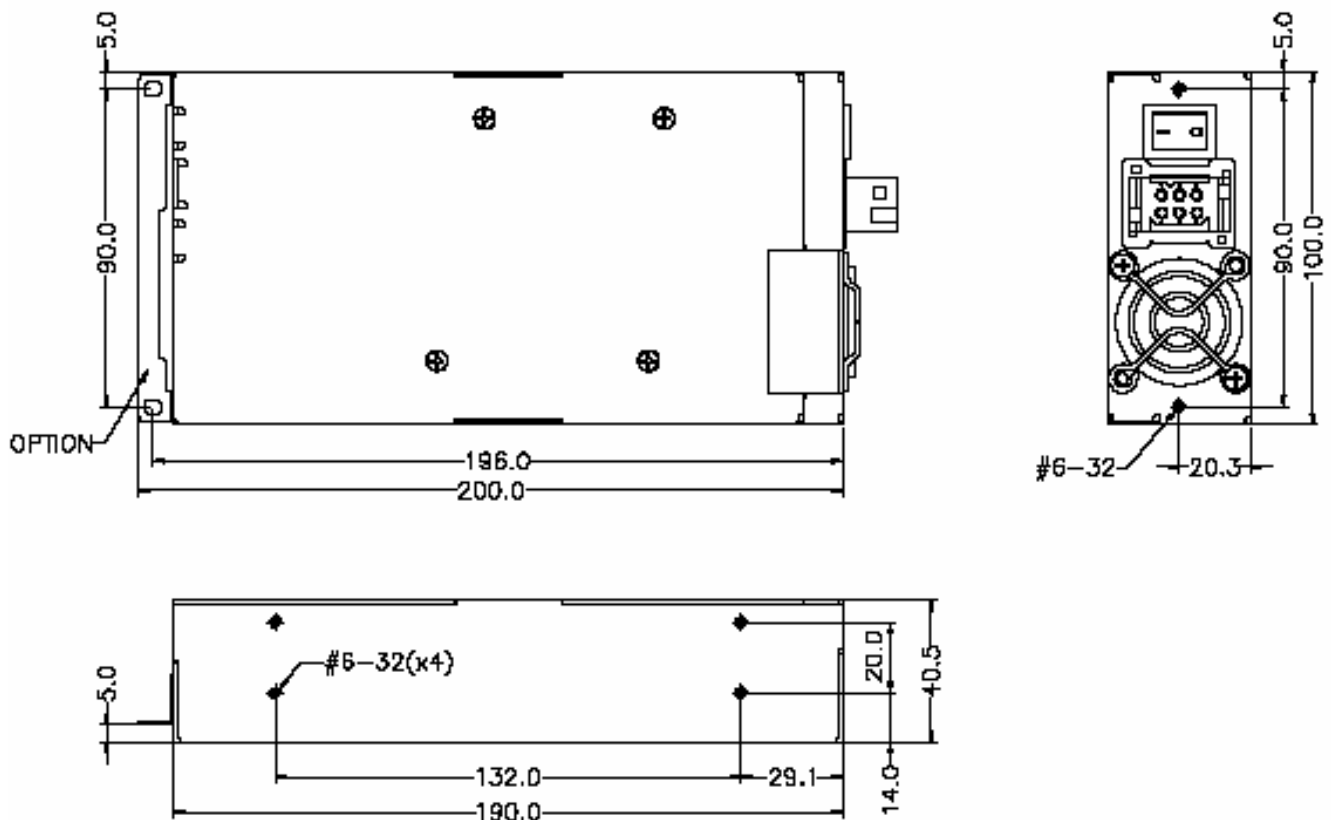

Important Safety Instructions

Please read and follow all instructions marked on the product and in the documentation before operating the system. Retain all safety and operating instructions for future use.

- ▶ Please read these safety instructions carefully.
- ▶ Please keep this User's Manual for future reference.
- ▶ The equipment should be operated in an ambient temperature between 0 and 50°C.
- ▶ The equipment should be operated only from the type of power source indicated on the rating label. Make sure the voltage of the power source is correct when connecting the equipment to the power outlet.
- ▶ If the user's equipment has a voltage selector switch, make sure that the switch is set to the proper position for the area. The voltage selector switch is set at the factory to the correct voltage.
- ▶ For pluggable equipment, ensure they are installed near a socket-outlet that is easily accessible.
- ▶ Secure the power cord to prevent unnecessary accidents. Do not place anything over the power cord.
- ▶ If the equipment will not be in use for long periods of time, disconnect the equipment from mains to avoid being damaged by transient overvoltage.
- ▶ All cautions and warnings on the equipment should be noted.
- ▶ Please keep this equipment away from humidity.
- ▶ Do not use this equipment near water or a heat source.
- ▶ Place this equipment on a reliable surface when installing. A drop or fall could cause injury.
- ▶ Never pour any liquid into the opening, this could cause fire or electrical shock.

- ▶ Openings in the case are provided for ventilation. Do not block or cover these openings. Make sure there is adequate space around the system for ventilation when setting up the work area. Never insert objects of any kind into the ventilation openings.
- ▶ To avoid electrical shock, always unplug all power and modem cables from the wall outlets before removing covers.
- ▶ Lithium Battery provided (real time clock battery)
“CAUTION - Risk of explosion if battery is replaced by an incorrect type. Dispose used batteries as instructed in the instructions”
- ▶ The equipment should be checked by service personnel if one of the following situation arises:
 - ▷ The power cord or plug is damaged.
 - ▷ Liquid has penetrated the equipment.
 - ▷ The equipment has been exposed to moisture.
 - ▷ The equipment is not functioning or does not function according to the user’s manual.
 - ▷ The equipment has been dropped and damaged.
 - ▷ If the equipment has obvious sign of breakage.
- ▶ Never open the equipment. For safety reasons, the equipment should only be opened by qualified service personnel.

Warranty Policy

Thank you for choosing ADLINK. To understand your rights and enjoy all the after-sales services we offer, please read the following carefully.

1. Before using ADLINK's products please read the user manual and follow the instructions exactly. When sending in damaged products for repair, please attach an RMA application form which can be downloaded from: <http://rma.adlinktech.com/policy/>.
2. All ADLINK products come with a limited two-year warranty, one year for products bought in China:
 - ▶ The warranty period starts on the day the product is shipped from ADLINK's factory.
 - ▶ Peripherals and third-party products not manufactured by ADLINK will be covered by the original manufacturers' warranty.
 - ▶ For products containing storage devices (hard drives, flash cards, etc.), please back up your data before sending them for repair. ADLINK is not responsible for any loss of data.
 - ▶ Please ensure the use of properly licensed software with our systems. ADLINK does not condone the use of pirated software and will not service systems using such software. ADLINK will not be held legally responsible for products shipped with unlicensed software installed by the user.
 - ▶ For general repairs, please do not include peripheral accessories. If peripherals need to be included, be certain to specify which items you sent on the RMA Request & Confirmation Form. ADLINK is not responsible for items not listed on the RMA Request & Confirmation Form.

3. Our repair service is not covered by ADLINK's guarantee in the following situations:
 - ▶ Damage caused by not following instructions in the User's Manual.
 - ▶ Damage caused by carelessness on the user's part during product transportation.
 - ▶ Damage caused by fire, earthquakes, floods, lightening, pollution, other acts of God, and/or incorrect usage of voltage transformers.
 - ▶ Damage caused by unsuitable storage environments (i.e. high temperatures, high humidity, or volatile chemicals).
 - ▶ Damage caused by leakage of battery fluid during or after change of batteries by customer/user.
 - ▶ Damage from improper repair by unauthorized ADLINK technicians.
 - ▶ Products with altered and/or damaged serial numbers are not entitled to our service.
 - ▶ This warranty is not transferable or extendible.
 - ▶ Other categories not protected under our warranty.
4. Customers are responsible for shipping costs to transport damaged products to our company or sales office.
5. To ensure the speed and quality of product repair, please download an RMA application form from our company website: <http://rma.adlinktech.com/policy>. Damaged products with attached RMA forms receive priority.

If you have any further questions, please email our FAE staff: service@adlinktech.com.