

The Embedded I/O Company



TXMC889

Four Channel SFP Gigabit Ethernet

Version 1.0

User Manual

Issue 1.0.0

November 2019



Ehlbeek 15a
30938 Burgwedel
fon 05139-9980-0
fax 05139-9980-49

www.powerbridge.de
info@powerbridge.de

TEWS TECHNOLOGIES GmbH

Am Bahnhof 7 25469 Halstenbek, Germany
Phone: +49 (0) 4101 4058 0 Fax: +49 (0) 4101 4058 19
e-mail: info@tews.com www.tews.com

TXMC889-10R

Four channel Gigabit Ethernet SFP front panel I/O

(RoHS compliant)

This document contains information, which is proprietary to TEWS TECHNOLOGIES GmbH. Any reproduction without written permission is forbidden.

TEWS TECHNOLOGIES GmbH has made any effort to ensure that this manual is accurate and complete. However TEWS TECHNOLOGIES GmbH reserves the right to change the product described in this document at any time without notice.

TEWS TECHNOLOGIES GmbH is not liable for any damage arising out of the application or use of the device described herein.

Style Conventions

Hexadecimal characters are specified with prefix 0x, i.e. 0x029E (that means hexadecimal value 029E).

For signals on hardware products, an 'Active Low' is represented by the signal name with # following, i.e. IP_RESET#.

Access terms are described as:

W Write Only

R Read Only

R/W Read/Write

R/C Read/Clear

R/S Read/Set

©2019 by TEWS TECHNOLOGIES GmbH

All trademarks mentioned are property of their respective owners.

Issue	Description	Date
1.0.0	Initial issue	November 2019

Table of Contents

1	PRODUCT DESCRIPTION	6
2	TECHNICAL SPECIFICATION	8
3	PCI INTERFACE	9
3.1	Multifunctional Device (Intel Corporation)	9
3.2	Identifiers	9
3.3	PCI Base Address Register Configuration	10
4	LEDS	11
5	PIN ASSIGNMENT – I/O CONNECTOR	12
5.1	XMC Connector P15.....	12
5.2	SFP Connector	13

List of Figures

FIGURE 1-1 : BLOCK DIAGRAM.....	7
FIGURE 4-1 : TXMC889 FRONT PANEL	11

List of Tables

TABLE 2-1 : TECHNICAL SPECIFICATION.....	8
TABLE 3-1 : BUS : DEVICE : FUNCTION 0X00.....	9
TABLE 3-2 : BUS : DEVICE : FUNCTION 0X01	9
TABLE 3-3 : BUS : DEVICE : FUNCTION 0X02.....	9
TABLE 3-4 : BUS : DEVICE : FUNCTION 0X03.....	9
TABLE 3-5 : PCI IDENTIFIERS	9
TABLE 3-6 : PCI BASE ADDRESS REGISTERS.....	10
TABLE 4-1 : LED STATUS.....	11
TABLE 5-1 : XMC CONNECTOR P15	12
TABLE 5-2 : SFP CONNECTOR.....	13

1 Product Description

The TXMC889 is a Switched Mezzanine Card (XMC) compatible module providing a four channel Gigabit Ethernet Small Form Factor Pluggable (SFP) interface.

The XMC-Connector P15 provides access to the Intel™ I350-AM4 quad port Gigabit Ethernet controller via an x4 PCIe link.

The TXMC889's SFP Cages accept various SFP transceiver modules. These four SFP hosts are connected to the Ethernet Controller's SerDes Interfaces.

The following transceiver modules have been successfully tested with the TXMC889:

- Intel XDACBL1M
(SFP+ Direct Attach Twinaxial Cable)
- Finisar FCBG110SD1C01
(SFP+ SFPwire Active Optical Cable)
- Intel E10GSFPSR
(SFP+ 1000BASE-SX)
- Finisar FTLX8574D3BCV
(SFP+ 1000BASE-SX)
- Intel E10GSFPLR
(SFP+ 1000BASE-LX)
- Finisar FTLX1475D3BCV
(SFP+ 1000BASE-LX)
- Finisar FTLF8519P3BTL
(SFP 1000BASE-SX)
- Finisar FTLF1318P3BTL
(SFP 1000BASE-LX)
- Finisar FCLF8522P2BTL
(SFP 1000BASE-T)

All compatible transceivers modules and replacements of the tested modules will also work properly with the TXMC889.

The controller is equipped with a 1 Mbit serial flash memory for Boot ROM and a 128 Kbit EEPROM storing configuration data. LEDs in the front panel indicate the different network activities.

For preconfigured variants of the hardware module containing transceiver modules, please contact TEWS.

The TXMC889-10R provides four Gigabit Ethernet Interfaces via front panel SFP connectors.

Software support:

- Software support for Intel™ I350 at www.intel.com
- For operating systems not supported by Intel™, please contact TEWS.

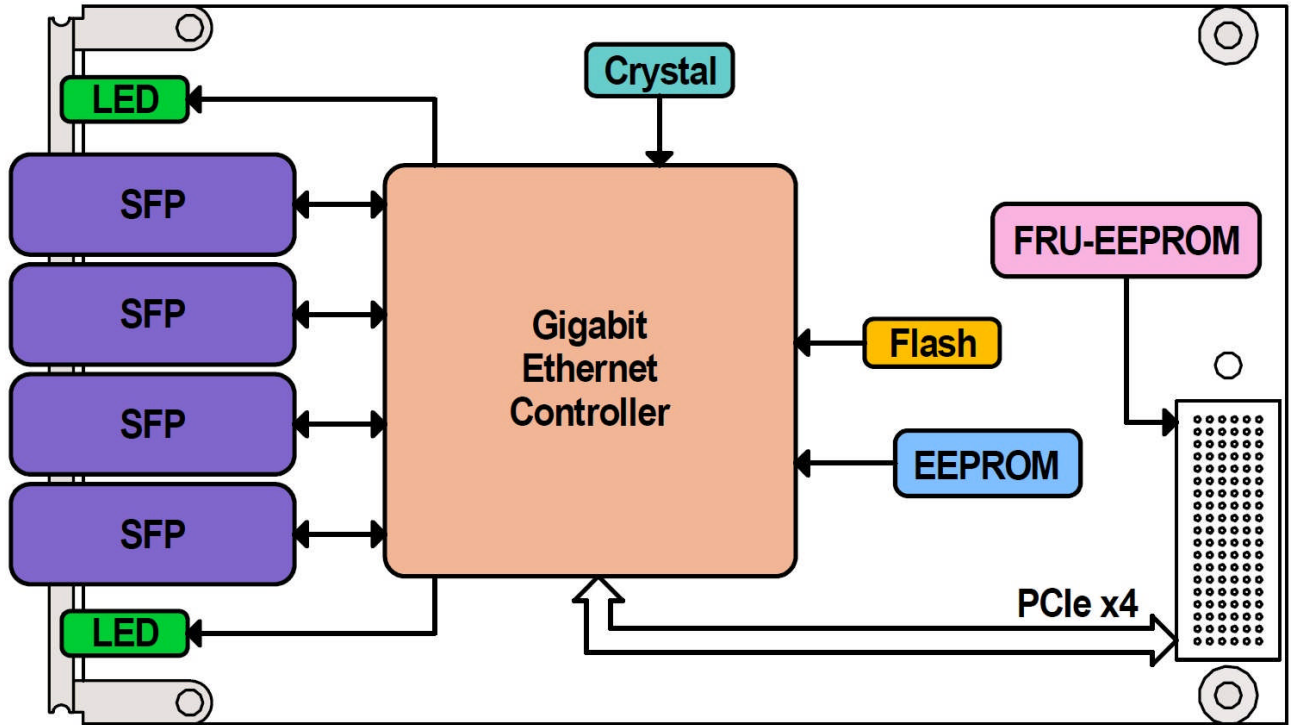

Figure 1-1 : Block Diagram

2 Technical Specification

XMC Interface	
Mechanical Interface	Switched Mezzanine Card (XMC) Interface conforming to ANSI/VITA 42.0-2016 Short single-width (124 mm x 74 mm)
Electrical Interface	PCI Express (Base Specification 2.1) up to x4 compliant interface conforming to ANSI/VITA 42.3-2006 (R2014) (XMC PCI Express Protocol Layer Standard)
On Board Devices	
Gigabit Ethernet Controller	I350-AM4 (Intel)
IPMI resource FRU Data EEPROM	M24C02 (STMicroelectronics)
I/O Interface	
Number of Channels	4
I/O Standards	Direct Attach Twinaxial Cable SFPwire Active Optical Cable 1000Base-SX 1000Base-LX 1000Base-T
I/O Connector	SFP (Amphenol U77-A461M-2081 and Molex 74441-0001 or compatible)
Physical Data	
Power Requirements	600mA typical @ VPWR = +12V DC 1400mA typical @ VPWR = +5V DC 1mA typical @ +3.3Vaux DC
Temperature Range	Operating -40°C to +85°C Storage -40°C to +85°C
MTBF	431000 h MTBF values shown are based on calculation according to MIL-HDBK-217F and MIL-HDBK-217F Notice 2; Environment: G _B 20°C. The MTBF calculation is based on component FIT rates provided by the component suppliers. If FIT rates are not available, MIL-HDBK-217F and MIL-HDBK-217F Notice 2 formulas are used for FIT rate calculation.
Humidity	5 – 95 % non-condensing
Weight	106 g

Table 2-1 : Technical Specification

3 PCI Interface

3.1 Multifunctional Device (Intel Corporation)

The Intel I350-AM4 Gigabit Ethernet Controller is represented by a multifunctional device on the PCI bus. The four different Ethernet Channels can be identified by the corresponding function of the device.

Ethernet Controller	
Vendor-ID	0x8086 (Intel Corporation)
Device-ID	0x1522 (I350 Gigabit Fiber Network Connection)

Table 3-1 : Bus : Device : Function 0x00

Ethernet Controller	
Vendor-ID	0x8086 (Intel Corporation)
Device-ID	0x1522 (I350 Gigabit Fiber Network Connection)

Table 3-2 : Bus : Device : Function 0x01

Ethernet Controller	
Vendor-ID	0x8086 (Intel Corporation)
Device-ID	0x1522 (I350 Gigabit Fiber Network Connection)

Table 3-3 : Bus : Device : Function 0x02

Ethernet Controller	
Vendor-ID	0x8086 (Intel Corporation)
Device-ID	0x1522 (I350 Gigabit Fiber Network Connection)

Table 3-4 : Bus : Device : Function 0x03

3.2 Identifiers

Vendor-ID	0x8086 (Intel Corporation)
Device-ID	0x1522 (I350 Gigabit Fiber Network Connection)
Class Code	0x0200 (Ethernet Controller)
Subsystem Vendor-ID	0xFFFF
Subsystem Device-ID	0x0000

Table 3-5 : PCI Identifiers

3.3 PCI Base Address Register Configuration

PCI Base Address Register (Offset in PCI Configuration Space)	PCI Space Mapping	Size (Byte)	Port Width (Bit)	Endian Mode	Description
0 (0x10)	MEM	256K	32	Little	Internal Registers
1 (0x14)	-	-	-	-	-
2 (0x18)	I/O	32	32	Little	Internal Registers
3 (0x1C)	MEM	16K	32	Little	MSI-X BAR

Table 3-6 : PCI Base Address Registers

4 LEDs

The TXMC889 front panel provides four Status LEDs for quick visual inspection and debugging. A marking is placed close to each LED, to indicate the Ethernet Port the LED corresponds to.

Each Ethernet Port has one LED indicator. See table below for more details:

LED Status	Description
OFF	No cable is connected or no link is established
ON	A link is established at the corresponding Ethernet Port
BLINKING	Indicates activity: The Ethernet Port transmits or receives data

Table 4-1 : LED Status

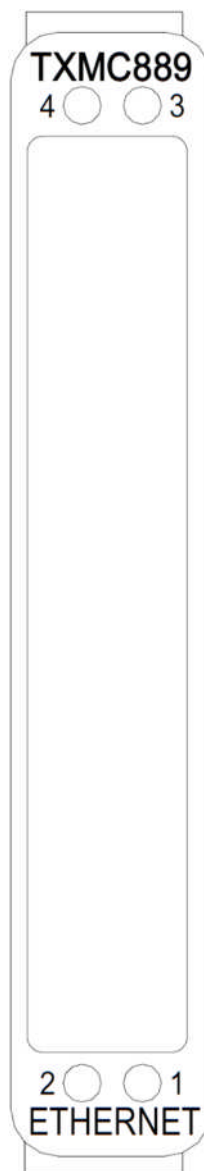

Figure 4-1 : TXMC889 Front Panel

5 Pin Assignment – I/O Connector

5.1 XMC Connector P15

	A	B	C	D	E	F
1	PET0p0	PET0n0	3.3V	PET0p1	PET0n1	VPWR
2	GND	GND	\overline{TRST}	GND	GND	\overline{PERST}
3	PET0p2	PET0n2	3.3V	PET0p3	PET0n3	VPWR
4	GND	GND	TCK	GND	GND	\overline{MRSTO}
5	PET0p4	PET0n4	3.3V	PET0p5	PET0n5	VPWR
6	GND	GND	TMS	GND	GND	+12V
7	PET0p6	PET0n6	3.3V	PET0p7	PET0n7	VPWR
8	GND	GND	TDI	GND	GND	-12V
9	Reserved	Reserved	Reserved	Reserved	Reserved	VPWR
10	GND	GND	TDO	GND	GND	GA0
11	PER0p0	PER0n0	\overline{MBIST}	PER0p1	PER0n1	VPWR
12	GND	GND	GA1	GND	GND	$\overline{MPRESENT}$
13	PER0p2	PER0n2	3.3V AUX	PER0p3	PER0n3	VPWR
14	GND	GND	GA2	GND	GND	MSDA
15	PER0p4	PER0n4	Reserved	PER0p5	PER0n5	VPWR
16	GND	GND	MVMRO	GND	GND	MSCL
17	PER0p6	PER0n6	Reserved	PER0p7	PER0n7	Reserved
18	GND	GND	Reserved	GND	GND	Reserved
19	REFCLK+0	REFCLK-0	Reserved	\overline{WAKE}	$\overline{ROOT0}$	Reserved

Table 5-1 : XMC Connector P15

5.2 SFP Connector

Pin	Signal
1	VeeT
2	Tx_Fault
3	Tx_Disable
4	SDA
5	SCL
6	Mod-ABS
7	RS0
8	Rx_LOS
9	RS1
10	VeeR
11	VeeR
12	RD-
13	RD+
14	VeeR
15	VccR
16	VccT
17	VeeT
18	TD+
19	TD-
20	VeeT

Table 5-2 : SFP Connector