

3U VPX™ board based on Intel® Xeon® E or 9th Generation Intel® Core™ i3 Processor

Key Features

TR E8x/msd-RCx is a 3U VPX™ module based on the Intel® Coffee Lake Refresh family to provide enhanced processing performance with optimized Size, Weight and Power (SWaP) characteristics.

- Option for workstation processor performance with enterprise-class graphics capabilities Intel® Xeon® E processor
- Alternatively a lower cost version is available using the 9th Generation Intel® Core™ i3 processor
- Error Correcting Code (ECC) memory for high operational reliability
- XMC site for local I/O expansion
- Local solid-state storage options
- Air-cooled and rugged conduction-cooled variants
- Rear plug compatible with the popular TR E5x/3sd-RCx family

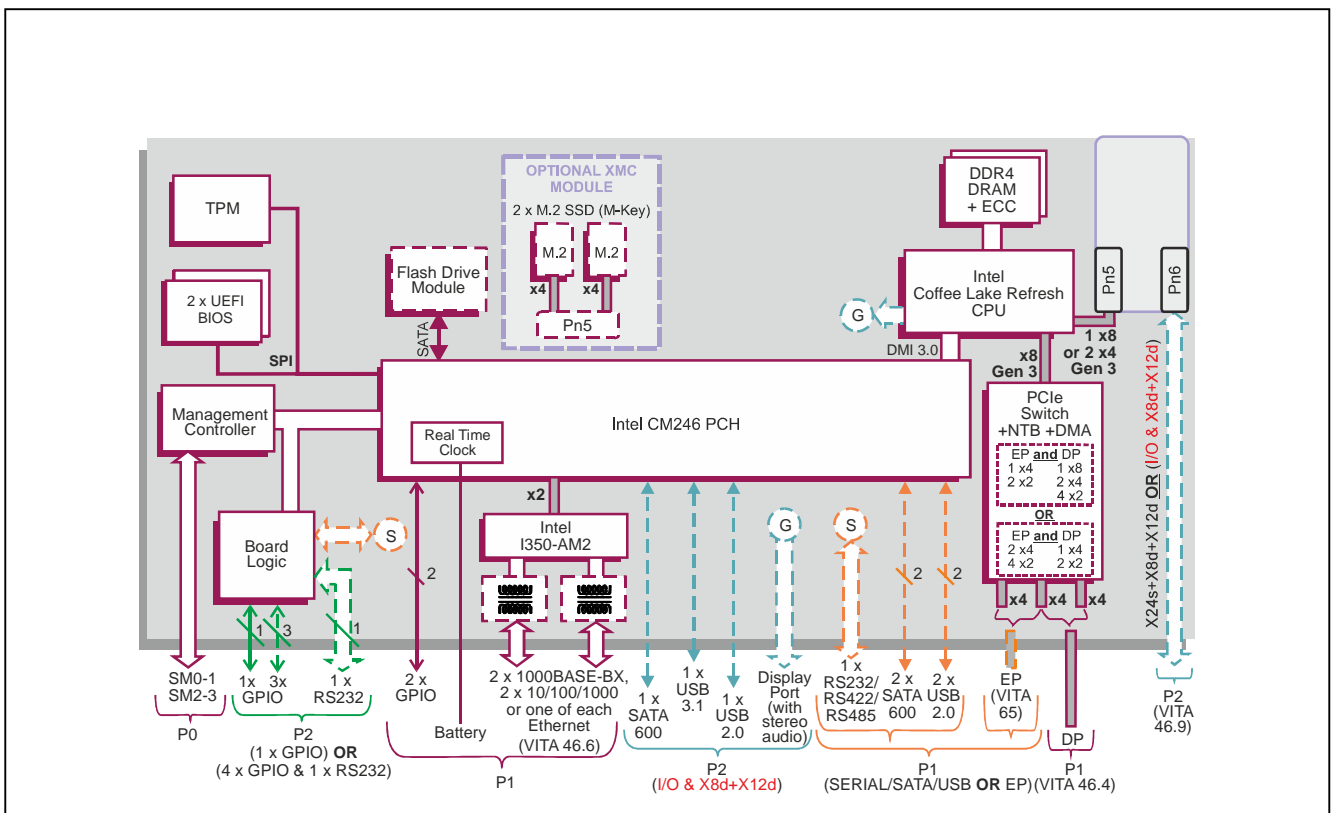

VPX Processor Board

- conduction-cooled 3U VPX-REDI™ board utilizing processors based on Intel® processor Coffee Lake Refresh
- compatible with several OpenVPX™ module profiles:
 - MOD3-PAY-2F2U-16.2.3-10
 - MOD3-PAY-2F1F2U-16.2.1-4
 - MOD3-PAY-1F2F2U-16.2.2-4
- air-cooled variants available:
 - see TR E8x/msd datasheet

Central Processor

- 6-core Intel® Xeon® processor E-2276ME:
 - 12 Mbytes SmartCache, up to 2.4 GHz (35W)
- 4-core 9th Generation Intel® Core™ i3-9100HL:
 - 6 Mbytes SmartCache, up to 1.6 GHz (25W)
- Intel® UHD Graphics
- range of performance/power factory build options
- utilizes the Intel® CM246 Platform Controller Hub

DRAM

- up to 32 Gbytes soldered DDR4 ECC DRAM:
 - single bit error correction
 - dual channel architecture
- accessible from processor or VPX™ fabric

XMC Site

- 1 x XMC site, in a single VPX slot (VITA 42.0):
 - 1 x8 or 2 x4 PCI Express® (PCIe®)
 - PCIe Gen 1, Gen 2 and Gen 3
- XMC connector type (build option):
 - up to Gen 2, VITA 42 XMC (black color)
 - up to Gen 3, VITA 61 XMC 2.0 (white color)
- XMC VPWR +5V or +12V (build option)

VPX P2 I/O Option

- P2 factory build options, option 1 (full rear XMC I/O) or option 2 (reduced XMC I/O plus additional P2 I/O)
- VPX P2 build option 1 supports the following:
 - full rear XMC I/O, providing X24s+X8d+X12d
 - DisplayPort® is not available (board is headless)
- VPX P2 build option 2 supports the following:
 - reduced rear XMC I/O, providing X8d+X12d
 - 1 x USB 2.0 port and 1 x USB 3.1 (Gen 1) port
 - 1 x SATA600 interface
 - 1 x DisplayPort with audio interface
- VITA 46.9 compliant XMC I/O pin-out

Serial Ports

- 1 x RS232/422/485 port accessed via P1 (replaces VPX Expansion Plane PCI Express interface)
- option for 1 x RS232/422/485 port accessed via P2:
- 16550 compatible UARTs

Graphics/Audio Interface

- independent graphics/audio interface:
 - DisplayPort v1.2 interface, supporting audio and video, via P2 (P2 build option 2)
 - up to 3840 x 2160 @ 60Hz, driver dependent
- support for Microsoft® DirectX 12
- support for OpenGL 4.x under Windows® and Linux® and support for OpenCL 2.0

Other Peripheral Interfaces

- PC RTC, long duration timer, watchdog timer
- up to 4 x USB ports via the rear:
 - option for 2 x USB 2.0 ports via P1 (replaces VPX Expansion Plane PCI Express interface)
 - option for 1 x USB 2.0 and 1 x USB 3.1 (Gen 1) ports via P2 (build option 2)
- 2 x GPIO signals via P1
- option for up to 4 x GPIO signals via P2 (1 or 4)

Mass Storage Interfaces

- 2 x SATA600 interfaces via P1 (replaces VPX Expansion Plane PCI Express interface)
- 1 x SATA600 via P2 (build option 2)
- 1 x SATA600: optional on-board Flash Drive Module
- optional XMC module, 2 x M.2 SSD sites supports:
 - 2242 format module
 - x4 PCIe interface (M-key) per site
 - NVMe Express® (NVMe™) logical device interface

VPX Control Plane, Ethernet

- configurable Control Plane (VITA 46.6)
- P1 factory build option for 2 x 1000 Mbps IEEE802.3z SerDes (1000BASE-BX) ports:
 - with software switchable option for 1 x 10/100/1000BASE-T Ethernet port (with magnetics) plus 1 x 1000BASE-BX port
- alternative P1 factory build option for 2 x 10/100/1000BASE-T Ethernet ports:
 - both ports with magnetics
- supports IEEE 1588 Precision Time Protocol
- implemented by Intel® Ethernet Controller I350-AM2 via x2 PCI Express Gen 2 port

VPX Data/Expansion Plane, PCI Express

- configurable PCI Express (PCIe) VPX Data Plane fabric interface (VITA 46.4)
- P1 build option for either:
 - P1 I/O: 1 x Serial, 1 x SATA600, 1 x SATA300 and 2 x USB 2.0 ports
 - or user configurable PCIe Expansion Plane interface (VITA65)
- PCIe Expansion Plane interface options:
 - x8 Data Plane (1 x8 or 2 x4 or 4 x2) with x4 Expansion Plane (1 x4 or 2 x2)
 - x4 Data Plane (1 x4 or 2 x2) with x8 Expansion Plane (2 x4 or 4 x2 or 1 x4 & 2 x2)
- PCIe interfaces support Gen 1, Gen 2 and Gen 3
- PCIe switch supports two non-transparent ports for multi-processing configurations
- 4 channel DMA engine for fast data block moves
- ports can be configured by the VPX Switch Configuration Tool, see separate datasheet
- support for PCIe backplane common clock options

System Management

- IPMI via SMO-3, accessing:
 - voltages monitor, CPU temperature monitor and board temperature monitor
- Baseboard Management Controller (BMC)
- support for Serial Over LAN
- option for VITA 46.11 compatible Tier 1 Chassis Manager

Optional Built-In Test (BIT) Support

- Power-on BIT, Initiated BIT, Continuous BIT

Board Security Features

- Trusted Platform Module (TPM 2.0)
- option for Sanitization Utility Software Package
- option for proprietary board-level security features

Software Support

- supports Linux® and Windows®
- for other operating systems contact Concurrent Technologies for further information, e.g. VxWorks®
- options available for enhanced PCIe drivers

Firmware Support

- dual 32 Mbyte BIOS SPI Flash EPROMs
- UEFI boot firmware (BIOS):
 - UEFI 2.7 support
 - implements Secure Boot
- implements Intel® Boot Guard
- optional Fast Boot solution using the Intel® Firmware Support Package (FSP)
- LAN boot firmware included

Safety

- PCB (PWB) manufactured with flammability rating of UL94V-0

Electrical Specification (Estimated)

- typical current figure for E-2276ME (2.4 GHz, 35W) processor with 16 Gbytes DRAM:
 - +5V @ 2.5A; +3.3V @ 3.0A; +3.3V AUX @ 0.3A
- +12V AUX and -12V AUX routed to XMC site

Environmental Specification

- conduction-cooled (VITA 48.2)
- operating temperature at card edge (selected CPU):
 - VITA 47 Class CC4, -40°C to +85°C
- non-operating temperature:
 - VITA 47 Class C4, -55°C to +105°C
- operating altitude:
 - VITA 47 -1,500 to 60,000 feet
 - (-457 to 18,288 meters)
- 5% to 95% Relative Humidity, non-condensing
- option for VPX non-rugged air-cooled version:
 - see TR E8x/msd datasheet

Mechanical Specification

- 3U VPX form-factor (VITA 46.0, VITA 48.2):
 - 3.9 inches x 6.3 inches (100mm x 160mm)
- slot widths (VITA 48.0):
 - 1.0 inch and 0.8 inches VPX-REDI Type 2, RCT-Series
 - 1.0 inch and 0.85 inches VPX-REDI Type 1, RCS-Series, Type 1 Two Level Maintenance (VITA 48.2)
 - 1.0 inch VPX-REDI Type 1, RCR-Series Type 1 Extended Covers Two Level Maintenance (VITA 48.2)
- connectors to VITA 46.0 for P0, P1 and P2
- captive screws available to secure front handles
- operating mechanical:
 - shock - VITA 47 Class OS2, 40g
 - random vibration - VITA 47 Class V3, 0.1g²/Hz

Optional VPX Fabric Switch

- board is compatible with FR 34x/x06-RCx VPX Switch